

深圳市凯杰鑫科技有限公司

Shenzhen KayJX Technology Co., Limited

承认书

Acknowledgment

Customers 客户:

Battery Model 电池型号: 18650-1S-1P- 3.2V /1500mAh

Cell Type 电芯类型: LiFePO4

Cell Model 电芯型号: 18650/1500mAh

Date of Issue 制作日期: 2018.12.18

KayJX Signed 凯杰鑫签署		Signature by customer 客户签署	
Made 拟定		Customer Conformation 客户 确认:	
Verification 审核:			
Permission 批准:			

Address: Room 206, MingJun Business Center, Langrong RD, Dalang Community, Dalang ST, Longhua New District, Shenzhen

地址: 深圳市龙华新区大浪浪荣路明君商务中心 206

Telephone / Fax 电话/传真: 0755-21038782

History of revision
版本更改历史记录

Version 版本号	Date 更改时间	Event 更改内容
A0	2018-12-18	For the first time to issue 首次发行

Contents 目录

1. Scope 适用范围	4
2. Adopted Standard 引用标准.....	4
3. Electrical Characteristics 电气特性	4
4. Battery Configuration 电池组成	5
5. Battery Performances Test Criterion 电池性能测试规范.....	5
5.1 Appearance 外观	5
5.2 Measurement Apparatus 测试设备	5
5.3 Reliability Test 可靠性测试	6
6. Shipment 运输	6
7. Storage 贮存	6
8. Package and Marking 包装与标志	6
8.1 Package 包装	6
8.2 Marking 标志	6
9. Protection Circuit 保护电路.....	6
9.1 PCM BOM.....	7
10. Outline Drawing 外形图纸	7
11. Appendix 附录	7
11.1 Instructions and Safety Requirement 使用说明和安全规程.....	8
11.1.1 Recommending Usage 推荐使用事项	8
11.1.2 Hazard Warning 危险警告	8
11.1.3 Warning 警告.....	9
11.1.4 Cautions 注意事项	10
11.2 Quality Evaluation Programme 质量评定	11
11.3 Environment Protection 环保要求	11
11.4 Others 其他事项	11

1. Scope 适用范围

This description defines the general requirements for the battery's rating parameter, electrical requirement, safety requirement, environmental compatibility, test and judgment, usage instructions, safety regulation, quality evaluation and packaging, marking, storage, shipment and handling, which cellular phone battery with CJ18650 rechargeable battery cell, adapted for 18650 Digital products.

本规格书描述电池之标称参数、电气特性、安全性能、环境适应性及其实验和判定、使用说明和安全规程、质量评定及包装、标志、贮存、运输等。适用于采用 18650 电芯制成的配套电池。

2. Adopted Standard 引用标准

GB/T18287-2014, The People's Republic of China General Regulations of Lithium Ion Battery for Cellular Phone.

GB/T 18287-2014 中华人民共和国蜂窝电话用锂离子电池总规范。

3. Electrical Characteristics 电气特性

No 序号	Item 内容	Parameter 参数		Remark 备注
1	Rating Voltage 标称电压	3.2V		
2	Capacity 标称容量	1500mAh		0.2C discharge after full charge。 完全充电后用 0.2C 放电至截止电压的容量。
3	Charge Voltage 充电电压	3.65±0.03V		
4	Impedance 内阻	150 mΩ (Max 成品)		
5	Charging Mode 充电方式	C.C/C.V. 恒流/恒压方式		Constant Current /Constant Voltage 恒流/恒压 视电池电压转换
6	Charging Method 充电方法	Standard Charging 标准充电		Charging Current 0.5A 充电电流: 0.5A
		Fast Charging 快速充电		Charging Current 1A 充电电流: 1A
7	Charging Time 充电时间	Standard Charging 标准充电	About 3Hours	
		Fast Charging 快速充电	About 1.5Hours	
8	End of Discharge Voltage 放电截止电压	2.5V		
9	Over charge Voltage 过充电保护电压	3.65±0.025V		
10	Over charge recovery voltage 过充恢复电压	3.65±0.050V		
11	Overcharge delay time 过充延时时间	700~1300mS		
12	Over Discharge Cut Off Voltage	2.5±0.063v		

	过放电保护电压		
13	Over shoot recovery voltage 过放恢复电压	3.0±0.75V	
14	Over shoot delay time 过放延时时间	10~30mS	
15	Over Current Protection 过流保护	8~11A	
16	Over Current Delay Time 过流延时时间	10~30mS	
17	The normal working current 正常工作电流	≤3A	
18	Short Circuit 输出短路保护	Recover after removing the short circuit load 保护后撤销短路负载恢复	
19	Short circuit protection delay time 短路保护延时时间	200~500 μ S	
20	Operating Temperature 工作温度	Charging 充电	0~45
		Discharging 放电	-10~60℃
21	Storage Temperature 贮存温度	-5℃-35℃ Recommend 推荐 (25±5℃)	Storage capacity should be 40%~50% full charge capacity 贮存时应充电至容量的 40%~50%
22	ESD Test 静电测试	±4KV	

4. Battery Configuration 电池组成

No. 编号	Item 项目	Type 类型	Qty 数量
1	Cell 电芯	18650/3.2V/1500mAh	1PCS
2	PCM 保护板	R5478N184CJ +8205*2	1PCS
3	电子线	JST-PHR-2P, 正向插头, 1007/22AWG, 红、黑线长 100mm	1PCS

5. Battery Performances Test Criterion 电池性能测试规范

5.1 Appearance 外观

There shall be no such defect as scratch, flaw, crack, rust, leakage, which may adversely affect commercial value of battery.

电池外表面清洁，无电解液泄漏，无明显的划痕及机械损伤，无变形，无影响电池价值的其它外观缺陷。

5.2 Measurement Apparatus 测试设备

(1) Dimension Measuring Instrument 尺寸测量设备

The dimension measurement shall be implemented by instruments with equal or more precision scale of 0.01mm.

测量尺寸的仪器的精度应不小于 0.01mm。

(2) Voltmeter 电压表

Standard class specified in the national standard or more sensitive class having inner impedance not less

than 10 K Ω /V.

国家标准或更灵敏等级，内阻不小于 10 K Ω /V。

(3) Ammeter 电流表

Standard class specified in the national standard or more sensitive class. Total external resistance including ammeter and wire is less than 0.01 Ω .

国家标准或更灵敏等级，外部总内阻包括电流表和导线应小于 0.01 Ω 。

(4) Impedance Meter 内阻测试仪

Impedance shall be measured by a sinusoidal alternating current method(AC 1kHz LCR meter).

内阻测试仪测试方法为交流阻抗法(AC 1kHz LCR)。

5.3 Batteries Reliability Test 电芯可靠性测试

Refer to the attachment

请参考附件

6. Shipment 运输

The battery should be packed in cartons under the condition of half capacity 20-50% for shipment. The violent vibration, Impact or squeezing should be avoided in the transport process; neither is exposed in the sunlight nor rain. The batteries shall be shipped by normal transportation such as by road, by train, by ocean or by air.

电池应在半荷电状态 20-50% 充电状态下包装成箱进行运输，在运输过程中应防止剧烈振动、冲击或挤压，防止日晒雨淋，应适用汽车、火车、轮船、飞机等普通运输工具。

7. Storage 贮存

The battery storage shall be in the clean and dry ventilation room at the temperature of $-5\sim 35^{\circ}\text{C}$ and shall keep out of fire or heat and avoid touching corrosion elements. The batteries shall be charged every 6 months during storage. Both the stored cells in the process of the battery and the batteries in delivery shall be “first come, first use”. The battery storage period is 6 months when into the warehouse. Batteries expired must have a thorough check. Only the applicable batteries can be dispatched to the purchaser; the inapplicable ones shall be rechecked, if it remains, the purchaser shall have the right to dispose bad ones.

电池应贮存在环境温度 $-5\sim 35^{\circ}\text{C}$ 的清洁、干燥通风的室内，应避免与蚀性物质接触，应远离火源及热源。电池贮存过程中每六个月充电一次。电池的加工过程中使用库存电芯和电池交货出库时，均应该遵循“先进先出”的原则；电池从入库之日起，保存期限为 6 个月，超过贮存期限的产品必须重新进行逐批检查，合格后才能交付订货方，逐批检查不合格的按再提交检查的批处理，若仍然不合格，将由订货方决定处置。

8. Package and Marking 包装与标志

8.1 Package 包装

According to the attached.

包装箱外应标明产品名称、型号、数量、毛重、制造厂商及联络地址、出厂日期。

8.2 Marking 标志

Every battery shall have the following Chinese characters: Product、type、rating voltage 3.6V、rating capacity、contacts plus or minus and warnings、produce date、lot No.、manufacturer、(or the marks of the above characters)。

每个电池上应有下列中文标志：产品名称、型号、标称电压、标称容量、正负极性商标和警示说明、以及制造日期、批号、制造厂名、（或包括以上数据的串号）。

9. Protection Circuit 保护电路

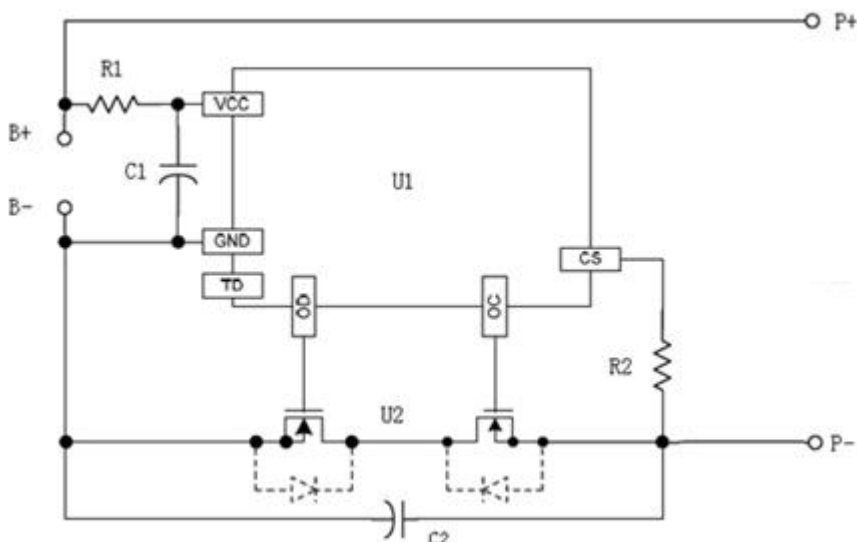

9.1 PCM BOM

器件编号	描述	规格	尺寸/封装	数量	环境	备注
U1	贴片保护 IC Protection IC	R5478N184CJ	SOT-23-6	1	RoHS	ROHS
U2	MOS	8205A	TSSOP-8	2		ROHS
R1	贴片电阻	330R	0603	1		ROHS
R2	贴片电阻	1K	0603	1		ROHS
C1	贴片电容	0.1uF	0603	1		ROHS

10. Outline Drawing 外形图纸

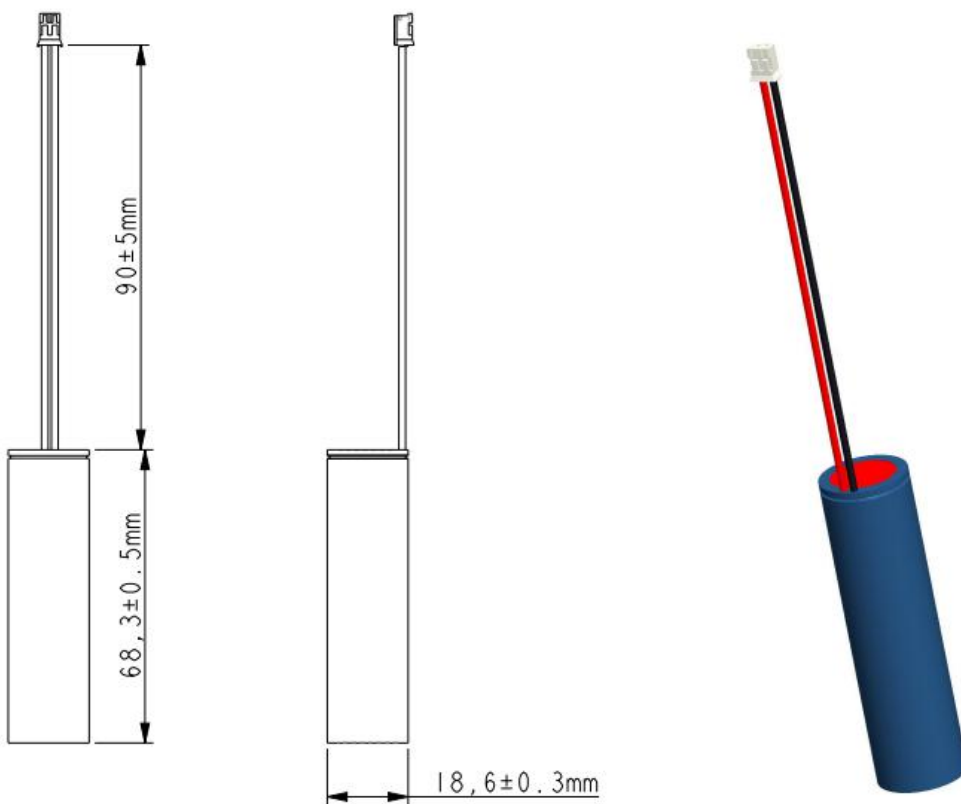

10.1 The label 标签

18650 lithium batteries

Model: LiFePO4

Nominal voltage: 3.2V

Capacity : 1500mAh

11. Appendix 附录

11.1 Instructions and Safety Requirement 使用说明和安全规程

11.1.1 Recommending Usage 推荐使用事项

- 1 Please read the battery instructions and the label on its surface before use.**
使用电池前，请仔细阅读使用说明书和电池表面标识。
- 2 Use the battery indoors under normal condition, temperature: $(20\pm 5)^{\circ}\text{C}$, absolute humidity: $65\pm 20\%$.**
请在正常的室内环境中使用电池，温度： $(20\pm 5)^{\circ}\text{C}$ ，相对湿度： $65\pm 20\%$ 。
- 3 When in use, the battery shall be kept out of heat、high voltage and avoided children's touching. Do not drop the battery.**
在使用过程中，应远离热源、高压，避免儿童玩弄电池，切勿摔打电池。
- 4 Use the compatible charger. Do not put the battery into the charger over 24hours.**
本电池只能使用配套充电器充电，不要将电池放在充电器超过 24 小时。
- 5 Do not touch contacts together. Do not demolish or assembly the battery by yourself. Do not put the battery in the damp place to avoid danger.**
切勿将电池正负极短路，切勿自己拆装电池，也勿让电池放在受潮处，以免发生危险。
- 6 When the battery was stored for a long period, put it well in its half capacity. Do not wrap it with conduct material to avoid the damage caused by the direct contact between the metal and battery. Keep the battery in day places.**
长期不用时，请将电池储存完好，让电池处于半荷电状态。请用不导电材料包裹电池，以避免金属直接接触电池，造成电池损坏，将电池保存阴凉干燥处。
- 7 Well disposed the disused battery. Do not put it into fire or water.**
废弃电池请安全妥当处理，不要投入火中或水中。

11.1.2 Hazard Warning 危险警告

- 1 Forbid Disassemble Batteries 禁止拆装电池**
The battery has protective component and circuit internally to avoid danger. Mishandling such as improper disassembly will destroy its protective function and make it heat, smoke, distort or burning.
电池内部具有保护机构和保护电路可以避免发生危险。不合适的拆装会损坏保护功能，将会造成让电池发热、冒烟、变形或燃烧。
- 2 Forbid Short-circuit Batteries 禁止让电池短路**
Do not touch the plus and minus contacts with metals. Do not put the battery with metal element together in either storage or movement. If the battery is short-circuit, it carries magnified current, which will cause damage and make the battery heat, smoke, distort or burning.
不要将电池的正负极用金属连接，也不要将电池与金属片放在一起存储和移动。如果电池被短路，将会有超大电流流过，将会损坏电池，造成电池发热、冒烟、变形或燃烧。
- 3 Forbid heat and burn the battery 严禁加热和焚烧电池**
If heating or burning the battery, it will caused the isolated element in the battery dissolved, protection function stopped or the electrode burning, over heated, which will make the battery heat, smoke, distort or burning.
加热和焚烧电池将会造成电池隔离物的溶化、安全功能丧失或电解质燃烧，过热就会使电池发热、冒烟、变形或燃烧。
- 4 To avoid use the battery near the heat 避免在热源附近使用电池**
Do not use the battery near the fire and stove, or over 80°C , and over heating will cause the battery internal short-circuit and make it heat, smoke, distort or burning.
不要在火源、烤炉附近或超过 80°C 的环境中使用电池，过热将会导致电池内部短路，使电池发热、冒烟、变形或燃烧。
- 5 Forbid bathing the battery 禁止弄湿电池**

Do not dampen the battery, or even immerse it in the water, which will cause internal protection circuit and its function lost or abnormal chemical reactions, which will lead to heating, smoking, distortion or burning.

不要弄湿电池，更不能将电池投入水中，否则会造成电池内部保护电路和功能丧失及发生不正常的化学反应，电池有可能发热、冒烟、变形或燃烧。

6 Avoid charging near fire or in the sunlight 避免在火源附近或阳光直射下充电

Otherwise, it will cause internal protection circuit and its function lost or abnormal chemical reactions, which will lead to heating, smoking, distortion or burning.

否则会造成电池内部保护电路和功能丧失和发生不正常的化学反应，电池有可能发热、冒烟、变形或燃烧。

7 Danger in using non-indicated chargers in 使用非专用充电器给电池充电，会发生危险

Charging in abnormal condition, the battery will cause internal protection circuit and its function lost or abnormal chemical reactions, which will lead to heating, smoking, distortion or burning.

在非正常的条件下充电会造成电池内部保护电路功能丧失和发生不正常的化学反应，电池有可能发热、冒烟、变形或燃烧。

8 Forbid Damage Battery 禁止破坏电池

Do not allow damage the battery with the metals gouged, forged or dropped etc. , otherwise, it will cause over-heated, distort, smoke or burning, even in danger.

禁止用金属凿入电池、锤打或摔打电池或其他方法破坏电池，否则会造成电池发热、冒烟、变形或燃烧，甚至会发生危险。

9 Forbid directly welding on the battery 禁止在电池主体上直接焊

Over-heated will cause the isolated element dissolved in the battery and losing protective function its cycle life, even will cause over-heated, distort, smoke or burning.

过热将会造成电池隔离物的溶化、安全保护功能丧失，使电池发热、冒烟、变形或燃烧。

10 Forbid directly charging on the power socket or car kit cigarette 严禁将电池直接在电源插座上或车载点烟器上充电

High voltage and amplified current will damage the battery and reduce its cycle life, even will cause over-heated, distort, smoke or burning.

高压、大电流将会过电池而使其损坏，或使电池发热、冒烟、变形或燃烧。

11 Do not use this battery for other equipment 不可将电池用于其他设备

Inappropriate usage will damage the battery and reduce its cycle life, even will cause over-heated, distort, smoke or burning.

不恰当使用会损坏电池的性能、降低寿命，甚至会使电池发热、冒烟、变形或燃烧。

12 Do not touch the leak-out battery 不要直接接触及漏液电池

The leak-out electrolyte will cause the skin uncomfortable. If it drops into eyes, do not rob the eyes but wash in time, and go to hospital for treatment.

渗漏的电解液会造成皮肤不适，万一电解液进入眼睛，尽快用清水冲洗，不可揉眼，并迅速送医院处理。

11.1.3 Warning 警告

1 This battery cannot mix with disposable or twice- recycled batteries in use. Otherwise, for its abnormal charge and discharge, it will cause over-heated, distort, smoke or burning.

电池不可与其它类型的一次或二次电池混用，否则因为不正常的充、放电造成电池发热、冒烟、变形或燃烧。

2 Keep the battery out of children's reach and prevent them biting or swallowing the battery.

将电池远离孩童不能得到的地方，以避免孩童噬咬或吞咽电池，如果吞咽了电池，应迅速送医院处理。

3 Do not insert the battery onto the charger for a long time If charging beyond the normal time, the battery is still in the charger, please stop charging. The abnormal charging will cause battery over-heated, distort, smoke or burning.

如果超过正常充电时间很长时间充电器仍在充电，应停止充电，不正常的充电有可能会使电池发热、冒烟变形或燃烧。

- 4 Do not put into microwave stove or any other pressure apparatus. Take the battery away from the cellular phone or the charger if it is instant heated or leak-out (or odors) and dispose it. The bad battery will causes over-heated, smoke or burning.

不可置于微波炉或其他压力容器中,瞬间加热或结构漏液(或有异味),应让电池离开手机或充电器并弃用。使用不正常的电池会发热、冒烟、变形或燃烧。

11.1.4 Cautions 注意事项

1 Notice 注意

The battery shall be prevented to be exposed in effulgence so as not to cause over-heated, distort, smoke and weaken its performance and cycle life.

避免在强光曝晒环境下使用电池,以免发热、变形、冒烟.至少避免电池性能下降、降低寿命。

2 Electricity Static-free 防静电

There is a protective circuit inside the battery to prevent contingency. Do not use the battery in the Electricity static circumstances, (above 1000V), for it is easily destroyed the circuit board so that the battery doses not work and causes over-heated, distort, smoke or burning.

电池中装有保护电路以避免各种意外情况发生。不要在产生静电的场所使用电池,因为静电(1000V以上)容易损坏保护板,而导致电池工作不正常,发热、变形、冒烟或起火燃烧。

3 Discharging Temperature Range 充电温度范围

Recommended discharging temperature range is 0-40°C, beyond which it will result in decadence of the battery performance and shortness of its life.

推荐的充电温度范围是 0-40°C。在超出此范围的环境中充电会造成电池性能下降、减少寿命。

- 4 **Read carefully the manual before use or whenever in need.** 在使用电池之前,请仔细阅读使用手册并经常在需要时阅读。

5 Charging Method 充电方式

Use the special chargers in the recommended charging method to charge the battery.

请使用专用充电器和推荐的充电方式,在推荐的环境条件下给电池充电。

6 First Usage 第一次使用

When you use the battery for its first time, do not put it into the cellular phone or any other equipment once you find it in unusual conditions such as unclear or odors. The battery should be returned to the vendor.

在第一次使用电池时,若发现电池不整洁或有异味等不正常现象,不可继续将电池用于手机或其他它设备,应将电池返回销售商。

7 Children Use 儿童使用

When Children use the battery, they should be under their parents' instructions and superintend in use.

儿童使用电池前,应受父母指导,并在使用中受监督是否正确。

8 Avoid Children's Touch 避免孩童接触电池

Battery should keep out of the place where children in reach. Prevent children taking the battery out of the charger or the cellular phone to play.

电池应放在孩童不易拿到的位置,应避免孩童将电池从充电器或手机中取出、玩弄。

- 9 To avoid the leak-out liquid be exposed to the skin or clothes. If touched, please wash by clean water so as not to cause the skin uncomfortable

注意避免电池漏液接触皮肤或衣物,若已接触请用清水冲洗,以免造成皮肤不适。

10 Consultation 咨询

When you buy the battery, please note how to contact with the vendors, so that you may get intouch with vendors for consultation whenever in need.

购买电池时,请注意销售商联络方法,以便需要时及进与销售商取得联系,得到咨询。

11 Guarantee period 保用期

Guarantee is one year since it is out of the factory. Life time:2000 cycles。Any damage by incorrect use and not quality problem, even in its guarantee period, free service won't be provided by the manufacture.

保用期是自出厂之日起一年，寿命为：充放电循环 2000 次。但是属于使用不当而非质量问题，即使在保用期内，生产厂家也不会无偿更换新电池。

12 Safety Usage Guarantee 安全使用保障

If the battery is used on other instruments, please contact with your manufacturer for how to get the best performance, at least consult its maximum current, fast charge and special application.

如果将电池用于其他设备，请与供应商讨保护功能的完善性。至少应该咨询电池的大电流、快速充电、特殊应用的问题。

11.2 Quality Evaluation Programme 质量评定

Quality evaluation composes of authoritative check and quality consistence check. Authoritative check is carried out on design decision, emended design and production decision. It should be confirmed by both Purchaser and Vendor on sampling proposal, check project, sequence and judgment etc., which in principle, should be all included. Quality consistence check should be divided into lot by lot check-up and periodical check-up, as to test the quality steadiness during the products in production (refer to GB2828—1987 standard). The detailed check-ups compose of appearance, internal resistance, rating capacity or 1C_{5A} discharging capacity etc.

质量检验分为鉴定检验和质量一致性检验。鉴定检验一般在设计定型、更改设计和生产定型时进行，抽样方案、检验项目、顺序以及判定规则等事宜由供需双方协商确定。原则上应包括以上各项性能试验。质量一致性检验分为逐批检查和周期检查，用以判定产品生产过程中能否合格保证产品质量的持续稳定。可以参照 GB2828—1987，标准执行。具体检查的检验项目应包括外观、内阻、额定容量或 1C_{5A} 放电容量等。

11.3 Environment Protection 环保要求

This product accord with ROHS requirement.

此产品符合 ROHS 环保要求。

11.4 Others 其他事项

All the above are the agreed the battery descriptions and test regulation between Purchaser and Vendor. It can be carried out if there is no any new written agreement or modification notice occurred.

以上述，可以作为供需双方对于电池产品性能和检验规则的约定框架。如果没有新的书面约定或更改通知，即可按此执行。