

GN 702 Stop locks with 4 indexing positions (90°)

Zinc alloy



- 1
- 2
- 3
- 4
- 5
- 6
- 7
- 8
- 9
- 10
- 11
- 12
- 13
- 14
- 15
- 16
- 17
- 18

LEVER BODY

Die cast zinc alloy, epoxy resin coating.

COLOUR

RAL 9005 (SW) black or RAL 3000 (RS) red, matte finish.

BASE FLANGE

Die-cast zinc alloy, epoxy resing coating, black colour, matte finish, with two holes for clamping by means of countersunk head screws.

CLAMPING ELEMENT

Zinc-plated steel.

NUT

Zinc-plated steel.

STANDARD EXECUTIONS

- **GN 702-A:** base flanges with two holes for clamping by means of countersunk head screws.
- **GN 702-B:** machine element with threaded hole.
- **GN 702-C:** machine element with threaded ring.

FEATURES AND APPLICATIONS

GN 702 locks are suitable for clamping, by means of the lever rotation, drawers or doors in applications subject to strong vibrations. Locking position of the lever every 90°.

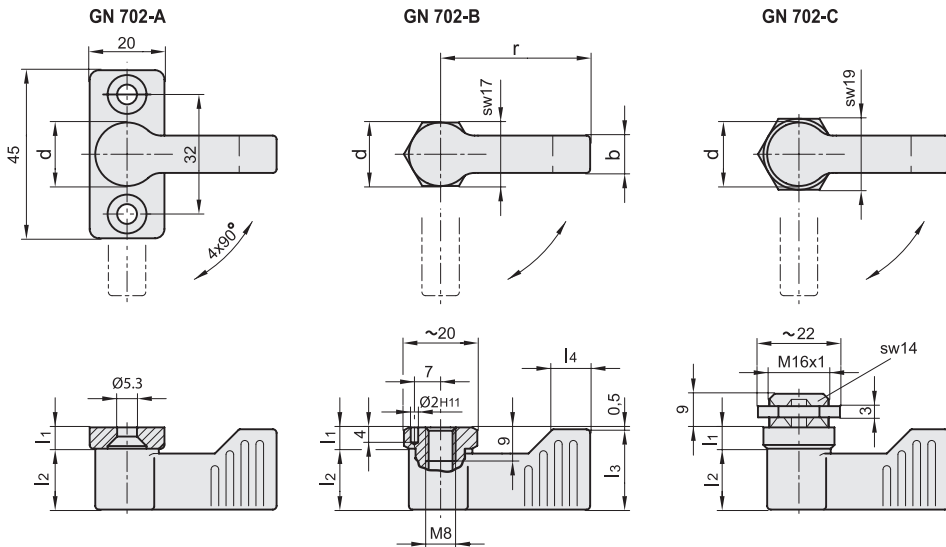

Code	Description	d	r	b	l1	l2	l3 min	l4	⊙
GN.30754	GN 702-17-40-A-SW	17	40	10	5.5	16.5	21.5	11	80
GN.30753	GN 702-17-40-A-RS	17	40	10	5.5	16.5	21.5	11	80
GN.30764	GN 702-17-55-A-SW	17	55	10	5.5	16.5	21.5	11	80
GN.30763	GN 702-17-55-A-RS	17	55	10	5.5	16.5	21.5	11	80
GN.30758	GN 702-17-40-B-SW	17	40	10	5.5	16.5	21.5	11	57
GN.30757	GN 702-17-40-B-RS	17	40	10	5.5	16.5	21.5	11	57
GN.30768	GN 702-17-55-B-SW	17	55	10	5.5	16.5	21.5	11	57
GN.30767	GN 702-17-55-B-RS	17	55	10	5.5	16.5	21.5	11	57
GN.30760	GN 702-17-40-C-SW	17	40	10	5.5	16.5	21.5	11	69
GN.30759	GN 702-17-40-C-RS	17	40	10	5.5	16.5	21.5	11	69
GN.30770	GN 702-17-55-C-SW	17	55	10	5.5	16.5	21.5	11	69
GN.30769	GN 702-17-55-C-RS	17	55	10	5.5	16.5	21.5	11	69

Latches

1418