



Model Number

NBN3-F31-E8-K

Features

- Direct mounting on standard actuators
- Compact and stable housing
- Fixed setting
- Satisfies machinery directive

Connection

E8-K

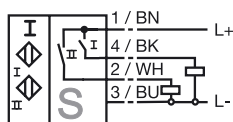

Accessories

BT65A

Activator for F31 series

BT65X

Activator for F31 series

BT115A

Activator for F31 series

BT115X

Activator for F31 series

BT65B

Activator for F31 series

BT115B

Activator for F31 series

Dimensions

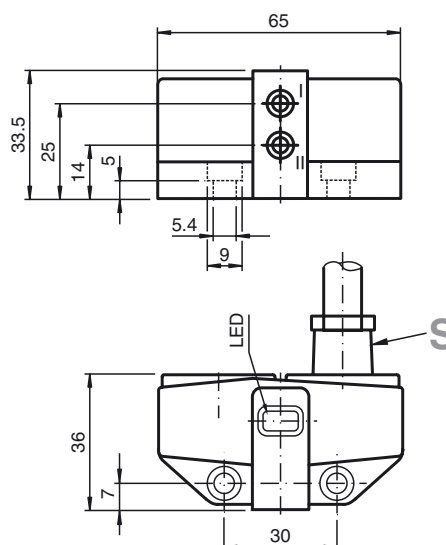

Technical Data

General specifications

Switching element function	PNP	Dual NO
Rated operating distance	s_n	3 mm
Installation		flush mountable
Output polarity		DC
Assured operating distance	s_a	0 ... 2.43 mm
Reduction factor r_{AI}		0.5
Reduction factor r_{Cu}		0.4
Reduction factor r_{304}		1
Reduction factor r_{S137}		1.2

Nominal ratings

Operating voltage	U_B	10 ... 30 V DC
Switching frequency	f	0 ... 500 Hz
Hysteresis	H	typ. 5 %
Reverse polarity protected		all connections
Short-circuit protection		pulsing
Voltage drop	U_d	≤ 3 V
Operating current	I_L	0 ... 100 mA
Off-state current	I_r	0 ... 0.5 mA typ. 0.1 μ A at 25 °C
No-load supply current	I_0	≤ 25 mA
Operating voltage display		LED, green
Indication of the switching state		LED, yellow

Functional safety related parameters

MTTF _d	780 a
Mission Time (T_M)	20 a
Diagnostic Coverage (DC)	0 %

Ambient conditions

Ambient temperature	-25 ... 70 °C (-13 ... 158 °F)
---------------------	--------------------------------

Mechanical specifications

Connection (system side)	PVC cable 5 m
Core cross-section (system side)	0.75 mm ²
Housing material	PBT
Sensing face	PBT
Protection degree	IP67

Compliance with standards and directives

Standard conformity	
Standards	EN 60947-5-2:2007 IEC 60947-5-2:2007

Approvals and certificates

UL approval	cULus Listed, General Purpose
CSA approval	cCSAus Listed, General Purpose
CCC approval	Products with a maximum operating voltage of ≤ 36 V do not bear a CCC marking because they do not require approval.