

Dual-Rod Cylinder

Series *CXS*

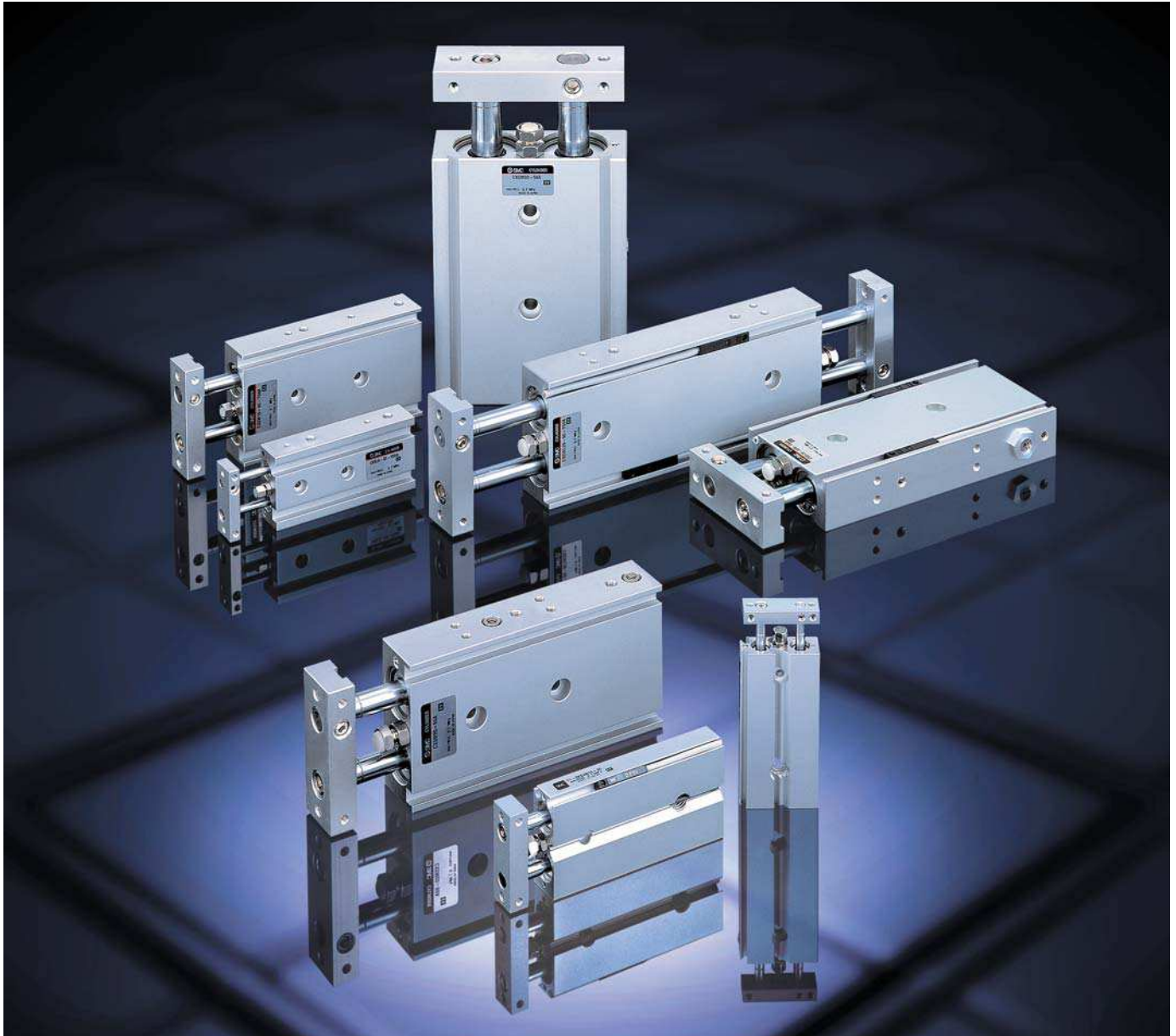

New:

- CXS Dual-Rod Cylinder with Air Cushion
- Compact Type Series CXSJ

Dual-Rod Cylinder with guide function for pick-and-place applications

Series CXS!

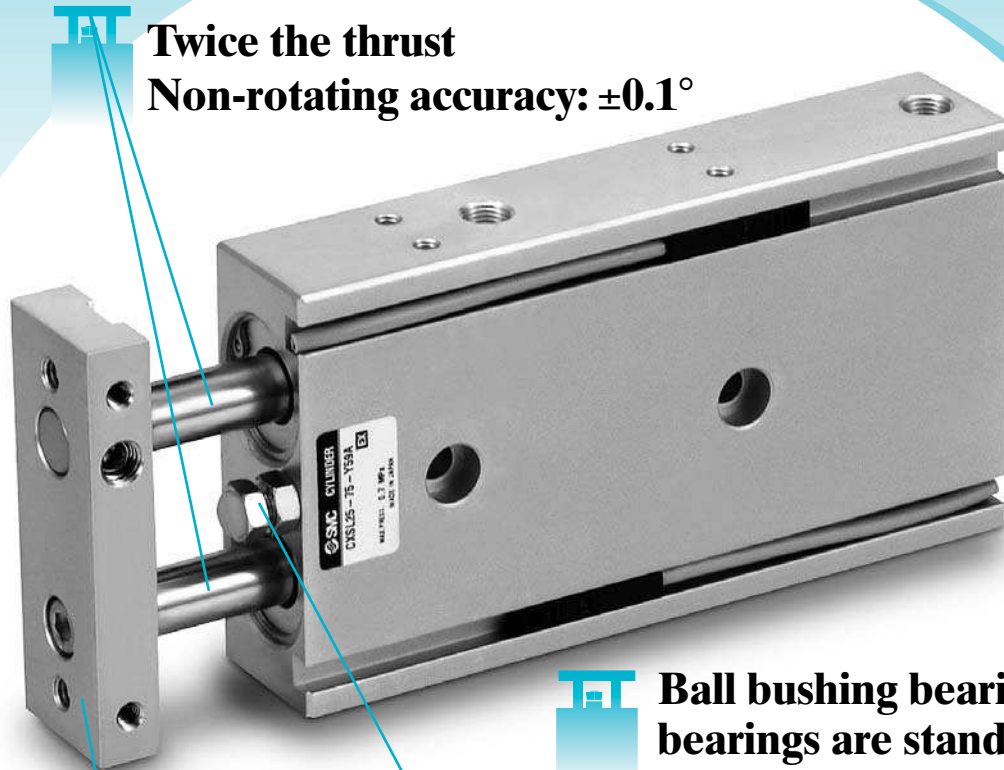

Twice the thrust
Non-rotating accuracy: $\pm 0.1^\circ$

Ball bushing bearings and slide bearings are standard for all series.
 Dimensions for ball bushing bearings and slide bearings are the same.

Adjustable stroke range: 0 to -5mm

3-side work piece mounting is a reality.

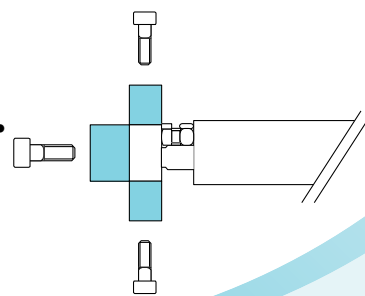

Variations

Series	Bore sizes (mm)	Axial piping	Clean room series	Made to Order Note)
	6 10 15 20 25 32		11- 12-	
New Compact type	CXSJ		(Ball bushing only)	Heat-resistant cylinder (XB6) Low-speed cylinder: 10 to 50mm/s (XB9) Low-speed cylinder: 5 to 10mm/s (XB13) High-speed cylinder (XB19) Long-stroke cylinder (XB11) NPT finish piping port (XC18) Fluoro rubber seal (XC22) Without plate (X593)
Standard type	CXS	(ø6 only)	(Ball bushing only)	
New With air cushion	CXS			
With end lock	CXS			
Dual-double-rod type	CXSW			

Note) Made to Order options are available for Series CXS standard type only. (Long stroke option XB11 is also available for CXSW.)
 Refer to "Made to Order Specifications" on pages 50 through 53 for details.

Two new additions: Compact type Air cushion type cylinders.

New

Compact type Series CXSJ: $\phi 6$, $\phi 10$

Smaller and lightweight

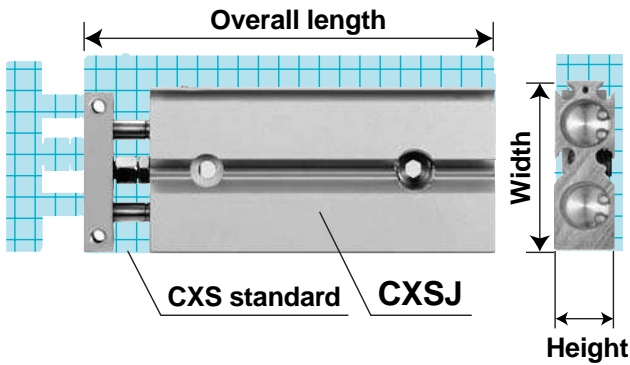

Bore size (mm)	Series	Dimensions (mm)			Weight (g)
		Height	Width	Overall length	
$\phi 6$	CXSJ□6	13.4	32	42 + Stroke	57
	CXS□6	16	37	58.5 + Stroke	95
$\phi 10$	CXSJ□10	15	42	56 + Stroke	114
	CXS□10	17	46	72 + Stroke	170

Superior mounting options

1 Auto switches can be verified from 4 directions.

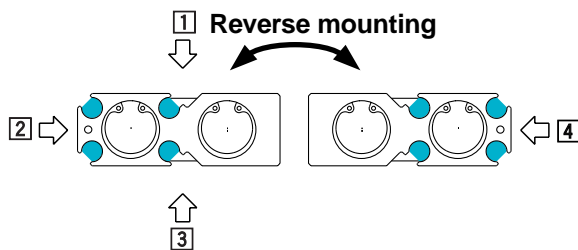

2 Symmetric mounting

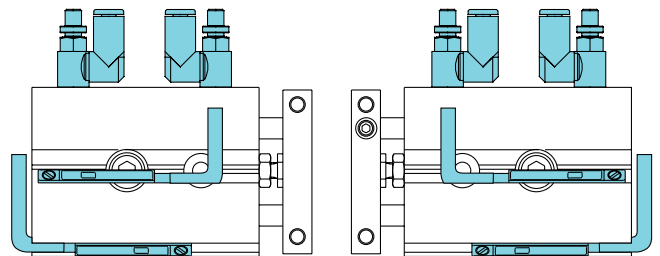

Reverse mounting mechanism

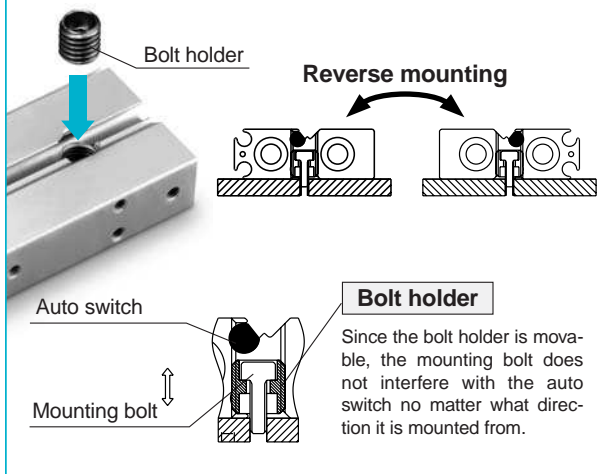

3 Axial piping

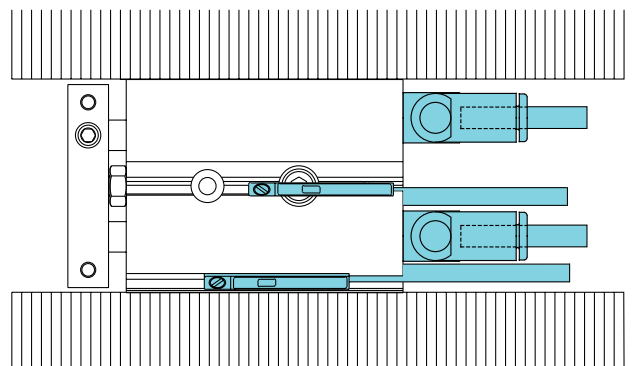

Allowable kinetic energy, allowable load, and non-rotating accuracy are equivalent to those of standard type CXS.

Dual-rod cylinder range is better than ever.

New

Air cushion type

Series CXS: $\varnothing 20$, $\varnothing 25$, $\varnothing 32$

Air cushion only minimally adds to overall length, compared with the standard type cylinder.

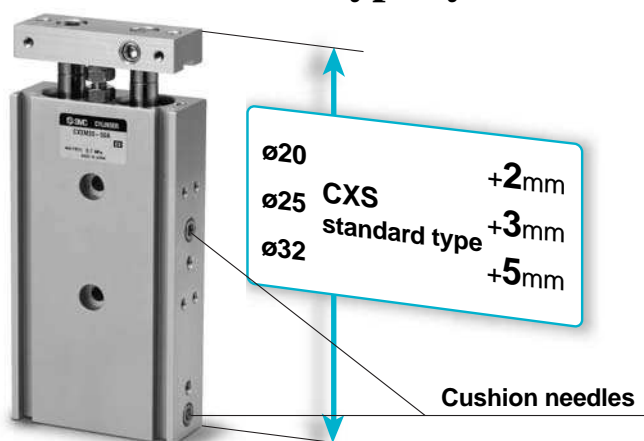

- 1 **Improved allowable kinetic energy:**
Two to three times that of the standard type
- 2 **Improved noise reduction:**
Reduction of more than 6dB is possible.

Unique air cushion mechanism with no cushion ring

Elimination of the cushion ring used in conventional type air cushions has made it possible to reduce the overall length of the cylinder while retaining all the advantages of a compact profile.

Operating principle

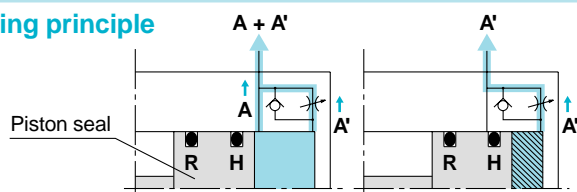

- ① When the piston is retracting, air is exhausted through both A and A' until piston seal H passes air passage A.
- ② After piston seal H has passed air passage A, air is exhausted only through A'. The section marked with slanted lines becomes a cushion chamber, and an air cushion effect is achieved.
- ③ When air is supplied for the piston extension, the check seal opens and the piston extends with no delay.



Clean room series

Series 11- CXSJ: $\varnothing 6$, $\varnothing 10$
Series 12- CXSJ: $\varnothing 6$, $\varnothing 10$

Series	Type	Bearing type
11-CXSJ	Vacuum specification	Slide bearing Ball bushing bearing
12-CXSJ	Relieving type Special treatment	Ball bushing bearing

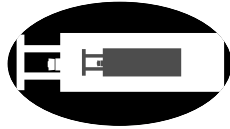

Compact Type
Series CXSJ
 ø6, ø10

New



Compact Type
 CXSJ



Standard Type
Series CXS
 ø6, ø10, ø15, ø20, ø25, ø32



Standard Type
 CXS

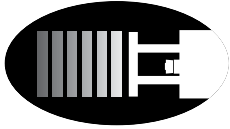

With Air Cushion
Series CXS
 ø20, ø25, ø32

New



With Air Cushion
 CXS



With End Lock
Series CXS
 ø6, ø10, ø15, ø20, ø25, ø32



With End Lock
 CXS

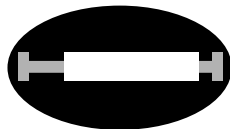

Dual-Double-Rod Type
Series CXSW
 ø6, ø10, ø15, ø20, ø25, ø32



Dual-Double-Rod Type
 CXSW

Auto Switches

Auto Switches

Made to Order

Made to Order

Precautions

Precautions

Compact Type Dual-Rod Cylinder

Series CXSJ

ø6, ø10

Compact Type
CXSJ

Standard Type
CXS

With Air Cushion
CXS

With End Lock
CXS

Dual-Double-Rod Type
CXS_W

Auto Switches

Made to Order

Precautions

How to Order

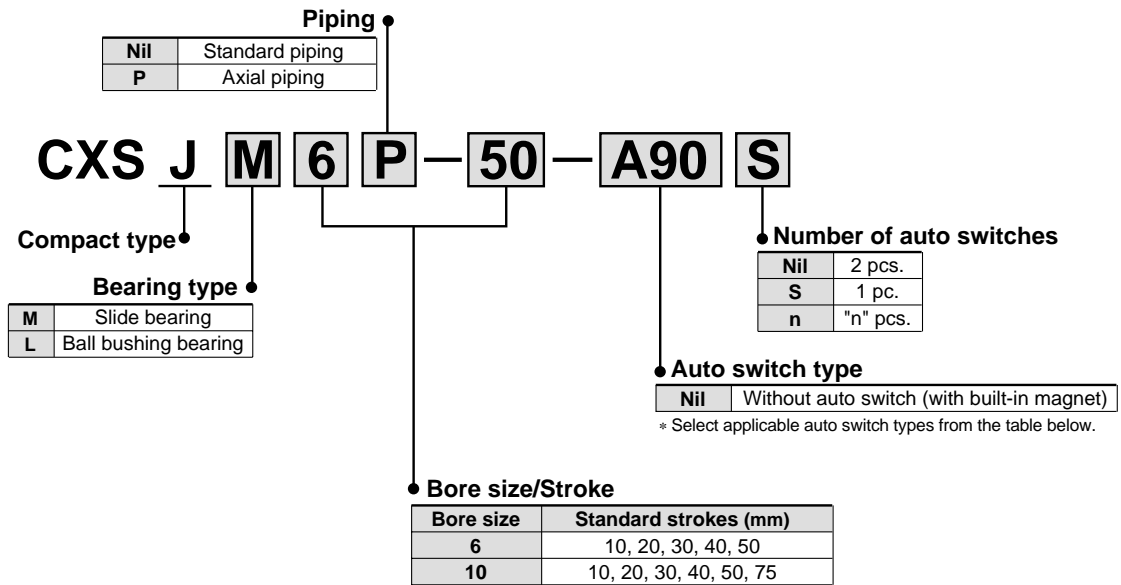

Applicable auto switches: Refer to pages 40 through 49 for detailed auto switch specifications.

Type	Special function	Electrical entry	Indicator light	Wiring (output)	Load voltage		Auto switch type		Lead wire length (m)*			Applicable loads		
					DC	AC	Electrical entry direction		0.5 (Nil)	3 (L)	5 (Z)			
							Perpendicular	In-line						
Reed switch	—	Grommet	No	2-wire	24V	5V, 12V	100V or less	A90V	A90	●	●	—	IC circuit	Relay PLC
						12V	100V	A93V	A93	●	●	—	—	
			Yes	3-wire (NPN equiv.)	—	5V	—	A96V	A96	●	●	—	IC circuit	—
Solid state switch	—	Grommet	Yes	3-wire (NPN)	24V	5V, 12V	—	F9NV	F9N	●	●	○	IC circuit	Relay PLC
				3-wire (PNP)				F9PV	F9P	●	●	○		
				2-wire				F9BV	F9B	●	●	○		
	3-wire (NPN)			F9NWV	F9NW	●	●	○	IC circuit					
	3-wire (PNP)			F9PWV	F9PW	●	●	○						
	2-wire			F9BWV	F9BW	●	●	○	—					
Water-resistant (2-colour display)	—	F9BA	—	●	○	—								

* Lead wire length symbols: 0.5m Nil (Example) A93
 3m L A93L
 5m Z F9NWZ

Note) Solid state switches marked "○" are produced upon receipt of order.

These auto switches have been changed
 Contact SMC or view www.smworld.com

F9N	⇒	M9N	F9NV	⇒	M9NV
F9P	⇒	M9P	F9PV	⇒	M9PV
F9B	⇒	M9B	F9BV	⇒	M9BV

Series CXSJ



Specifications

Bore size (mm)	6	10
Fluid	Air (non-lube)	
Proof pressure	1.05MPa	
Maximum operating pressure	0.7MPa	
Minimum operating pressure	0.15MPa	0.1MPa
Ambient and fluid temperature	-10° to 60°C (with no freezing)	
Piston speed ^{Note)}	30 to 800mm/s	
Cushion	Rubber bumper	
Stroke adjustable range	0 to -5mm compared to the standard stroke	
Port size	M3	M5

Note) The maximum piston speed shown in the table above is for extension.

The maximum piston speed for retraction is approximately 70% that of extension.

Standard Strokes

Model	Standard strokes	Manufacturable stroke range
CXSJ□6	10, 20, 30, 40, 50	60 to 100
CXSJ□10	10, 20, 30, 40, 50, 75	80 to 150

* Refer to "Made to Order" on page 51 for long strokes (i.e., strokes beyond the standard stroke range).

Non-standard strokes for a size ø6 cylinder are available as a special order.

Theoretical Output

Bore size (mm)	Rod size (mm)	Operating direction	Piston area (mm ²)	Operating pressure (MPa)							
				0.1	0.15	0.2	0.3	0.4	0.5	0.6	0.7
CXSJ□6	4	OUT	56	—	8.4	11.2	16.8	22.4	28.0	33.6	39.2
		IN	31	—	4.6	6.2	9.3	12.4	15.5	18.6	21.7
CXSJ□10	6	OUT	157	15.7	—	31.4	47.1	62.8	78.5	94.2	110
		IN	100	10.0	—	20.0	30.0	40.0	50.0	60.0	70.0

Note) Theoretical output (N) = Pressure (MPa) x Piston area (mm²)

Weights

Model	Standard stroke (mm)					
	10	20	30	40	50	75
CXSJM6	47	57	67	77	87	—
CXSJL6	48	58	68	78	88	—
CXSJM10	99	114	129	144	159	198
CXSJL10	106	121	136	151	166	205

Construction: Standard Piping

Compact Type
CXSJ

Standard Type
CX

With Air Cushion
CX

With End Lock
CX

Dual-Rod Type
CXSW

Auto
Switches

Made to
Order

Precautions

CXSJM (Slide bearing)

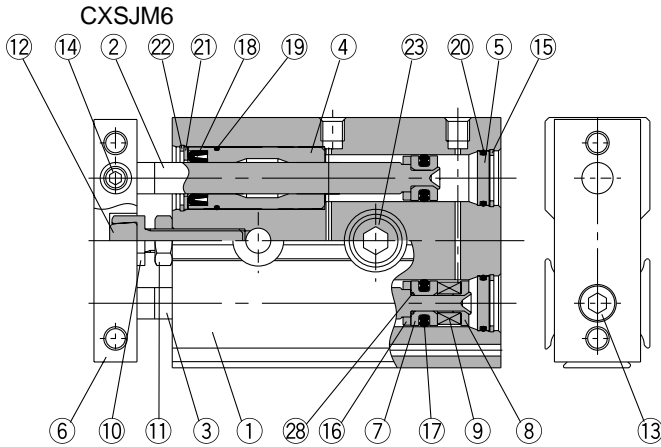

CXSJM10

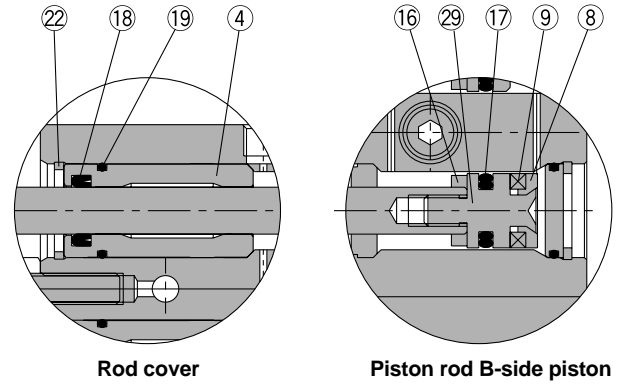

CXSJL (Ball bushing bearing)

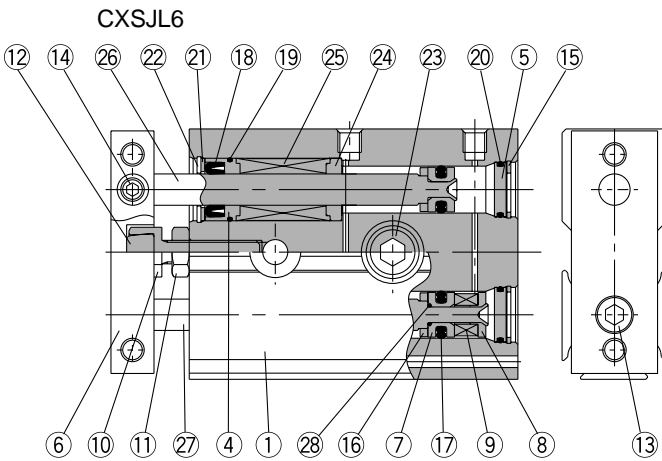

CXSJL10

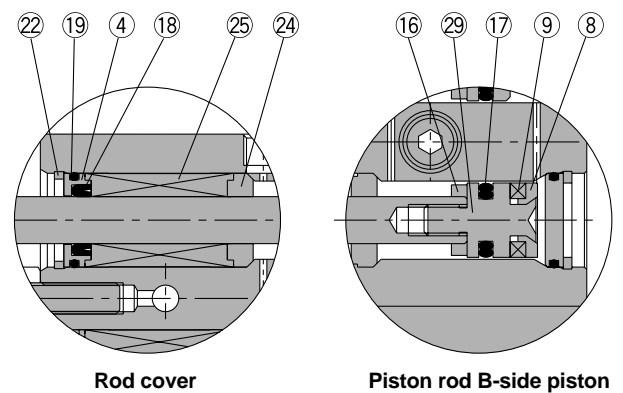

Parts list

No.	Description	Material	Note
1	Housing	Aluminum alloy	Hard anodized
2	Piston rod A	Carbon steel <small>Note)</small>	Hard chrome plated
3	Piston rod B	Carbon steel <small>Note)</small>	Hard chrome plated
4	Rod cover/Bearing	Aluminum alloy	
5	Head cover	Aluminum alloy	Anodized
6	Plate	Aluminum alloy	Glossy, self-coloring hard anodized
7	Piston A	Aluminum alloy	Chromated
8	Piston B	Aluminum alloy	Chromated
9	Magnet	Magnetic material	
10	Bumper bolt	Carbon steel	Nickel plated
11	Hexagon nut	Carbon steel	Nickel plated
12	Bumper	Polyurethane	
13	Hexagon socket head cap screw	Chromium steel	Nickel plated
14	Hexagon socket head set screw	Chromium steel	Nickel plated
15	Snap ring	Special steel	Nickel plated

Note) Stainless steel for CXSJM6.

No.	Description	Material	Note
16	Bumper B	Polyurethane	
17	Piston seal	NBR	
18	Rod seal	NBR	
19	O-ring	NBR	
20	O-ring	NBR	
21	Seal retainer	Stainless steel	
22	Snap ring B	Special steel	Nickel plated
23	Bolt holder	Stainless steel	
24	Bearing spacer	Aluminum alloy	
25	Ball bushing	—	
26	Piston rod A	Special steel	Hard chrome plated
27	Piston rod B	Special steel	Hard chrome plated
28	O-ring	NBR	
29	Piston C	Stainless steel	

Replacement parts: Seal kits

Model	Seal kit no.	Kit components
CXSJ□6	CXSJ6-PS	Items 17, 18, and 20 from the chart above
CXSJ□10	CXSJ10-PS	

Series CXSJ

Construction: Axial Piping

CXSJ□6P, CXSJ□10P

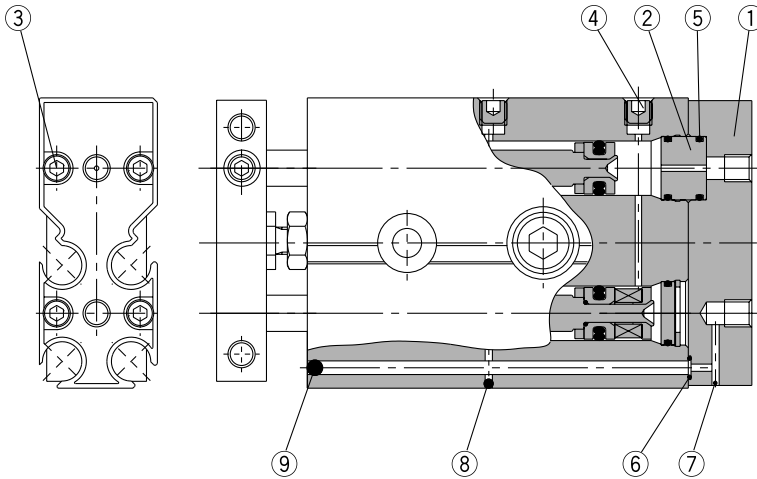

Parts list: Axial piping

No.	Description	Material	Note
1	Cover	Aluminum alloy	Hard anodized
2	Adapter	Aluminum alloy	Anodized
3	Hexagon socket head cap screw	Chromium steel	Nickel plated
4	Hexagon socket head plug	Chromium steel	Nickel plated
5	O-ring	NBR	
6	O-ring	NBR	
7	Steel ball	Special steel	Hard chrome plated
8	Steel ball	Special steel	Hard chrome plated
9	Steel ball	Special steel	Hard chrome plated

* Parts other than those listed above are the same as those for CXSJ standard type.

Clean Room Series

There are two types of cylinders, relieving type and vacuum type, available for a clean room environment. The relieving type specification with the double-seal construction of the rod section allows the cylinder to channel exhaust through the relief port directly to the outside of a clean room environment. The vacuum type specification allows for the application of a vacuum on the rod section while forced exhaust of air takes place through the vacuum port to the outside of a clean room environment.

How to Order

11 - CXSJ **M** Bore size - Stroke - Auto switch

● Bore size/Stroke

Bore size	Standard strokes (mm)
6	10, 20, 30, 40, 50
10	10, 20, 30, 40, 50

● Bearing type

M	Slide bearing
L*	Ball bushing bearing

* Only ball bushing bearing is available for "Clean room specification 12-".

● Clean room specification

11	Vacuum type
12	Relieving type (with specially treated sliding parts)

Specifications

Bore size (mm)	6	10
Proof pressure	1.05MPa	
Maximum operating pressure	0.7MPa	
Minimum operating pressure	0.15MPa	0.1MPa
Ambient and fluid temperature	-10° to 60°C (with no freezing)	
Piston speed	30 to 400mm/s	
Stroke adjustable range	0 to -5mm compared to the standard stroke	
Bearing type	Slide bearing, Ball bushing bearing	

* Refer to the separate clean room series catalog for dimensions.

Dimensions: $\phi 6$ Standard Piping

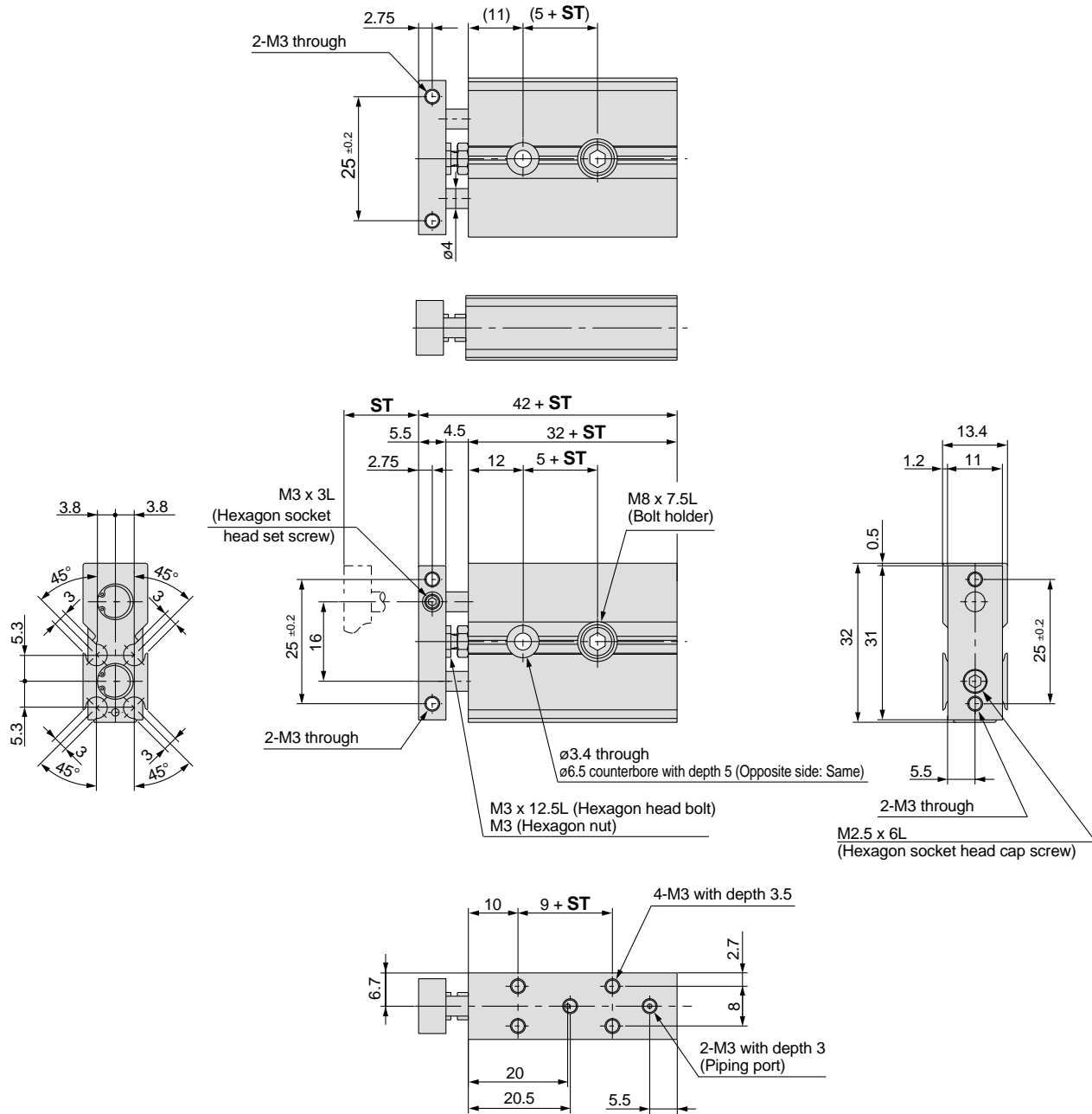

Part no.	ST	5 + ST	9 + ST	32 + ST	42 + ST
CXSJ□6-10	10	15	19	42	52
CXSJ□6-20	20	25	29	52	62
CXSJ□6-30	30	35	39	62	72
CXSJ□6-40	40	45	49	72	82
CXSJ□6-50	50	55	59	82	92

Series CXSJ

Dimensions: $\varnothing 10$ Standard Piping

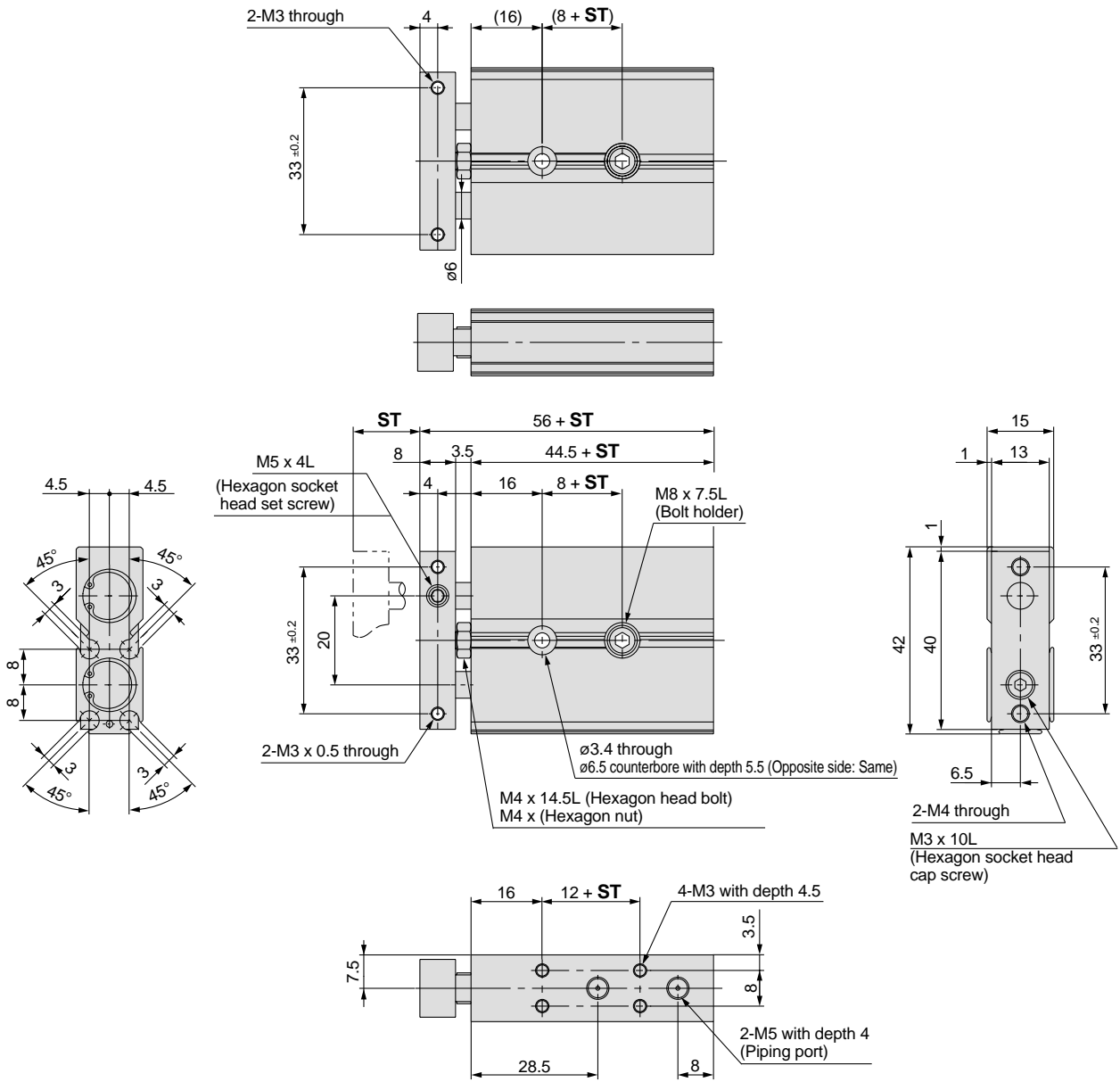

Part no.	ST	8 + ST	12 + ST	44.5 + ST	56 + ST
CXSJ□10-10	10	18	22	54.5	66
CXSJ□10-20	20	28	32	64.5	76
CXSJ□10-30	30	38	42	74.5	86
CXSJ□10-40	40	48	52	84.5	96
CXSJ□10-50	50	58	62	94.5	106
CXSJ□10-75	75	83	87	119.5	131

Dimensions: $\varnothing 6, \varnothing 10$ Axial Piping

CXSJ□6P

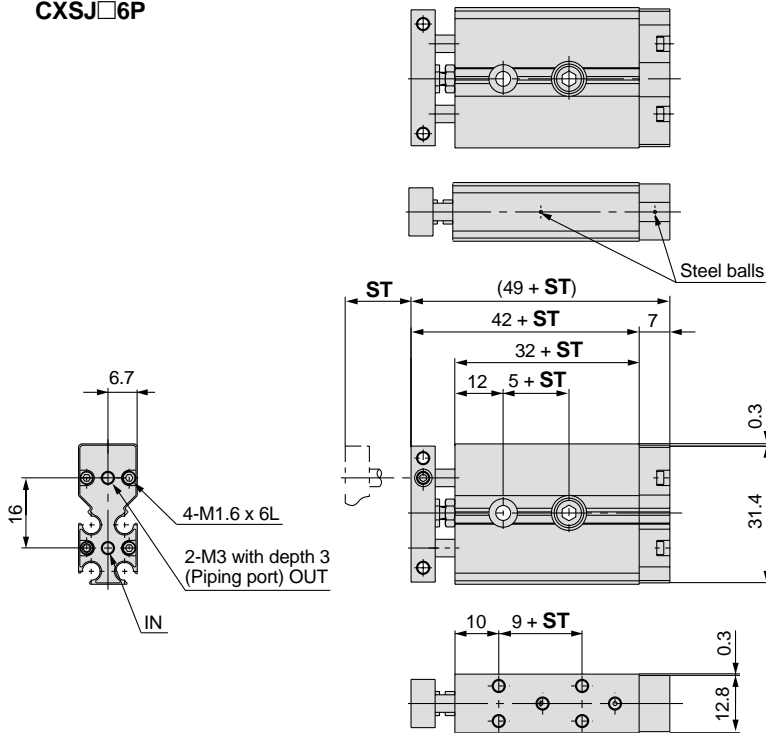

Part no.	ST	5 + ST	9 + ST	32 + ST	42 + ST	(49 + ST)
CXSJ□6P-10	10	15	19	42	52	59
CXSJ□6P-20	20	25	29	52	62	69
CXSJ□6P-30	30	35	39	62	72	79
CXSJ□6P-40	40	45	49	72	82	89
CXSJ□6P-50	50	55	59	82	92	99

* Dimensions other than those listed above are the same as for standard products.

CXSJ□10P

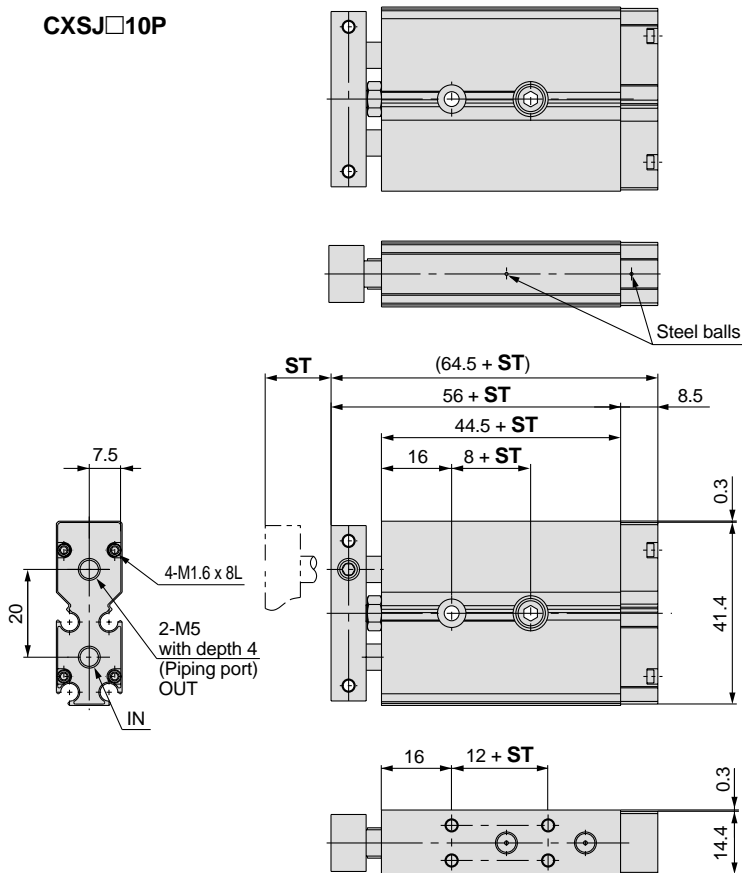

Part no.	ST	8 + ST	12 + ST	44.5 + ST	56 + ST	(64.5 + ST)
CXSJ□10P-10	10	18	22	54.5	66	74.5
CXSJ□10P-20	20	28	32	64.5	76	84.5
CXSJ□10P-30	30	38	42	74.5	86	94.5
CXSJ□10P-40	40	48	52	84.5	96	104.5
CXSJ□10P-50	50	58	62	94.5	106	114.5
CXSJ□10P-75	75	83	87	119.5	131	139.5

* Dimensions other than those listed above are the same as for standard products.

Series CXSJ

Auto Switch Proper Mounting Positions for Stroke End Detection

CXSJ□6

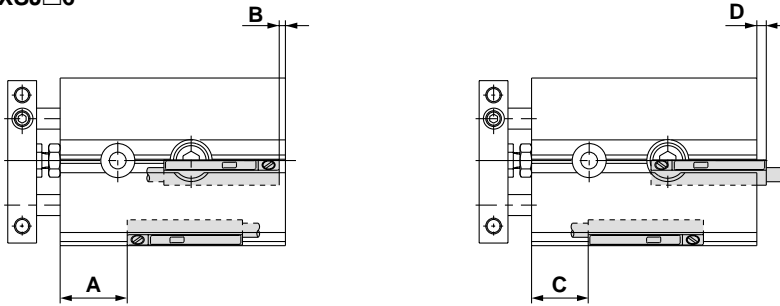

(mm)			
Symbol	D-A90, D-A96	D-A93	D-F9□
A	15.4	15.4	19.4
B (Note)	—	—	0.6
C	13.4	10.9	9.4
D	5.4	7.9	9.4

Note) For D-A90, D-A96, and D-A93, only outward electrical entry (D dimension) is available.

CXSJ□10

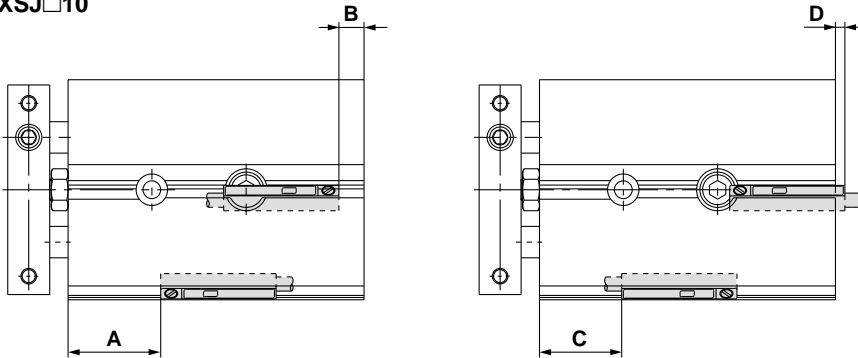

(mm)			
Symbol	D-A90, D-A96	D-A93	D-F9□
A	25.7	25.7	29.7
B (Note)	—	—	2.8
C	29.7	27.2	19.7
D	3.2	5.7	7.2

Note) For D-A90, D-A96, and D-A93, only outward electrical entry (D dimension) is available.

Auto switch mounting dimensions

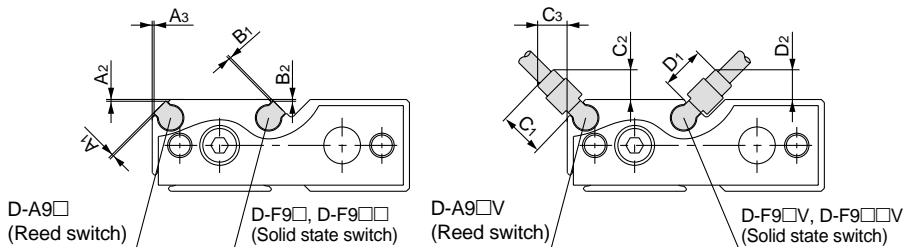

Switch types	Symbols	Bore sizes (mm)	
		6, 10	
D-A9□	A ₁	0.4	
	A ₂ , A ₃	0.3	
D-F9□, D-F9□□	B ₁	0.4	
	B ₂	0.3	
D-A9□V	C ₁	7.2	
	C ₂ , C ₃	4.8	
D-F9□V, D-F9□□V	D ₁	7.2	
	D ₂	4.8	

Auto Switch Mounting

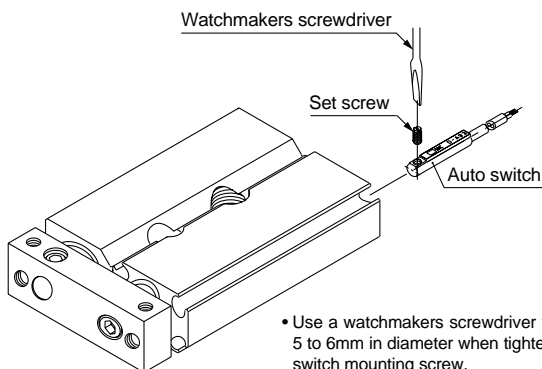

- Use a watchmaker's screwdriver with a handle 5 to 6mm in diameter when tightening the auto switch mounting screw.
- Tightening torque should be approximately 0.10 to 0.20N·m.

⚠ Caution

1. Take precautions when magnetic substances come in close proximity of a cylinder with auto switches.

When magnetic substances such as iron (including flanges) are in close proximity of an auto switch cylinder, be sure to provide a clearance between the magnetic substance and the cylinder body as shown in the drawing below. If the clearance is less than 10mm, the auto switch may not function properly.

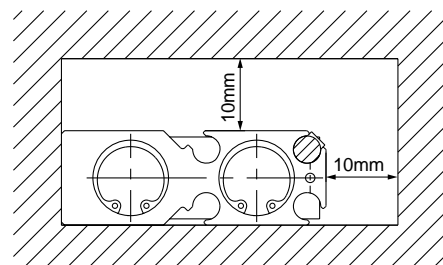

Standard Type Dual-Rod Cylinder

Series CXS

∅6, ∅10, ∅15, ∅20, ∅25, ∅32

How to Order

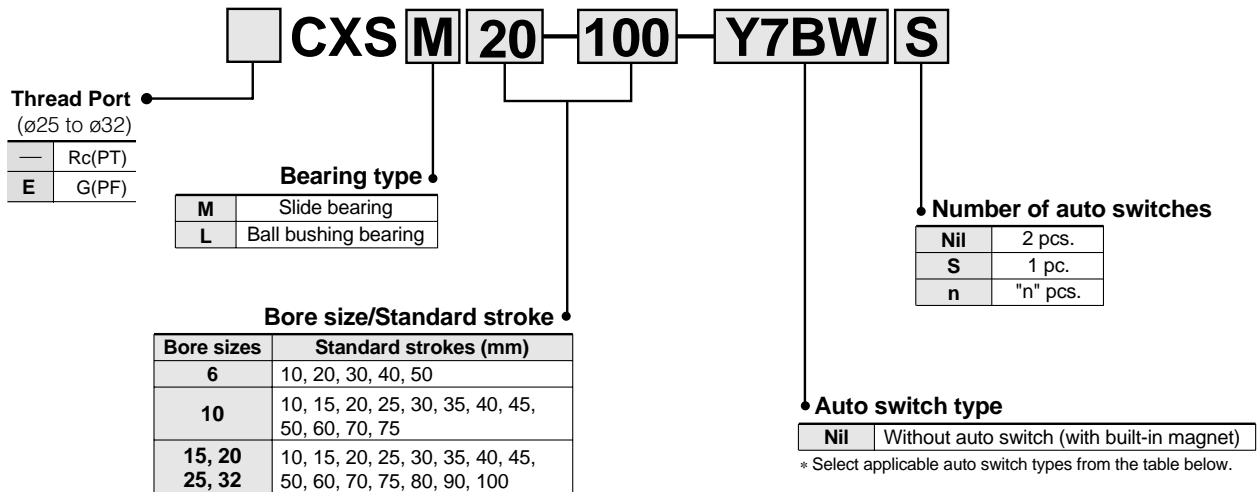

Applicable auto switches: Refer to pages 40 through 49 for detailed auto switch specifications.

Type	Special function	Electrical entry	Indicator light	Wiring (output)	Load voltage		Auto switch type		Lead wire length (m)*			Applicable loads		
					DC	AC	Electrical entry direction Perpendicular	In-line	0.5 (Nil)	3 (L)	5 (Z)			
Reed switch	—	Grommet	Yes	3-wire	—	5V	—	—	Z76	●	●	—	IC circuit	—
				2-wire	24V	12V	100V	—	Z73	●	●	●	—	Relay PLC
			No	—	5V, 12V	100V or less	—	Z80	●	●	—	IC circuit	—	
Solid state switch	—	Grommet	Yes	3-wire (NPN)	24V	5V, 12V	—	Y69A	Y59A	●	●	○	IC circuit	Relay PLC
				3-wire (PNP)				Y7PV	Y7P	●	●	○	—	
				2-wire				Y69B	Y59B	●	●	○	—	
	Diagnostic indication (2-colour display)			3-wire (NPN)	24V	5V, 12V	—	Y7NWV	Y7NW	●	●	○	IC circuit	—
				3-wire (PNP)				Y7PWV	Y7PW	●	●	○	—	
	Water-resistant (2-colour display)			2-wire	12V	—	Y7BWV	Y7BW	●	●	○	—	—	
				—			Y7BA	—	●	○	—			

* Lead wire length symbols: 0.5m Nil (Example) Y59A
 3m L Y59AL
 5m Z Y59AZ

Note) Solid state switches marked "○" are produced upon receipt of order.

Compact Type
CXSJ

Standard Type
CXS

With Air Cushion
CXS

With End Lock
CXS

Dual-Double-Rod Type
CXS_W

Auto Switches

Made to Order

Precautions

Series CXS



Specifications

Bore size (mm)	6	10	15	20	25	32
Fluid	Air (non-lube)					
Proof pressure	1.05MPa					
Maximum operating pressure	0.7MPa					
Minimum operating pressure	0.15MPa	0.1MPa		0.05MPa		
Ambient and fluid temperature	-10° to 60°C (with no freezing)					
Piston speed ^{Note)}	30 to 300mm/s	30 to 800mm/s	30 to 700mm/s		30 to 600mm/s	
Cushion	Rubber bumper					
Stroke adjustable range	0 to -5mm compared to the standard stroke					
Port size	M5				1/8	
Bearing type	Slide bearing, Ball bushing bearing (Same dimensions for both)					

Note) The maximum piston speed shown in the table above is for extension.
The maximum piston speed for retraction is approximately 70% that of extension.

Standard Strokes

Model	Standard strokes	Manufacturable stroke range
CXS□6	10, 20, 30, 40, 50	60 to 100
CXS□10	10, 15, 20, 25, 30, 35, 40, 45, 50, 60, 70, 75	80 to 150
CXS□15	10, 15, 20, 25, 30, 35, 40, 45, 50, 60, 70, 75, 80, 90, 100	110 to 150
CXS□20		110 to 200
CXS□25		
CXS□32		

* Refer to "Made to Order" on page 51 for long strokes (i.e., strokes beyond the standard stroke range).
Non-standard strokes for a size ø6 cylinder are available as a special order.



Made to Order Specifications

Refer to pages 50 through 53 for Series CXS Made to Order specifications.

Theoretical Output

Bore size (mm)	Rod size (mm)	Operating direction	Piston area (mm ²)	Operating pressure (MPa)							
				0.1	0.15	0.2	0.3	0.4	0.5	0.6	0.7
CXS□6	4	OUT	56	—	8.4	11.2	16.8	22.4	28.0	33.6	39.2
		IN	31	—	4.6	6.2	9.3	12.4	15.5	18.6	21.7
CXS□10	6	OUT	157	15.7	—	31.4	47.1	62.8	78.5	94.2	110
		IN	100	10.0	—	20.0	30.0	40.0	50.0	60.0	70.0
CXS□15	8	OUT	353	35.3	—	70.6	106	141	177	212	247
		IN	252	25.2	—	50.4	75.6	101	126	151	176
CXS□20	10	OUT	628	62.8	—	126	188	251	314	377	440
		IN	471	47.1	—	94.2	141	188	236	283	330
CXS□25	12	OUT	982	98.2	—	196	295	393	491	589	687
		IN	756	75.6	—	151	227	302	378	454	529
CXS□32	16	OUT	1608	161	—	322	482	643	804	965	1126
		IN	1206	121	—	241	362	482	603	724	844

Note) Theoretical output (N) = Pressure (MPa) x Piston area (mm²)

Weights

Model	Standard stroke (mm)														
	10	15	20	25	30	35	40	45	50	60	70	75	80	90	100
CXSM 6	0.081	—	0.095	—	0.108	—	0.122	—	0.135	—	—	—	—	—	—
CXSL 6	0.081	—	0.095	—	0.108	—	0.122	—	0.135	—	—	—	—	—	—
CXSM10	0.15	0.16	0.17	0.18	0.19	0.20	0.21	0.22	0.23	0.25	0.27	0.28	—	—	—
CXSL 10	0.15	0.16	0.17	0.18	0.19	0.20	0.21	0.22	0.23	0.25	0.27	0.28	—	—	—
CXSM15	0.25	0.265	0.28	0.29	0.30	0.315	0.33	0.345	0.36	0.39	0.42	0.435	0.45	0.48	0.51
CXSL 15	0.27	0.285	0.30	0.31	0.32	0.335	0.35	0.365	0.38	0.41	0.44	0.455	0.47	0.50	0.53
CXSM20	0.40	0.42	0.44	0.46	0.48	0.495	0.51	0.53	0.55	0.585	0.62	0.64	0.66	0.70	0.74
CXSL 20	0.43	0.445	0.46	0.48	0.50	0.515	0.53	0.55	0.57	0.605	0.64	0.66	0.68	0.715	0.75
CXSM25	0.61	0.635	0.66	0.69	0.72	0.745	0.77	0.80	0.83	0.89	0.95	0.97	0.995	1.06	1.10
CXSL 25	0.62	0.645	0.67	0.70	0.73	0.755	0.78	0.81	0.84	0.895	0.955	0.98	1.005	1.065	1.11
CXSM32	1.15	1.19	1.23	1.275	1.32	1.36	1.40	1.45	1.49	1.58	1.665	1.71	1.755	1.84	1.93
CXSL 32	1.16	1.205	1.25	1.295	1.34	1.38	1.42	1.465	1.51	1.595	1.68	1.72	1.765	1.855	1.94

Clean Room Series

There are two types of cylinders, relieving type and vacuum type, available for a clean room environment. The relieving type specification with the double-seal construction of the rod section allows the cylinder to channel exhaust through the relief port directly to the outside of a clean room environment. The vacuum type specification allows for the application of a vacuum on the rod section while forced exhaust of air takes place through the vacuum port to the outside of a clean room environment.

How to Order

12 – CXS L [Bore size] – [Stroke] – [Auto switch]

- Clean room specification
- Ball bushing bearing

11	Vacuum type
12	Relieving type (with specially treated sliding parts)

Specifications

Bore size (mm)	6	10	15	20	25	32
Proof pressure	1.05MPa					
Maximum operating pressure	0.7MPa					
Minimum operating pressure	0.15MPa	0.1MPa	0.05MPa			
Ambient and fluid temperature	-10° to 60°C (with no freezing)					
Piston speed	30 to 400mm/s					
Stroke adjustable range	0 to -5mm compared to the standard stroke					
Bearing type	Ball bushing bearing					

* Refer to the separate clean room series catalog for dimensions.

Copper-Free Air Cylinder Series (for cathode ray tube manufacturing process)

Copper and fluorine-free air cylinders help prevent the adverse effects of copper ions and halogen ions produced during CRT manufacturing.

Note) Standard cylinders are essentially copper and fluorine-free. However, to emphasize and ensure proper ordering (i.e., copper and fluorine-free specification) when combining with other specifications, add the code 20- in front of the the series as shown below.

How to Order

20 – CXS L [Bore size] – [Stroke] – [Auto switch]

- Copper-free series
- Ball bushing bearing

* Specifications and dimensions are the same as for standard products.

Series CXS

Operating Conditions

Maximum load weight

When the cylinder is mounted as shown in the diagrams below, the maximum load weight W should not exceed the values illustrated in the graph immediately following the diagrams.

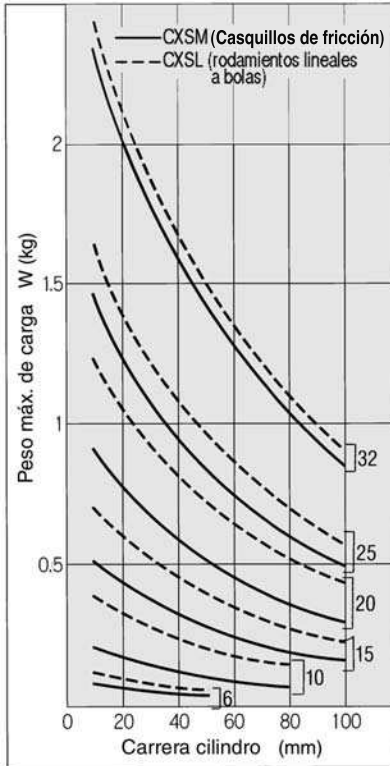
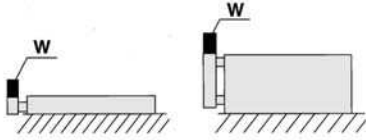

Non-rotating accuracy

Non-rotating accuracy θ° without a load should be less than or equal to the value provided in the table below as a guide.

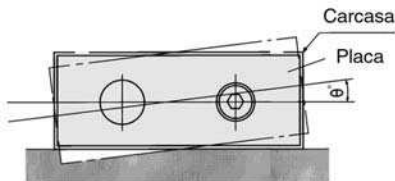

Bore size (mm)	$\phi 6$ to $\phi 32$
CXSM (Slide bearing)	$\pm 0.1^\circ$
CXSL (Ball bushing bearing)	

Deflection at the plate end

An approximate plate-end deflection X without a load is shown in the graph below.

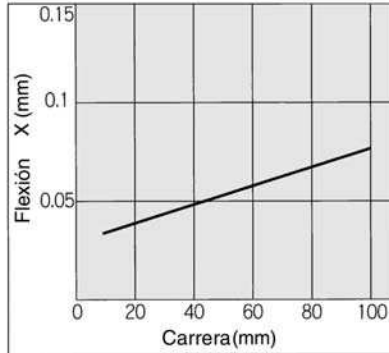
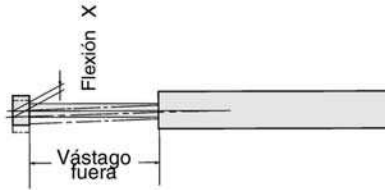

Allowable kinetic energy

Operate a vertically mounted cylinder with a load weight and cylinder speed not exceeding the ranges shown in the graph below. A horizontally mounted cylinder should also be operated with a load weight less than the ranges given in the graph at left.

Cylinder speed should be adjusted using a speed controller.

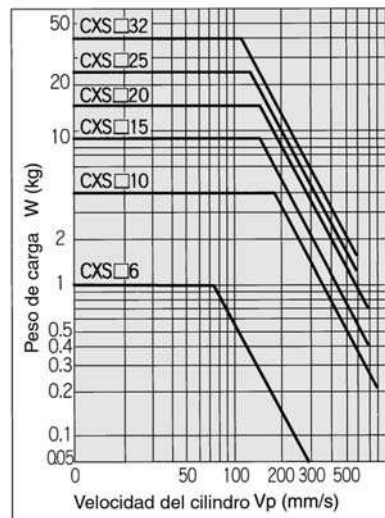

Construction: Slide Bearing

CXSM6

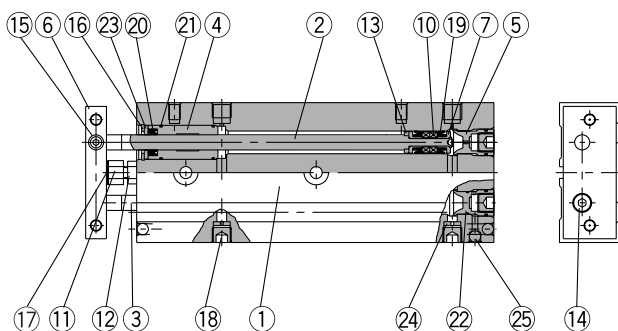

CXSM10

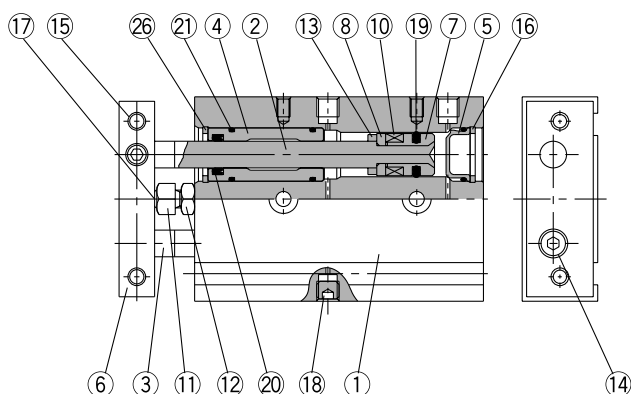

CXSM15

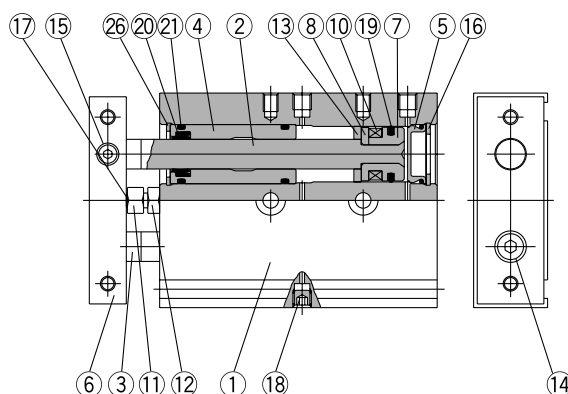

CXSM20 to 32

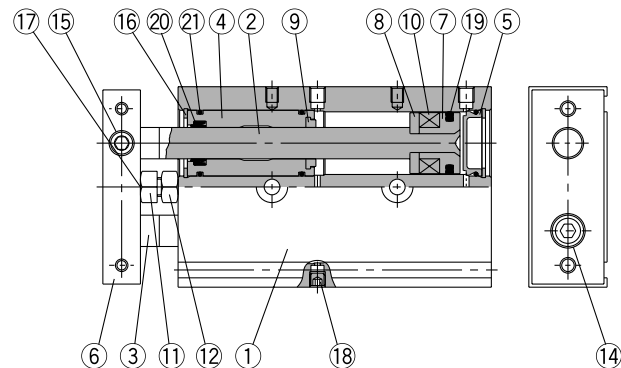

Parts list

No.	Description	Material	Note
1	Housing	Aluminum alloy	Hard anodized
2	Piston rod A	Carbon steel <i>Note 1)</i>	Hard chrome plated
3	Piston rod B	Carbon steel <i>Note 1)</i>	Hard chrome plated
4	Rod cover/Bearing	Aluminum alloy	
5	Head cover	Special steel <i>Note 2)</i>	
6	Plate	Aluminum alloy	Hard anodized
7	Piston A	Aluminum alloy	Chromated
8	Piston B	Aluminum alloy	Chromated
9	Bumper A	Polyurethane	
10	Magnet	Magnetic material	
11	Bumper bolt	Carbon steel	Nickel plated
12	Hexagon nut	Carbon steel	Nickel plated
13	Bumper B	Polyurethane	
14	Hexagon socket head cap screw	Chromium steel	Nickel plated
15	Hexagon socket head set screw	Chromium steel	Nickel plated
16	Snap ring	Special steel	Nickel plated



Note 1) Stainless steel for CXSM6.

Note 2) Anodized aluminum alloy for CXSM6.

Parts list

No.	Description	Material	Note
17	Bumper	Polyurethane	
18	Plug	Chromium steel	Nickel plated
19	Piston seal	NBR	
20	Rod seal	NBR	
21	O-ring	NBR	
22	Head cover B	Aluminum alloy	Nickel plated
23	Seal retainer	Aluminum alloy	
24	Port spacer	Aluminum alloy	
25	Steel ball	Special steel	Hard chrome plated
26	Snap ring B	Special steel	Nickel plated

Replacement parts: Seal Kits

Bore size (mm)	Seal kit no.	Kit components
6	CXSM 6-PS	Items 19 through 21 from the above chart
10	CXSM 10A-PS	
15	CXSM 15-PS	
20	CXSM 20-PS	
25	CXSM 25-PS	
32	CXSM 32-PS	

* Seal kits consist of items 19 through 21, and can be ordered by using the seal kit number corresponding to each bore size.

Series CXS

Construction: Ball Bushing Bearing

CXSL6

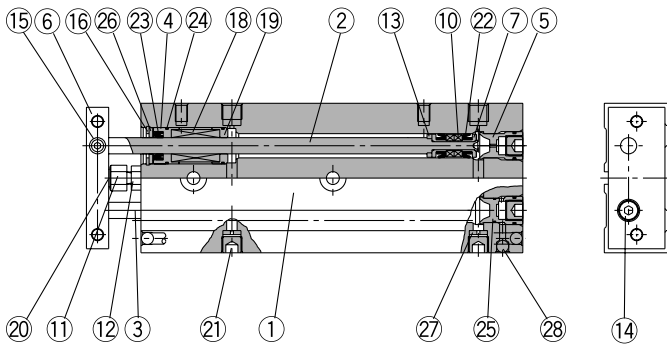

CXSL10

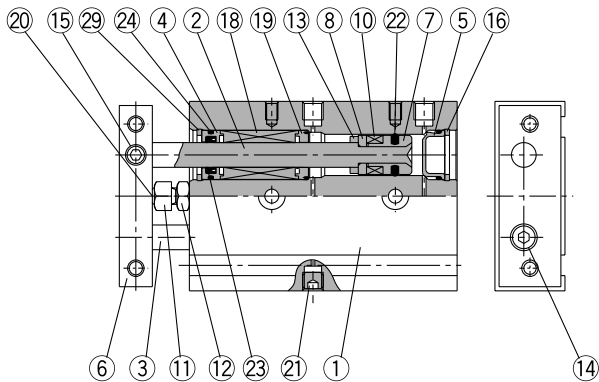

CXSL15

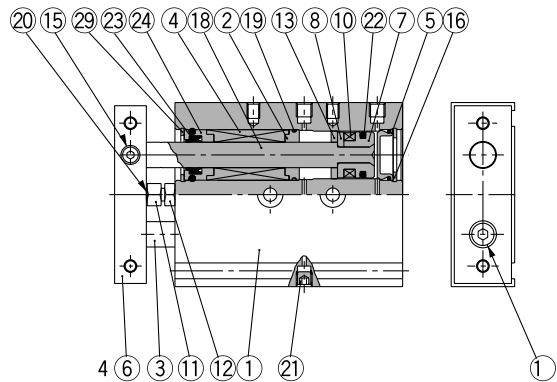

CXSL20 to 32

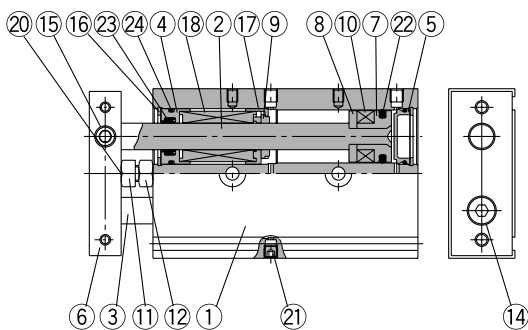

Parts list: Standard piping

No.	Description	Material	Note
1	Housing	Aluminum alloy	Hard anodized
2	Piston rod A	Special steel	Hard chrome plated
3	Piston rod B	Special steel	Hard chrome plated
4	Rod cover/Bearing	Aluminum alloy	
5	Head cover	Special steel <small>Note 1)</small>	
6	Plate	Aluminum alloy	Hard anodized
7	Piston A	Aluminum alloy	Chromated
8	Piston B	Aluminum alloy	Chromated
9	Bumper A	Polyurethane	
10	Magnet	Magnetic material	
11	Bumper bolt	Carbon steel	Nickel plated
12	Hexagon nut	Carbon steel	Nickel plated
13	Bumper B	Polyurethane	
14	Hexagon socket head cap screw	Chromium steel	Nickel plated
15	Hexagon socket head set screw	Chromium steel	Nickel plated
16	Snap ring	Special steel	Nickel plated
17	Bumper holder	Synthetic resin	

 Note 1) Anodized aluminum alloy for CXSL6.

Parts list

No.	Description	Material	Note
18	Ball bushing	—	
19	Bearing spacer	Synthetic resin <small>Note 2)</small>	
20	Bumper	Polyurethane	
21	Plug	Chromium steel	Nickel plated
22	Piston seal	NBR	
23	Rod seal	NBR	
24	O-ring	NBR	
25	Head cover B	Aluminum alloy	Nickel plated
26	Seal retainer	Aluminum alloy	
27	Port spacer	Aluminum alloy	
28	Steel ball	Special steel	Hard chrome plated
29	Snap ring B	Special steel	Nickel plated

Note 2) Aluminum alloy for CXSL6.

Replacement parts: Seal kits

Bore size (mm)	Seal kit no.	Kit components
6	CXSL 6-PS	Items 22 through 24 from the chart above
10	CXSL 10 B PS	
15	CXSL 15 A PS	
20	CXSL 20 A PS	
25	CXSL 25 A PS	
32	CXSL 32 A PS	

* Seal kits consist of items 22 through 24, and can be ordered by using the seal kit number corresponding to each bore size.

Standard Type Dual-Rod Cylinder *Series CXS*

Dimensions: $\phi 6$

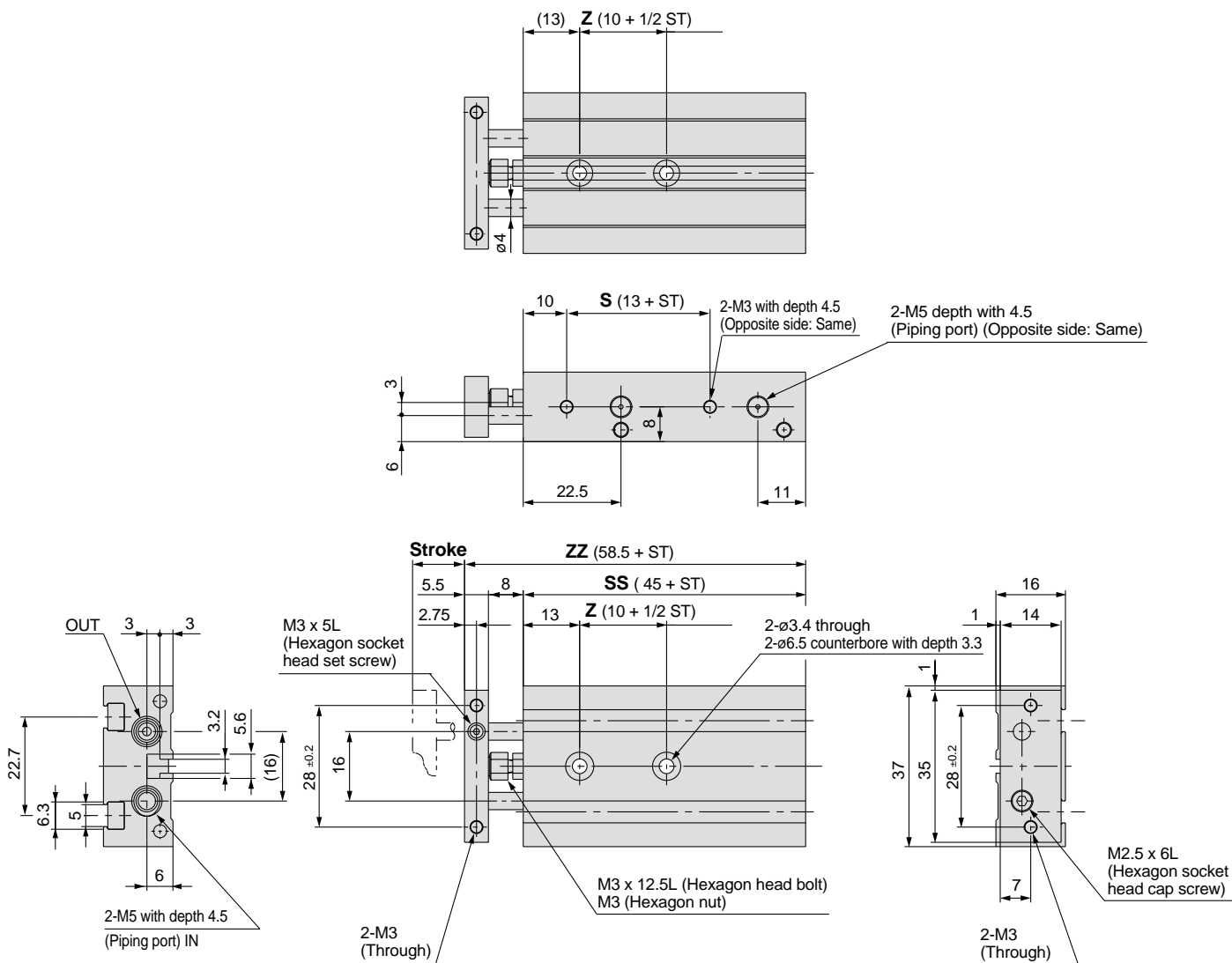

(mm)

Model	Stroke	Z	S	SS	ZZ
CXS□6-10	10	15	23	55	68.5
CXS□6-20	20	20	33	65	78.5
CXS□6-30	30	25	43	75	88.5
CXS□6-40	40	30	53	85	98.5
CXS□6-50	50	35	63	95	108.5

Series CXS

Dimensions: $\varnothing 10$, $\varnothing 15$

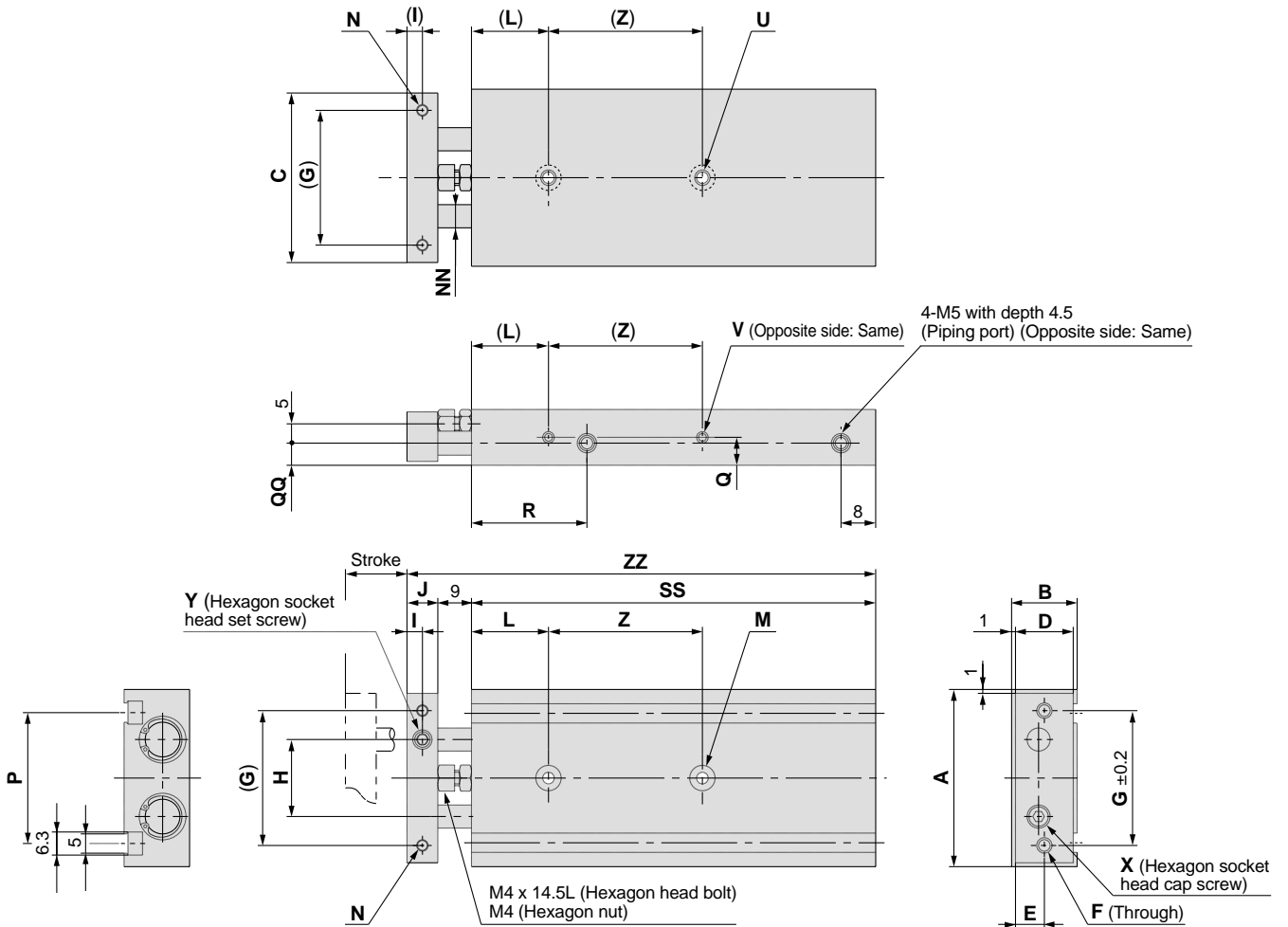

(mm)

Model	A	B	C	D	E	F	G	H	I	J	L	M	N	NN	P	Q	QQ	R	U	V	X	Y
CXS□10	46	17	44	15	7.5	2-M4	35	20	4	8	20	2- $\varnothing 3.4$ through 2- $\varnothing 6.5$ counterbore with depth 3.3	2-M3 with depth 5	$\varnothing 6$	33.6	8.5	7	30	2-M4 with depth 7	4-M3 with depth 4.5	M3 x 10	M5 x 5L
CXS□15	58	20	56	18	9	2-M5	45	25	5	10	30	2- $\varnothing 4.3$ through 2- $\varnothing 8$ counterbore with depth 4.4	2-M4 with depth 6	$\varnothing 8$	48	10	10	38.5	2-M5 with depth 8	4-M4 with depth 5	M5 x 10	M6 x 5L

Strokes

Model	SS														Z					ZZ															
	10	15	20	25	30	35	40	45	50	60	70	75	80	90	100	10, 15, 20, 25	30, 35, 40, 45, 50	60, 70, 75	80	90, 100	10	15	20	25	30	35	40	45	50	60	70	75	80	90	100
CXS□10	65	70	75	80	85	90	95	100	105	115	125	130	—	—	—	30	40	50	—	—	82	87	92	97	102	107	112	117	122	132	142	147	—	—	—
CXS□15	70	75	80	85	90	95	100	105	110	120	130	135	140	150	160	25	35	45	45	55	89	94	99	104	109	114	119	124	129	139	149	154	159	169	179

Standard Type Dual-Rod Cylinder *Series CXS*

Dimensions: $\phi 20$, $\phi 25$, $\phi 32$

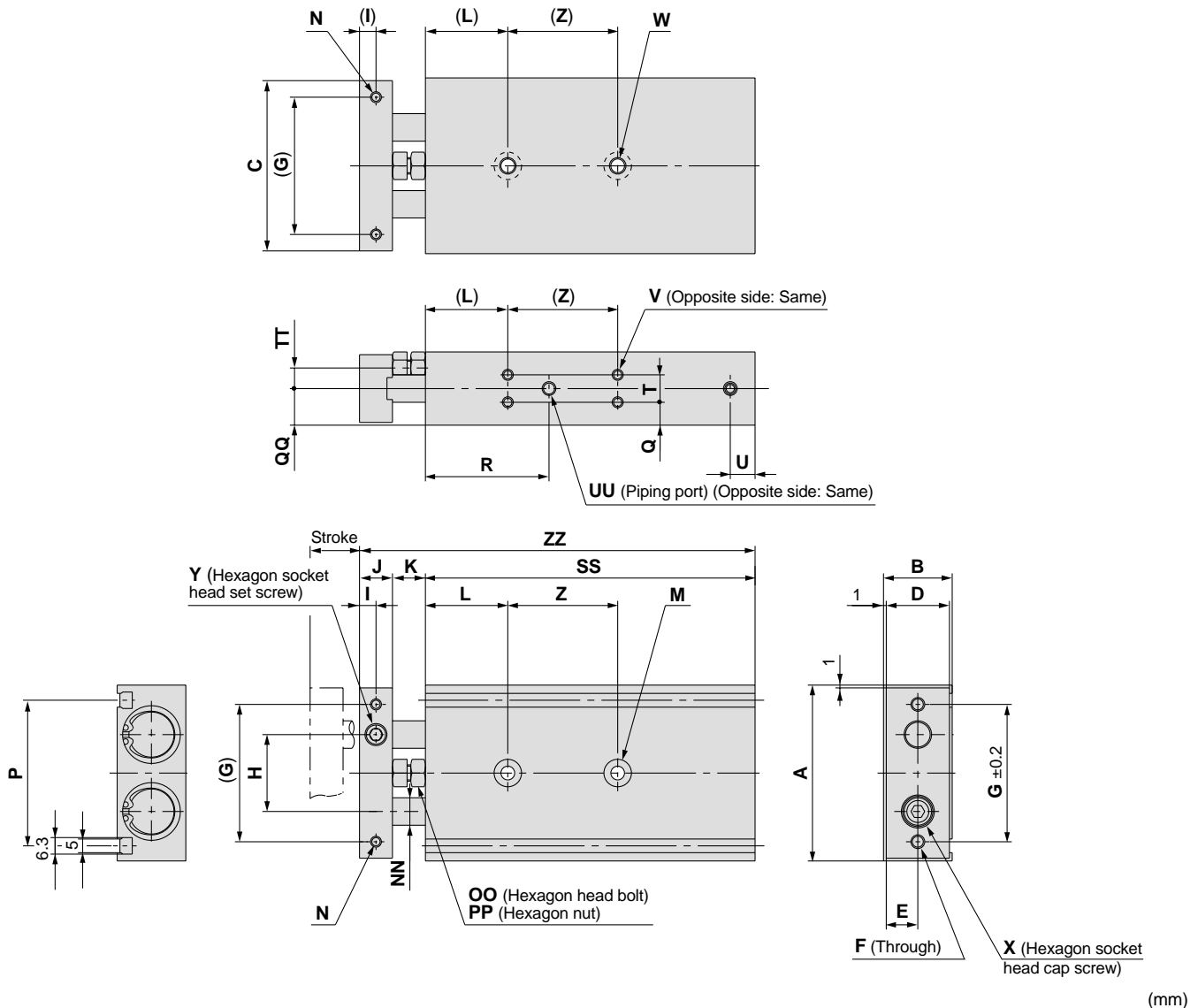

(mm)

Model	A	B	C	D	E	F	G	H	I	J	K	L	M	N	NN	OO	P
CXS□20	64	25	62	23	11.5	2-M5	50	28	6	12	12	30	2- $\phi 5.5$ through 2- $\phi 9.5$ counterbore with depth 5.3	2-M4 with depth 6	$\phi 10$	M6 x 18.5L	53
CXS□25	80	30	78	28	14	2-M6	60	35	6	12	12	30	2- $\phi 6.9$ through 2- $\phi 11$ counterbore with depth 6.3	2-M5 with depth 7.5	$\phi 12$	M6 x 18.5L	64
CXS□32	98	38	96	36	18	2-M6	75	44	8	16	14	30	2- $\phi 6.9$ through 2- $\phi 11$ counterbore with depth 6.3	2-M5 with depth 8	$\phi 16$	M8 x 23L	76

Model	PP	Q	QQ	R	T	TT	U	UU	V	W	X	Y
CXS□20	M6	7.75	12.5	45	9.5	6.5	8	4-M5 with depth 4.5	8-M4 with depth 5.5	2-M6 with depth 10	M6 x 12	M8 x 6L
CXS□25	M6	8.5	15	46	13	9	9	4-1/8 with depth 6.5	8-M5 with depth 7.5	2-M8 with depth 12	M6 x 14	M8 x 6L
CXS□32	M8	9	19	56	20	11.5	10	4-1/8 with depth 6.5	8-M5 with depth 7.5	2-M8 with depth 12	M8 x 16	M10 x 8L

Strokes

Model	SS																Z			ZZ															
	10	15	20	25	30	35	40	45	50	60	70	75	80	90	100	10, 15, 20, 25	30, 35, 40, 45, 50	60, 70, 75, 80, 90, 100	10	15	20	25	30	35	40	45	50	60	70	75	80	90	100		
CXS□20	80	85	90	95	100	105	110	115	120	130	140	145	150	160	170	30	40	60	104	109	114	119	124	129	134	139	144	154	164	169	174	184	194		
CXS□25	82	87	92	97	102	107	112	117	122	132	142	147	152	162	172	30	40	60	106	111	116	121	126	131	136	141	146	156	166	171	176	186	196		
CXS□32	92	97	102	107	112	117	122	127	132	142	152	157	162	172	182	40	50	70	122	127	132	137	142	147	152	157	162	172	182	187	192	202	212		

Compact Type CXSJ
 Standard Type CXS
 With Air Cushion CXS
 With End Lock CXS
 Dual-Double-Rod Type CXSW
 Auto Switches
 Made to Order
 Precautions

Series CXS

Auto Switch Proper Mounting Positions for Stroke End Detection

Electrical entry direction: Inward

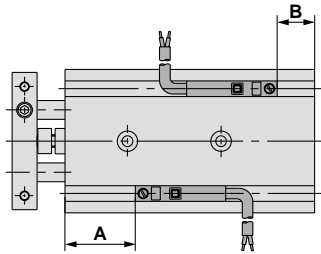

Electrical entry direction: Outward

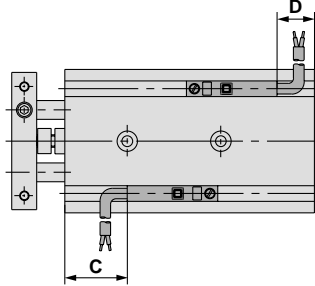

Bore size (mm)	A	B	D-Z7, D-Z8, D-Y7□W D-Y5□, D-Y7□		D-Y6□, D-Y7□V D-Y7□WV		D-Y7BAL	
			C	D	C	D	C	D
6	15.5	4.5	11.5 (10)	0.5 (-1)	13	2	5.5	-5.5
10	22.5	7.5	18.5 (17)	3.5 (2)	20	5	12.5	-2.5
15	30.5	4.5	26.5 (25)	0.5 (-1)	28	2	20.5	-5.5
20	38	7	34 (32.5)	3 (1.5)	36	4.5	28	-3
25	38	9	34 (32.5)	5 (3.5)	36	6.5	28	-1
32	48	9	44 (42.5)	5 (3.5)	46	6.5	38	-1



Lead wire entry is inward prior to shipment.

Notes) • Negative values for dimension D indicate how much the lead wires protrude from the cylinder body.

• Dimensions inside () are for D-Z73.

Auto Switch Mounting Dimensions

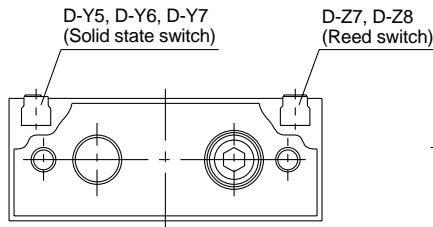

Dimension A

Switch types	Bore size					
	6	10	15	20	25	32
D-Y59A, D-Y7P, D-Y59B D-Y69A, D-Y7PV, D-Y69B	0.7		0.2			
D-Y7NWV, D-Y7PWV, D-Y7BWV D-Y7NW, D-Y7PW, D-Y7BW	6.5		6.0			
D-Z7, D-Z8	1.2		0.7			

Auto Switch Mounting

When mounting and securing auto switches, they should be inserted into the cylinder's switch mounting rail from the direction shown in the drawing below. After setting in the mounting position, use a flat head watchmakers screwdriver to tighten the set screw that is included.

Note) When tightening the auto switch mounting screw, use a watchmakers screwdriver with a handle about 5 to 6mm in diameter. Tighten with a torque of 0.05 to 0.1N·m. As a rule, the mounting screw should be turned about 90° past the point at which tightening can first be felt.

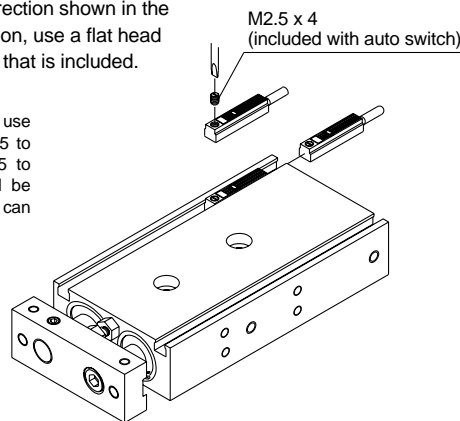

Caution

1. Take precautions when magnetic substances come in close proximity of the cylinder with auto switches.

When magnetic substances such as iron (including flanges) are in close proximity of an auto switch cylinder, be sure to provide a clearance between the magnetic substance and the cylinder body as shown in the drawing below. If the clearance is less than the values noted in the table below, the auto switch may not function properly.

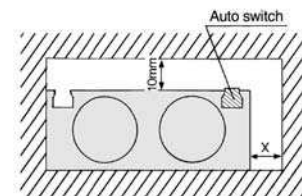

Bore size	X (mm)
ø6	0
ø10	0
ø15	10
ø20	10
ø25	0
ø32	0

Dual-Rod Cylinder with Air Cushion

Series CXS

ø20, ø25, ø32



How to Order

Port thread type

Symbol	Type	Bore sizes
Nil	M	ø20
	Rc	
TN	NPT	ø25, ø32
TF	G	

CXS M 20 100 A Y7BW S

Dual-rod cylinder

Bearing type

Symbol	Type
M	Slide bearing
L	Ball bushing bearing

Bore size/Stroke

Bore sizes	Strokes (mm)
20	20, 25, 30, 35, 40, 45, 50, 60, 70, 75, 80, 90, 100
25, 32	25, 30, 35, 40, 45, 50, 60, 70, 75, 80, 90, 100

Number of auto switches

Symbol	Type
Nil	2 pcs.
S	1 pc.
n	"n" pcs.

Auto switch type

Symbol	Type
Nil	Without auto switch (with built-in magnet)

* Select applicable auto switch types from the table below.

Air cushion

Applicable auto switches: Refer to pages 40 through 49 for detailed auto switch specifications.

Type	Special function	Electrical entry	Indicator light	Wiring (output)	Load voltage		Auto switch type		Lead wire length (m)*			Applicable loads		
					DC	AC	Electrical entry direction	Perpendicular	In-line	0.5 (Nil)	3 (L)	5 (Z)		
Reed switch	—	Grommet	Yes	3-wire	—	5V	—	—	Z76	●	●	—	IC circuit	—
				2-wire	24V	12V	100V	—	Z73	●	●	●	—	Relay PLC
			No	—	5V, 12V	100V or less	—	Z80	●	●	—	IC circuit	—	
Solid state switch	—	Grommet	Yes	3-wire (NPN)	24V	5V, 12V	—	Y69A	Y59A	●	●	○	IC circuit	Relay PLC
				3-wire (PNP)				Y7PV	Y7P	●	●	○	—	
				2-wire				Y69B	Y59B	●	●	○	—	
	3-wire (NPN)			5V, 12V	Y7NWV	Y7NW	●	●	○	IC circuit				
	3-wire (PNP)				Y7PWV	Y7PW	●	●	○	—				
	Diagnostic indication (2-colour display)			2-wire	Y7BWV	Y7BW	●	●	○	—				
					—	Y7BA	—	●	○	—				
Water-resistant (2-colour display)	—	—	—	—	—	—	—	—	—	—	—	—		

* Lead wire length symbols: 0.5m Nil (Example) Y59A
 3m L Y59AL
 5m Z Y59AZ

Note) Solid state switches marked "○" are produced upon receipt of order.

⚠ Specific Product Precautions

Be sure to read before handling.
Refer to pages 64 through 70 for Safety Instructions, Actuator Precautions, and Auto Switch Precautions.

Selection

⚠ Caution

1. Operate the cylinder until the stroke end.

If the stroke is restricted by the external stopper and clamp work piece, effective cushioning and noise reduction will not be achieved.

2. Adjust the cushion needles to absorb the kinetic energy during the cushion stroke so that excessive kinetic energy does not remain when the piston reaches the stroke end.

If the piston reaches the stroke end with excessive kinetic energy remaining (more than the values given in table 1 below) due to an improper adjustment, excessive impact will occur, causing damage to machinery.

Table 1. Allowable kinetic energy at piston impact

Bore size (mm)	20	25	32
Piston speed (mm/s)	50 to 700	50 to 600	50 to 600
Allowable kinetic energy (J)	0.17	0.271	0.32

Cushion Needle Adjustment

⚠ Caution

1. Keep the adjustment range for the cushion needles between the fully closed position and the rotations shown below.

Bore size (mm)	20	25	32
Rotations	2.5 rotations or less	3 rotations or less	

Use a 3mm flat head watchmakers screwdriver to adjust the cushion needles. Never set the cushion needles to the fully closed position, as this will cause damage to the seals. The adjustment range for the cushion needles must be between the fully closed position and the open position ranges indicated in the table above. A retaining mechanism prevents the cushion needles from slipping out; however, they may spring out during operation if they are rotated beyond the ranges shown above.

Precautions for selection standard, mounting, piping, and operating environment are same as for the standard series.

Specifications

Bore size (mm)	20	25	32
Fluid	Air (non-lube)		
Proof pressure	1.05MPa		
Maximum operating pressure	0.7MPa		
Minimum operating pressure	0.1MPa		
Ambient and fluid temperature	-10° to 60°C (with no freezing)		
Piston speed ^{Note)}	50 to 1000mm/s		
Port size	M5	Rc 1/8 (NPT 1/8, G 1/8)	
Bearing type	Slide bearing, Ball bushing bearing (Same dimensions for both)		
Cushion	Air cushion (both sides)		

Note) The maximum piston speed shown in the table above is for extension.
The maximum piston speed for retraction is approximately 70% that of extension.

Cushion Mechanism

Bore size (mm)	Effective cushion length (mm)	Absorbable kinetic energy (J)
20	5.9	0.40
25	5.7	0.75
32	5.6	1.0

Standard Strokes

Model	Standard strokes (mm)
CXS□20	20, 25, 30, 35, 40, 45, 50, 60, 70, 75, 80, 90, 100
CXS□25 CXS□32	25, 30, 35, 40, 45, 50, 60, 70, 75, 80, 90, 100

* Refer to "Made to Order" on page 51 for long strokes (i.e., strokes beyond the standard stroke range).

Theoretical Output

Model	Rod size (mm)	Operating direction	Piston area (mm ²)	Operating pressure (MPa)						
				0.1	0.2	0.3	0.4	0.5	0.6	0.7
CXS□20	10	OUT	628	62.8	126	188	251	314	377	440
		IN	471	47.1	94.2	141	188	236	283	330
CXS□25	12	OUT	982	98.2	196	295	393	491	589	687
		IN	756	75.6	151	227	302	378	454	529
CXS□32	16	OUT	1608	161	322	482	643	804	965	1126
		IN	1206	121	241	362	482	603	724	844

Note) Theoretical output (N) = Pressure (MPa) x Piston area (mm²)

Weights

Model	Standard stroke (mm)												
	20	25	30	35	40	45	50	60	70	75	80	90	100
CXSM20-□A	0.50	0.52	0.54	0.56	0.58	0.60	0.62	0.66	0.70	0.715	0.735	0.755	0.815
CXSL20-□A	0.52	0.54	0.56	0.58	0.60	0.62	0.64	0.68	0.72	0.735	0.755	0.775	0.835
CXSM25-□A	—	0.78	0.80	0.82	0.84	0.86	0.88	0.92	0.96	0.98	1.00	1.04	1.08
CXSL25-□A	—	0.79	0.81	0.83	0.85	0.87	0.89	0.93	0.97	0.99	1.01	1.05	1.09
CXSM32-□A	—	1.48	1.53	1.575	1.62	1.67	1.72	1.82	1.92	1.96	2.06	2.14	2.20
CXSL32-□A	—	1.51	1.55	1.60	1.64	1.69	1.74	1.84	1.94	1.98	2.08	2.16	2.22

Construction

CXSM with air cushion

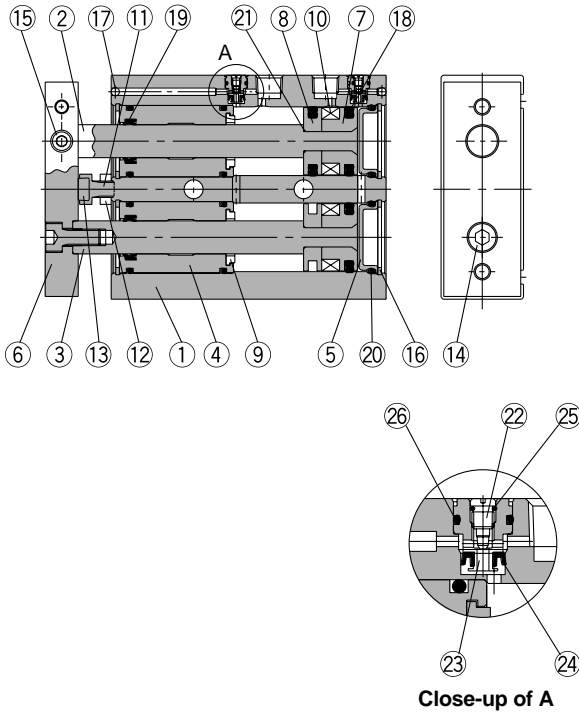

CXSL with air cushion

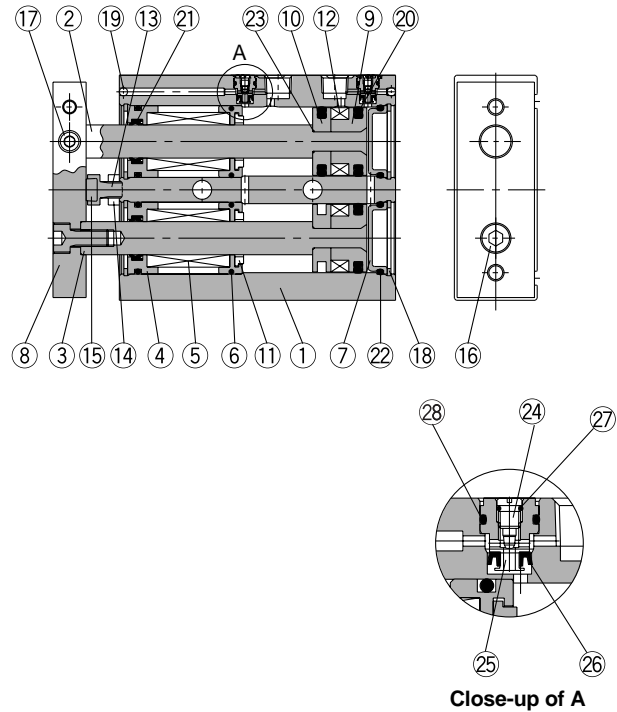

CXSM: Parts list

No.	Description	Material	Note
1	Housing	Aluminum alloy	Hard anodized
2	Piston rod A	Carbon steel	Hard chrome plated
3	Piston rod B	Carbon steel	Hard chrome plated
4	Rod cover/Bearing	Aluminum alloy	
5	Head cover	Special steel	Electroless nickel plated
6	Plate	Aluminum alloy	Glossy, self-coloring hard anodized
7	Piston A	Aluminum alloy	Chromated
8	Piston B	Aluminum alloy	Chromated
9	Bumper B	Polyurethane	
10	Magnet	Magnetic material	
11	Bumper bolt	Carbon steel	Nickel plated
12	Hexagon nut	Carbon steel	Nickel plated
13	Bumper	Polyurethane	
14	Hexagon socket head cap screw	Chromium steel	Nickel plated
15	Hexagon socket head set screw	Chromium steel	Nickel plated
16	Snap ring	Special steel	Nickel plated
17	Steel ball	Special steel	Nickel plated
18	Piston seal	NBR	
19	Rod seal	NBR	
20	O-ring	NBR	
21	O-ring	NBR	
22	Cushion needle	Stainless steel	
23	Check seal retainer	Copper alloy	
24	Check seal	NBR	
25	Needle gasket	NBR	
26	Check gasket	NBR	

Replacement parts: Seal kits

Bore size (mm)	Seal kit no.	Kit components
20	CXS□20A-PS	Items 18 through 20 from the chart above
25	CXS□25A-PS	
32	CXS□32A-PS	

* Seal kits consist of items 18 through 20, and can be ordered by using the seal kit number corresponding to each bore size.

CXSL: Parts list

No.	Description	Material	Note
1	Housing	Aluminum alloy	Hard anodized
2	Piston rod A	Special steel	Hard chrome plated
3	Piston rod B	Special steel	Hard chrome plated
4	Rod cover/Bearing	Aluminum alloy	
5	Ball bushing	—	
6	Bumper holder	Synthetic resin	
7	Head cover	Special steel	Electroless nickel plated
8	Plate	Aluminum alloy	Glossy, self-coloring hard anodized
9	Piston A	Aluminum alloy	Chromated
10	Piston B	Aluminum alloy	Chromated
11	Bumper B	Polyurethane	
12	Magnet	Magnetic material	
13	Bumper bolt	Carbon steel	Nickel plated
14	Hexagon nut	Carbon steel	Nickel plated
15	Bumper	Polyurethane	
16	Hexagon socket head cap screw	Chromium steel	Nickel plated
17	Hexagon socket head set screw	Chromium steel	Nickel plated
18	Snap ring	Stainless steel	Nickel plated
19	Steel ball	Stainless steel	Nickel plated
20	Piston seal	NBR	
21	Rod seal	NBR	
22	O-ring	NBR	
23	O-ring	NBR	
24	Cushion needle	Stainless steel	
25	Check seal retainer	Copper alloy	
26	Check seal	NBR	
27	Needle gasket	NBR	
28	Check gasket	NBR	

Compact Type
CXSM

Standard Type
CXSL

With Air Cushion
CXSM

With End Lock
CXSL

Dual-Double-Rod Type
CXSMW

Auto Switches

Made to Order

Precautions

Series CXS

Dimensions: $\phi 20$

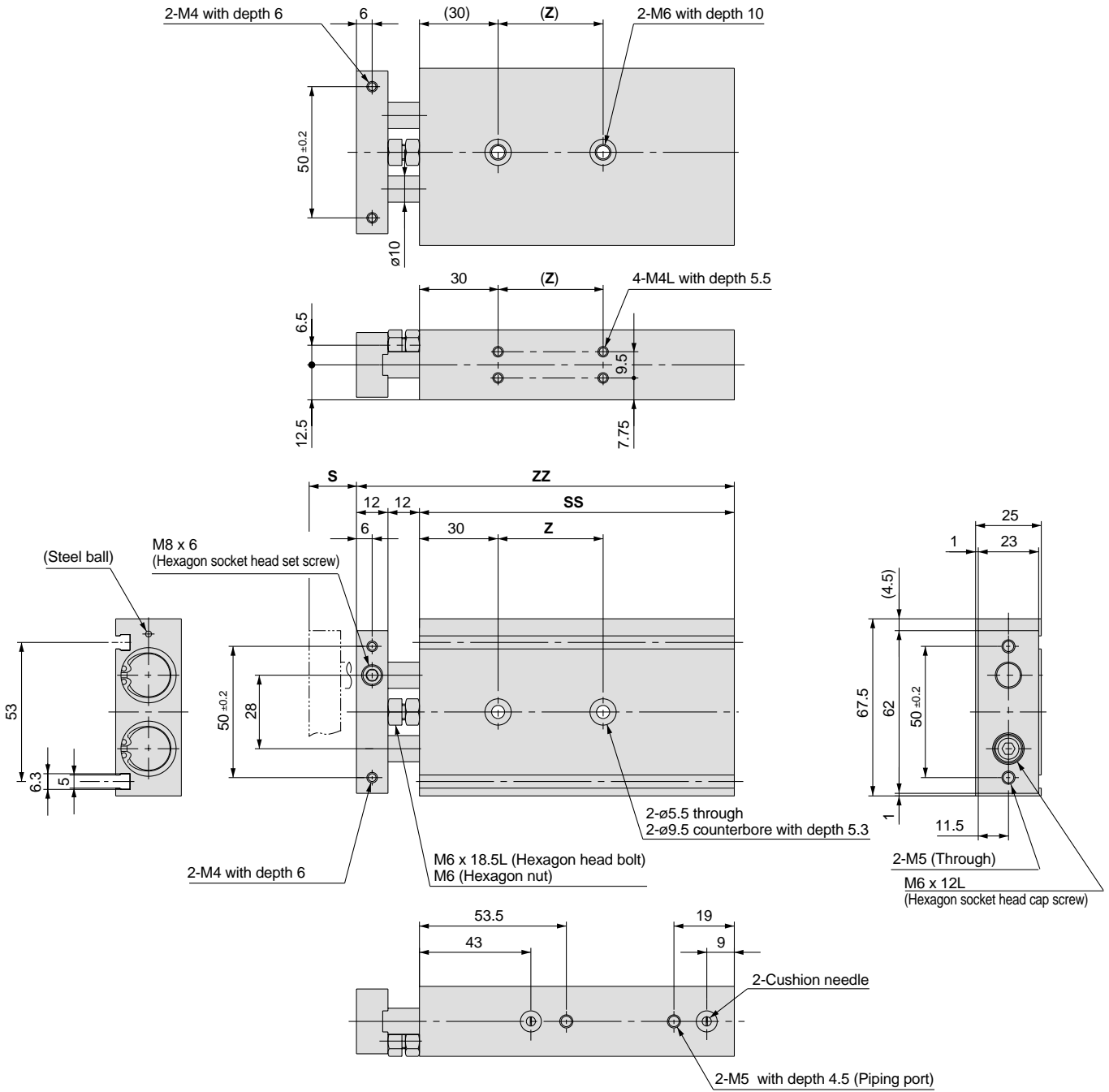

Part no.	S	SS	ZZ	Z
CXS□20- 20A	20	92	116	30
CXS□20- 25A	25	97	121	
CXS□20- 30A	30	102	126	
CXS□20- 35A	35	107	131	40
CXS□20- 40A	40	112	136	
CXS□20- 45A	45	117	141	
CXS□20- 50A	50	122	146	60
CXS□20- 60A	60	132	156	
CXS□20- 70A	70	142	166	
CXS□20- 75A	75	147	171	60
CXS□20- 80A	80	152	176	
CXS□20- 90A	90	162	186	
CXS□20-100A	100	172	196	

Dimensions: $\phi 25$

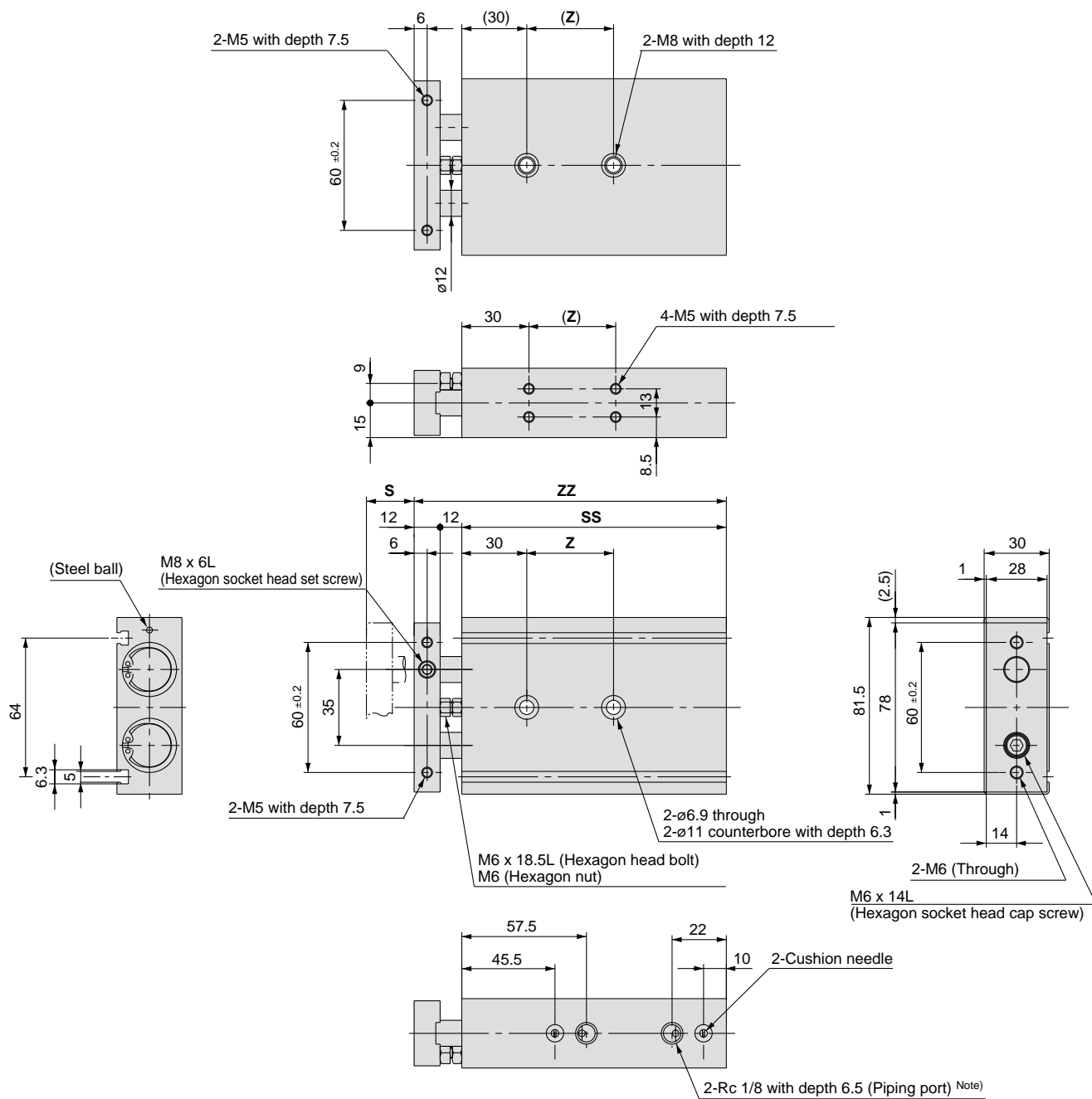

Part no.	S	SS	ZZ	Z
CXS□25- 25A	25	100	124	30
CXS□25- 30A	30	105	129	40
CXS□25- 35A	35	110	134	
CXS□25- 40A	40	115	139	
CXS□25- 45A	45	120	144	
CXS□25- 50A	50	125	149	
CXS□25- 60A	60	135	159	60
CXS□25- 70A	70	145	169	
CXS□25- 75A	75	150	174	
CXS□25- 80A	80	155	179	
CXS□25- 90A	90	165	189	
CXS□25-100A	100	175	199	

Note) For port threads TN and TF, only the piping port type varies.

Series CXS

Dimensions: $\varnothing 32$

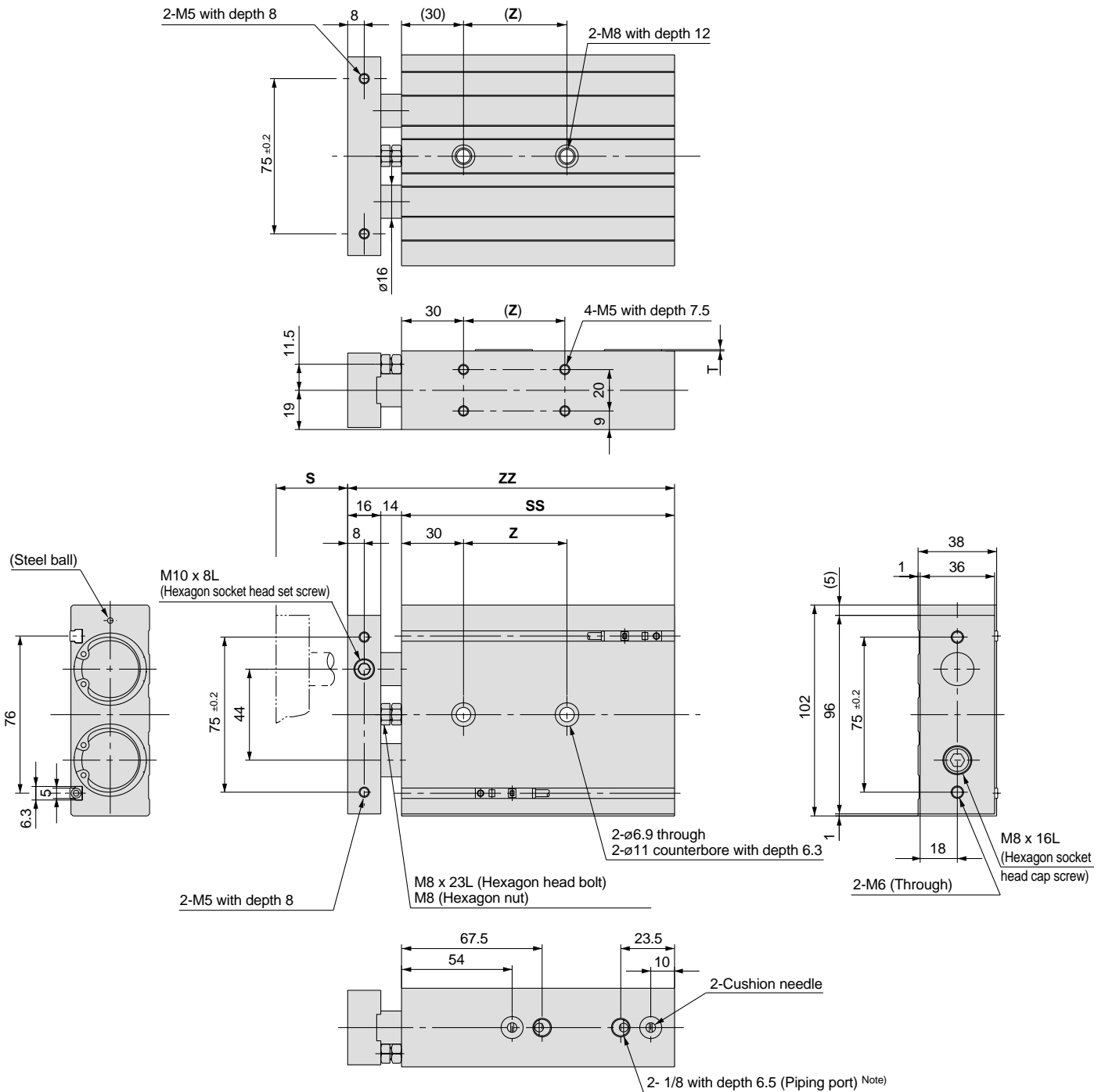

Part no.	S	SS	ZZ	Z
CXS□32- 25A	25	112	142	40
CXS□32- 30A	30	117	147	50
CXS□32- 35A	35	122	152	
CXS□32- 40A	40	127	157	
CXS□32- 45A	45	132	162	70
CXS□32- 50A	50	137	167	
CXS□32- 60A	60	147	177	
CXS□32- 70A	70	157	187	70
CXS□32- 75A	75	162	192	
CXS□32- 80A	80	167	197	
CXS□32- 90A	90	177	207	
CXS□32-100A	100	187	217	

Note) For port threads TN and TF, only the piping port type varies.

Auto Switch Proper Mounting Positions for Stroke End Detection

Electrical entry direction: Inward

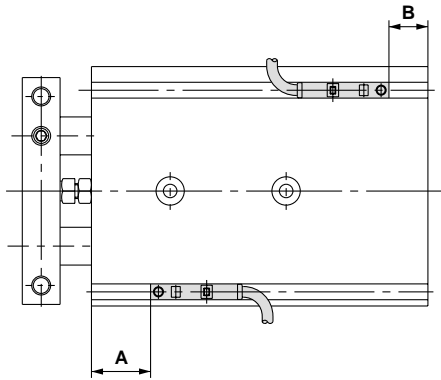

Electrical entry direction: Outward

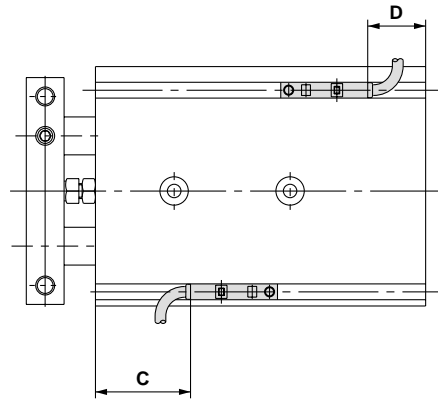

Bore size (mm)	A	B	D-Z7, D-Z8, D-Y7□W D-Y5□, D-Y7□		D-Y6□, D-Y7□V D-Y7□WV		D-Y7BAL	
			C	D	C	D	C	D
20	40.5	6.5	36.5 (35)	2.5 (1)	38.5	4	30.5	-3.5
25	42	8	38 (36.5)	4 (2.5)	40	5.5	32	-2
32	52.5	9.5	48.5 (47)	5.5 (4)	50.5	7	42.5	-0.5

Auto switch mounting and mounting dimensions are same as those for the standard type. Refer to page 18.

Compact Type
CXSJ

Standard Type
CXS

With Air Cushion
CXS

With End Lock
CXS

Dual-Double-Rod Type
CXS_W

Auto Switches

Made to Order

Precautions

Dual-Rod Cylinder with Rear End Lock

Series CXS

∅6, ∅10, ∅15, ∅20, ∅25, ∅32

How to Order

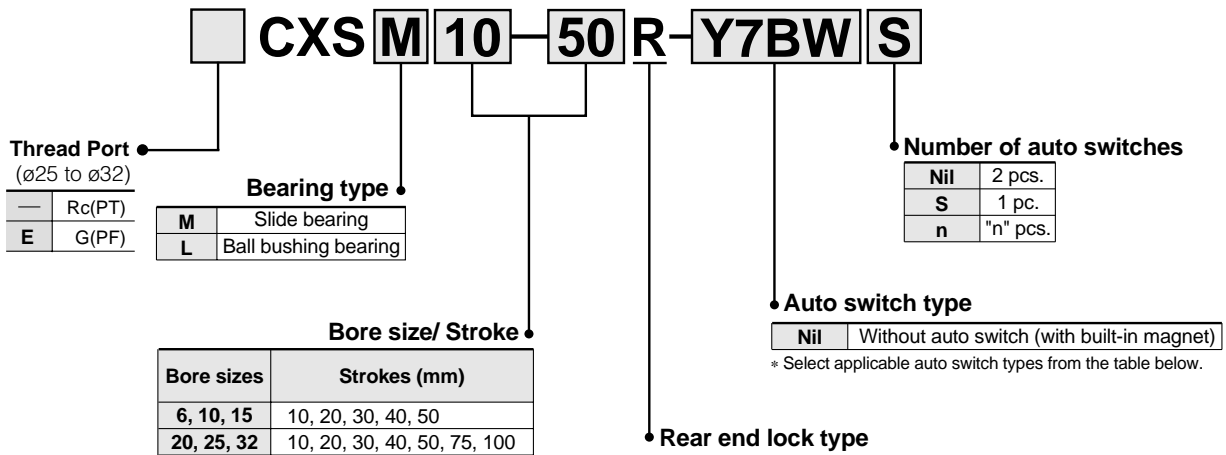

Applicable auto switches: Refer to pages 40 through 49 for detailed auto switch specifications.

Type	Special function	Electrical entry	Indicator light	Wiring (output)	Load voltage			Auto switch type		Lead wire length (m)*			Applicable loads	
					DC	AC		Electrical entry direction		0.5 (Nil)	3 (L)	5 (Z)		
								Perpendicular	In-line					
Reed switch	—	Grommet	Yes	3-wire	—	5V	—	—	Z76	●	●	—	IC circuit	—
				2-wire	24V	12V	100V	—	Z73	●	●	●	—	Relay PLC
			No			5V, 12V	100V or less	—	Z80	●	●	—	IC circuit	
Solid state switch	—	Grommet	Yes	3-wire (NPN)	24V	5V, 12V	—	Y69A	Y59A	●	●	○	IC circuit	Relay PLC
				3-wire (PNP)				Y7PV	Y7P	●	●	○	IC circuit	
				2-wire				Y69B	Y59B	●	●	○	—	
	Diagnostic indication (2-colour display)			3-wire (NPN)	5V, 12V	Y7NWV	Y7NW	●	●	○	IC circuit			
				3-wire (PNP)		Y7PWV	Y7PW	●	●	○	IC circuit			
	Water-resistant (2-colour display)			2-wire	12V	Y7BWV	Y7BW	●	●	○	—			
				—	—	—	Y7BA	—	●	○	—			

* Lead wire length symbols: 0.5m Nil (Example) Y59A
 3m L Y59AL
 5m Z Y59AZ

Note) Solid state switches marked "○" are produced upon receipt of order.



⚠ Specific Product Precautions

- Be sure to read before handling.
- Refer to pages 64 through 70 for Safety Instructions, Actuator Precautions, and Auto Switch Precautions.

Mounting

⚠ Caution

Mounting and adjusting

- Release the lock when mounting and adjusting the cylinder. An attempt to mount or adjust a cylinder while it is locked can damage the lock.
- Never adjust the retracting stroke using a bumper bolt or external stopper. The lock will not function.

Releasing the lock

- Do not release the lock while a load is applied to the lock. This will cause a sudden, erratic movement of the cylinder, and create a dangerous condition.

Control circuit

- To control the end lock cylinder, use a 2-position 4-/5-port solenoid valve. Avoid using these valves along with a 3-position solenoid valve (especially a closed-centre metal seal type).
- Be sure to supply air and apply back pressure to the retracted end before operation. If air is supplied to the extended end while there is no air inside of the cylinder, it will cause a sudden, erratic movement of the cylinder, and create a dangerous condition.

Manual Release

Manual release (Non-locking type)

- Insert the manual lever and screw it into the lock holder assembly.

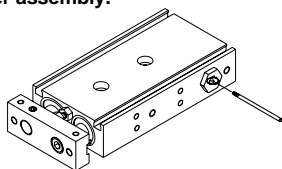

- To unlock, pull the manual lever in the direction of the arrow. Release the manual lever to return the cylinder to a ready-to-lock state.

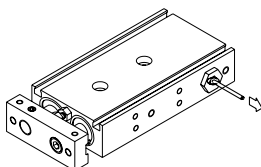

- The manual lever (ø1.6 x 35, tip part: M1.6 x 0.35 x 3) is included with the cylinder. If additional manual levers are required, use the following part number to place an order: CXS06-48BK2777 (for all series)

Specifications

Bore size (mm)	6	10	15	20	25	32
Fluid	Air (Non-lube)					
Proof pressure	1.05MPa					
Maximum operating pressure	0.7MPa					
Minimum operating pressure	0.3MPa					
Ambient and fluid temperature	-10° to 60°C (with no freezing)					
Piston speed ^{Note)}	30 to 300mm/s	30 to 800mm/s	30 to 700mm/s	30 to 600mm/s		
Cushion	Bumper is standard on both sides					
Port size	M5				1/8	
Bearing type	Slide bearing, Ball bushing bearing (Same dimensions for both)					

Note) The maximum piston speed shown in the table above is for extension.
The maximum piston speed for retraction is approximately 70% that of extension.

Lock Specifications

Lock specification	Rear End Lock					
Bore size (mm)	6	10	15	20	25	32
Maximum holding force (N)	14.7	39.2	98.1	157	235	382
Manual release	Non-locking type					

Standard Strokes

Model	Standard strokes (mm)
CXS□ 6	10, 20, 30, 40, 50
CXS□10	
CXS□15	
CXS□20	10, 20, 30, 40, 50, 75, 100
CXS□25	
CXS□32	

* Long strokes (i.e., strokes beyond the standard stroke range) are available as a special order and processed accordingly.

Theoretical Output

Model	Rod size (mm)	Operating direction	Piston area (mm ²)	Operating pressure (MPa)							
				0.1	0.15	0.2	0.3	0.4	0.5	0.6	0.7
CXS□ 6	4	OUT	56	—	8.4	11.2	16.8	22.4	28.0	33.6	39.2
		IN	31	—	4.6	6.2	9.3	12.4	15.5	18.6	21.7
CXS□10	6	OUT	157	15.7	—	31.4	47.1	62.8	78.5	94.2	110
		IN	100	10.0	—	20.0	30.0	40.0	50.0	60.0	70.0
CXS□15	8	OUT	353	35.3	—	70.6	106	141	177	212	247
		IN	252	25.2	—	50.4	75.6	101	126	151	176
CXS□20	10	OUT	628	62.8	—	126	188	251	314	377	440
		IN	471	47.1	—	94.2	141	188	236	283	330
CXS□25	12	OUT	982	98.2	—	196	295	393	491	589	687
		IN	756	75.6	—	151	227	302	378	454	529
CXS□32	16	OUT	1608	161	—	322	482	643	804	965	1126
		IN	1206	121	—	241	362	482	603	724	844

Note) Theoretical output (N) = Pressure (MPa) x Piston area (mm²)

Weights

Model	Standard strokes (mm)						
	10	20	30	40	50	75	100
CXSM6-□R	0.105	0.12	0.135	0.15	0.165	—	—
CXSL6-□R	0.105	0.12	0.135	0.15	0.165	—	—
CXSM10-□R	0.18	0.2	0.225	0.25	0.27	—	—
CXSL10-□R	0.18	0.2	0.225	0.25	0.27	—	—
CXSM15-□R	0.3	0.33	0.355	0.38	0.41	—	—
CXSL15-□R	0.32	0.35	0.375	0.4	0.43	—	—
CXSM20-□R	0.465	0.5	0.54	0.58	0.62	0.715	0.815
CXSL20-□R	0.485	0.52	0.56	0.60	0.64	0.735	0.835
CXSM25-□R	0.72	0.76	0.8	0.84	0.88	0.98	1.08
CXSL25-□R	0.73	0.77	0.81	0.85	0.89	0.99	1.09
CXSM32-□R	1.33	1.43	1.53	1.62	1.72	1.96	2.2
CXSL32-□R	1.35	1.45	1.55	1.64	1.74	1.98	2.22

Series CXS

Construction: Slide Bearing

CXSM6

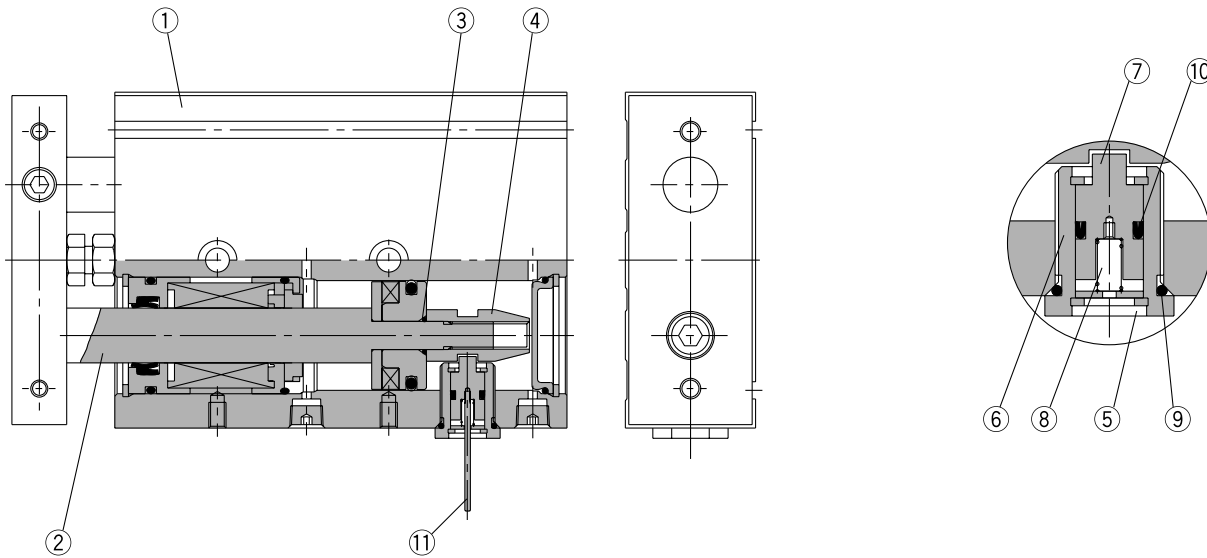

Parts list

No.	Description	Material	Note
1	Housing	Aluminum alloy	Hard anodized
2	Piston rod B	Carbon steel	Hard chrome plated
3	O-ring	NBR	
4	Lock rod	Special steel	
5	Snap ring	Special steel	
6	Lock holder	Aluminum alloy	
7	Lock pin	Special steel	
8	Lock spring	Piano wire	
9	O-ring	NBR	
10	Lock seal	NBR	
11	Manual lever	Special steel	

* Parts other than those listed above are same as the standard type.

Replacement parts: Seal kits

Bore size (mm)	Seal kit no.	Kit components
6	CXSRM6-PS	Includes the kit components of the seal kit featured on page 14 plus items 9 and 10 from the parts list above.
	CXSRL6APS	
10	CXSRM10-PS	
	CXSRL10APS	
15	CXSRM15-PS	
	CXSRL15APS	
20	CXSRM20-PS	
	CXSRL20APS	
25	CXSRM25-PS	
	CXSRL25APS	
32	CXSRM32-PS	
	CXSRL32APS	

* Seal kits consist of the seal kits featured on page 14 plus items 9 and 10 from the above parts list, and can be ordered by using the seal kit number corresponding to each bore size.

Dimensions: $\phi 6$, $\phi 10$, $\phi 15$

CXS□6-□R

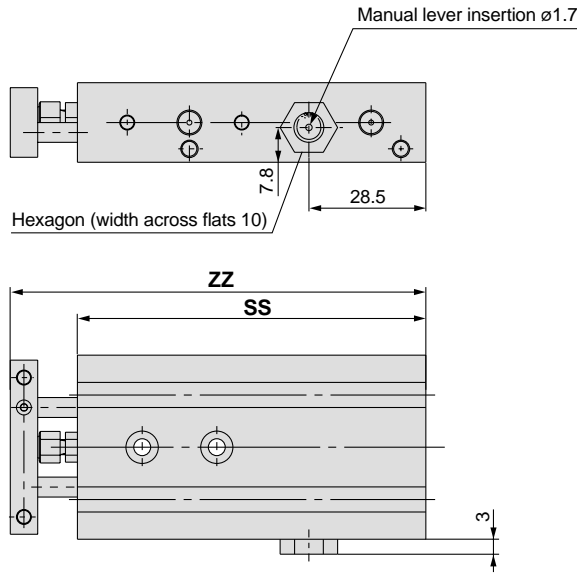

Model	SS	ZZ
CXS□6-10R	75	88.5
CXS□6-20R	85	98.5
CXS□6-30R	95	108.5
CXS□6-40R	105	118.5
CXS□6-50R	115	128.5

* Dimensions other than those listed above are the same as for the standard type.

CXS□¹⁰₁₅-□R

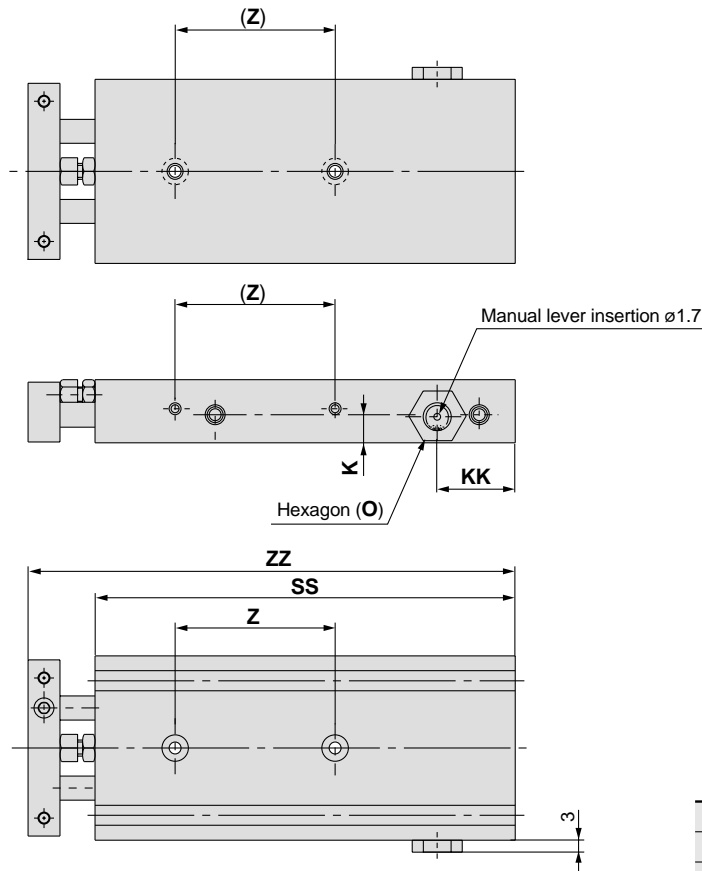

Model	K	O
CXS□10-□R	6.5	Width across flats 12
CXS□15-□R	8.5	Width across flats 13

Model	Symbol Stroke	KK					SS					Z					ZZ					
		10	20	30	40	50	10	20	30	40	50	10	20	30	40	50	10	20	30	40	50	
CXS□10-□R		19.5		24.5			80	90	100	115	125	30	40		50			97	107	117	132	142
CXS□15-□R		20.5					90	100	110	120	130	35			45		109	119	129	139	149	

* Dimensions other than those listed above are the same as for the standard type.

Series CXS

Dimensions: $\phi 20$, $\phi 25$, $\phi 32$

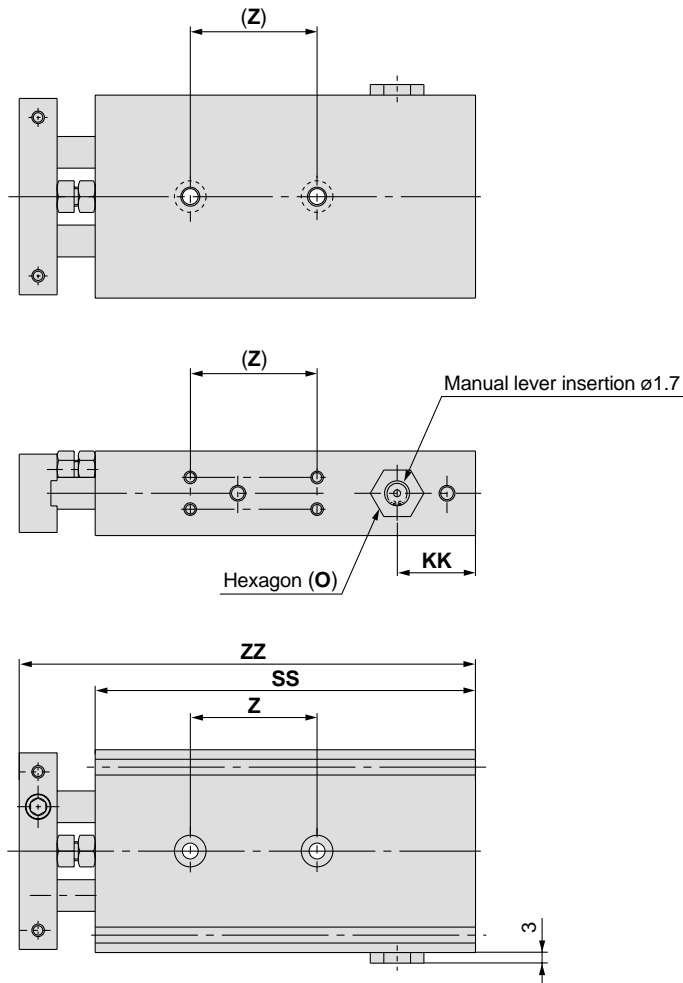

(mm)

Model	O
CXS□20-□R	Width across flats 13
CXS□25-□R	Width across flats 16
CXS□32-□R	Width across flats 19

(mm)

Model	Symbol Stroke	KK							SS							Z					ZZ						
		10	20	30	40	50	75	100	10	20	30	40	50	75	100	10	20	30	40	50	75	100	10	20	30	40	50
CXS□20-□R		22		27		22	100	110	120	130	140	170	190	40		60			80	124	134	144	154	164	194	214	
CXS□25-□R		24.5		29.5		24.5	107	117	132	142	147	172	197	40		60			80	131	141	156	166	171	196	221	
CXS□32-□R		29		34		49	122	132	142	152	162	192	232	50		70		90		152	162	172	182	192	222	262	

* Dimensions other than those listed above are the same as for the standard type.

Auto Switch Proper Mounting Positions for Stroke End Detection

Electrical entry direction: Inward

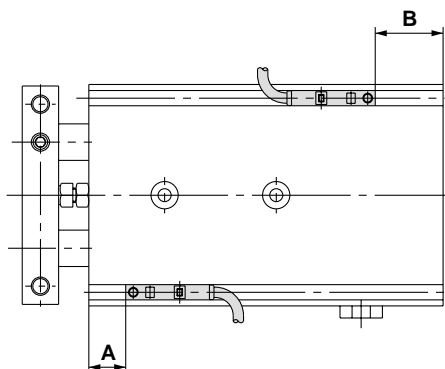

Electrical entry direction: Outward

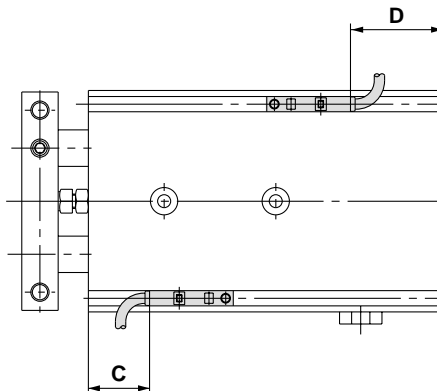

Bore size (mm)	A	B	D-Z7, D-Z8, D-Y7□W D-Y5□, D-Y7□		D-Y6□, D-Y7□V D-Y7□WV		D-Y7BAL	
			C	D	C	D	C	D
6	15.5	24.5	11.5 (10)	20.5 (19)	13	22	5.5	14.5
10	22.5	22.5	18.5 (17)	18.5 (17)	20	20	12.5	12.5
15	30.5	24.5	26.5 (25)	20.5 (19)	28	22	20.5	14.5
20	38	27	34 (32.5)	23 (21.5)	36	24.5	28	17
25	38	34	34 (32.5)	30 (28.5)	36	31.5	28	24
32	48	39	44 (42.5)	35 (33.5)	46	6.5	38	29

Auto switch mounting and mounting dimensions are same as those for the standard type. Refer to page 18.

Compact Type
CXSJ

Standard Type
CXS

With Air Cushion
CXS

With End Lock
CXS

Dual-Double-Rod Type
CXS_W

Auto Switches

Made to Order

Precautions

Dual-Double-Rod Cylinder

Series CXSW

ø6, ø10, ø15, ø20, ø25, ø32

How to Order

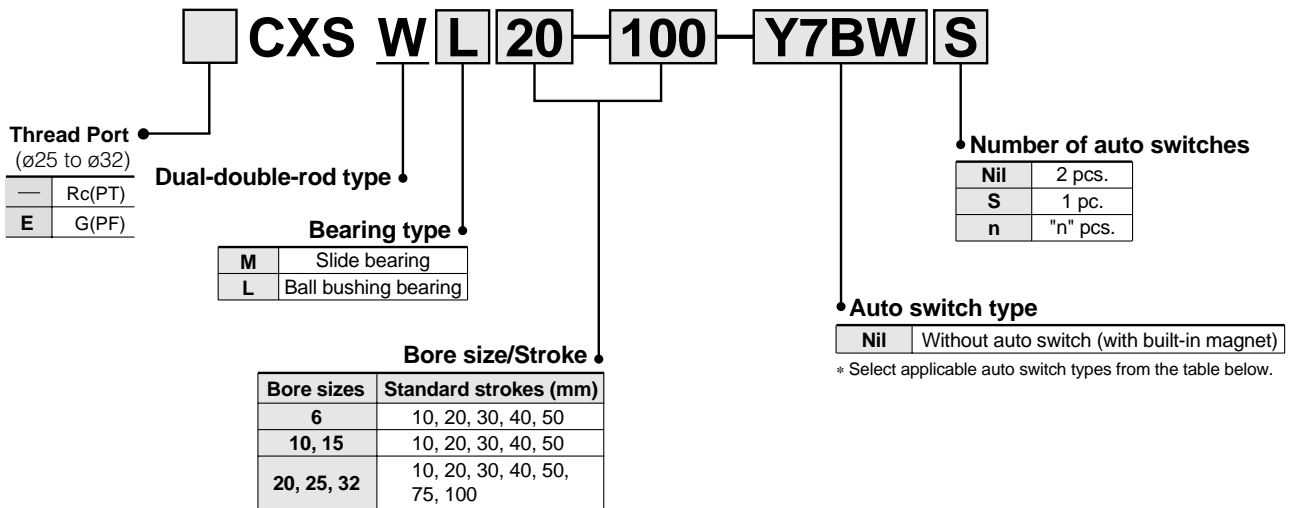

Applicable auto switches: Refer to pages 40 through 49 for detailed auto switch specifications.

Type	Special function	Electrical entry	Indicator light	Wiring (output)	Load voltage			Auto switch type		Lead wire length (m)*			Applicable loads	
					DC		AC	Electrical entry direction		0.5 (Nil)	3 (L)	5 (Z)		
					—	5V	—	Perpendicular	In-line	—	—	—	—	—
Reed switch	—	Grommet	Yes	3-wire	—	5V	—	—	Z76	●	●	—	IC circuit	—
				2-wire	24V	12V	100V	—	Z73	●	●	●	—	Relay, PLC
						5V, 12V	100V or less	—	Z80	●	●	—	IC circuit	
Solid state switch	—	Grommet	Yes	3-wire (NPN)	5V, 12V	—	Y69A	Y59A	●	●	○	IC circuit	Relay, PLC	
				3-wire (PNP)			Y7PV	Y7P	●	●	○			
				2-wire			12V	Y69B	Y59B	●	●			○
	Diagnostic indication (2-colour display)			24V	3-wire (NPN)	5V, 12V	—	Y7NWW	Y7NW	●	●	○		IC circuit
					3-wire (PNP)			Y7PWV	Y7PW	●	●	○		
	Water-resistant (2-colour display)			12V	Y7BWW	Y7BW	●	●	○	—				
					—	Y7BA	—	●	○	—				

* Lead wire length symbols: 0.5m Nil (Example) Y59A
 3m L Y59AL
 5m Z Y59AZ

Note) Solid state switches marked "○" are produced upon receipt of order.
 Y7BAL is not compatible with sizes ø10, ø15, and ø20. Please inquire separately.

Dual-Double-Rod Cylinder *Series CXSW*



Specifications

Bore size (mm)	6	10	15	20	25	32
Fluid	Air (non-lube)					
Proof pressure	1.05MPa					
Maximum operating pressure	0.7MPa					
Minimum operating pressure	0.15MPa			0.1MPa		
Ambient and fluid temperature	-10° to 60°C (with no freezing)					
Piston speed	50 to 500mm/s					
Cushion	Bumper is standard on both sides					
Stroke adjustable range	0 to -10mm compared to the standard stroke (Extended end: 5mm; Retracted end: 5mm)					
Port size	M5				1/8	
Bearing type	Slide bearing, Ball bushing bearing (Same dimensions for both)					

Standard Strokes

Model	Standard strokes	Long stroke
CXSW□6	10, 20, 30, 40, 50	—
CXSW□10	10, 20, 30, 40, 50	75, 100, 125, 150
CXSW□15		
CXSW□20	10, 20, 30, 40, 50, 75, 100	125, 150, 175, 200
CXSW□25		
CXSW□32		

* Refer to "Made to Order" on page 51 for long strokes (i.e., strokes beyond the standard stroke range).

Theoretical Output

Model	Rod size (mm)	Piston area (mm ²)	Operating pressure (MPa)						
			0.1	0.2	0.3	0.4	0.5	0.6	0.7
CXSW□6	4	31	4.6	6.2	9.3	12.4	15.5	18.6	21.7
CXSW□10	6	100	10	20	30	40	50	60	70
CXSW□15	8	252	25.2	50.4	75.6	101	126	151	176
CXSW□20	10	471	47.1	94.2	141	188	236	283	330
CXSW□25	12	756	75.6	151	227	302	378	454	529
CXSW□32	16	1206	121	241	362	482	603	724	844

Note) Theoretical output (N) = Pressure (MPa) x Piston area (mm²)

Weights

Model	Standard stroke (mm)						
	10	20	30	40	50	75	100
CXSWM 6	0.11	0.13	0.14	0.16	0.17	—	—
CXSWL 6	0.12	0.13	0.15	0.16	0.18	—	—
CXSWM 10	0.24	0.26	0.28	0.30	0.32	0.37	0.42
CXSWL 10	0.25	0.27	0.29	0.31	0.33	0.38	0.43
CXSWM 15	0.43	0.45	0.48	0.51	0.54	0.61	0.68
CXSWL 15	0.47	0.50	0.52	0.55	0.58	0.65	0.72
CXSWM 20	0.71	0.74	0.78	0.82	0.85	0.95	1.04
CXSWL 20	0.75	0.79	0.82	0.86	0.90	0.99	1.08
CXSWM 25	1.06	1.11	1.17	1.22	1.28	1.41	1.55
CXSWL 25	1.07	1.12	1.18	1.23	1.29	1.42	1.56
CXSWM 32	2.04	2.12	2.21	2.29	2.38	2.59	2.81
CXSWL 32	2.06	2.15	2.23	2.32	2.41	2.62	2.83



Made to Order Specifications

Refer to pages 50 through 53 for Series CXSW Made to Order specifications.

Compact Type
CXSJ

Standard Type
CXS

With Air Cushion
CXS

With End Lock
CXS

Dual-Double-Rod Type
CXSW

Auto Switches

Made to Order

Precautions

Series CXSW

Operating Conditions

Maximum load weight

When the cylinder is mounted as shown in the diagrams below, the maximum load weight W should not exceed the values illustrated in the graph immediately following the diagrams.

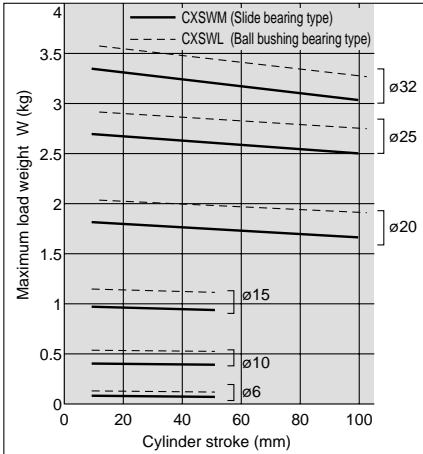
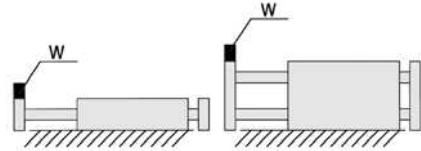

Note) Consult with SMC regarding the maximum load weight for long strokes depending on your sepecific usage conditions.

Non-rotating accuracy

Non-rotating accuracy θ° without a load should be less than or equal to the value provided in the table below as a guide.

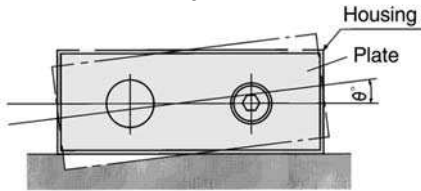

Bore size (mm)	6 to 32
CXSWM (Slide bearing)	±0.1°
CXSWL (Ball bushing bearing)	

Deflection at the plate end

An approximate plate-end deflection X without a load is shown in the graph below.

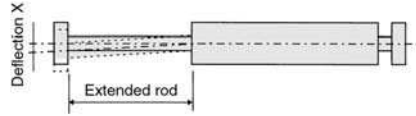

Bore size (mm)	6 to 32
CXSWM (Slide bearing)	±0.03mm
CXSWL (Ball bushing bearing)	

Allowable kinetic energy

Operate a vertically mounted cylinder with a load weight and cylinder speed not exceeding the ranges shown in the graph below. A horizontally mounted cylinder should also be operated with a load weight less than the ranges given in the graph at left.

Cylinder speed should be adjusted using a speed controller.

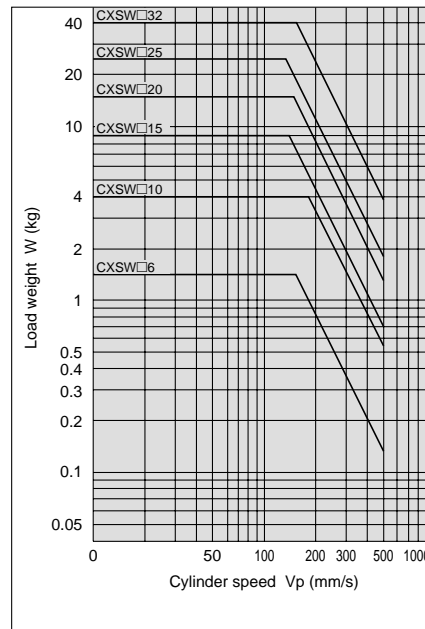

Construction

CXSWM Slide bearing

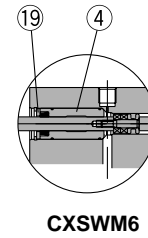
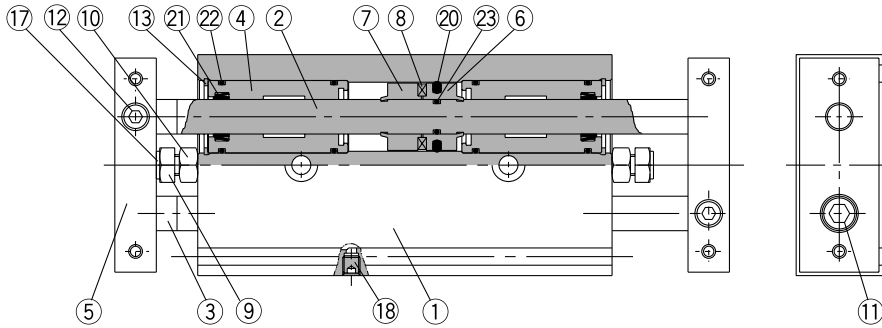

CXSWL Ball bushing bearing

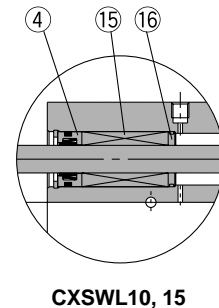
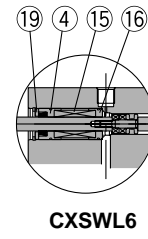
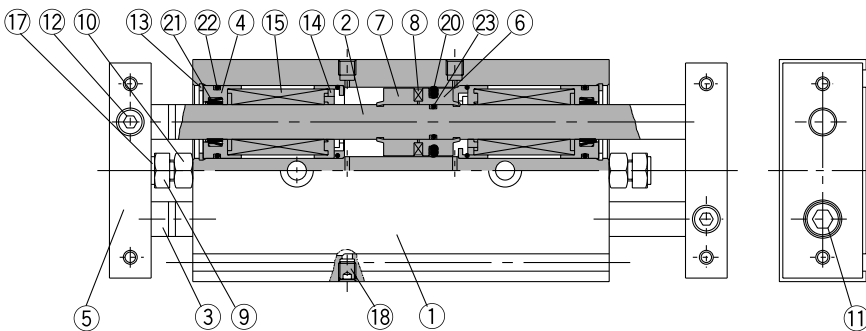

(Piston)

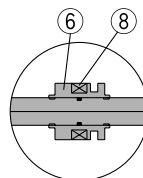
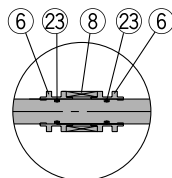
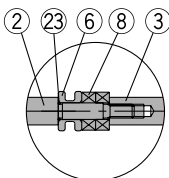

Parts list

No.	Description	Material	Note
1	Housing	Aluminum alloy	Hard anodized
2	Piston rod A	Carbon steel	Hard chrome plated
3	Piston rod B	Carbon steel	Hard chrome plated
4	Rod cover/Bearing	Aluminum alloy	
5	Plate	Aluminum alloy	Hard anodized
6	Piston A	Aluminum alloy	Chromated
7	Piston B	Aluminum alloy	Chromated
8	Magnet	Magnetic material	
9	Bumper bolt	Carbon steel	Nickel plated
10	Hexagon nut	Carbon steel	Nickel plated
11	Hexagon socket head cap screw	Chromium steel	Nickel plated
12	Hexagon socket head set screw	Chromium steel	Nickel plated

Note) Piston rod for CXSWL is quenched.

Replacement parts: Seal kits

Bore size (mm)	Seal kit no.	Kit components
6	CXSWM6-PS	Items 20 through 22 from the chart above.
	CXSWL6-PS	
10	CXSWM10-PS	
	CXSWL10APS	
15	CXSWM15-PS	
	CXSWL15APS	
20	CXSWM20-PS	
	CXSWL20APS	
25	CXSWM25-PS	
	CXSWL25APS	
32	CXSWM32-PS	
	CXSWL32APS	

Parts list

No.	Description	Material	Note
13	Snap ring	Special steel	Nickel plated
14	Bumper holder	Synthetic resin	
15	Ball bushing	—	
16	Bearing spacer	Synthetic resin	
17	Bumper	Polyurethane	
18	Plug	Chromium steel	Nickel plated
19	Seal retainer	Aluminum alloy	
20 [†]	Piston seal	NBR	
21 [†]	Rod seal	NBR	
22 [†]	O-ring	NBR	
23	O-ring	NBR	

* Seal kits consist of items 20 through 22, and can be ordered by using the seal kit number corresponding to each bore size. However for CXSWL15, there are two types of O-ring (22). For other sizes, one type of O-ring is available. For CXSWL6, aluminum alloy is used for 16.

Series CXSW

Dimensions: $\phi 6, \phi 10$

CXSW□6

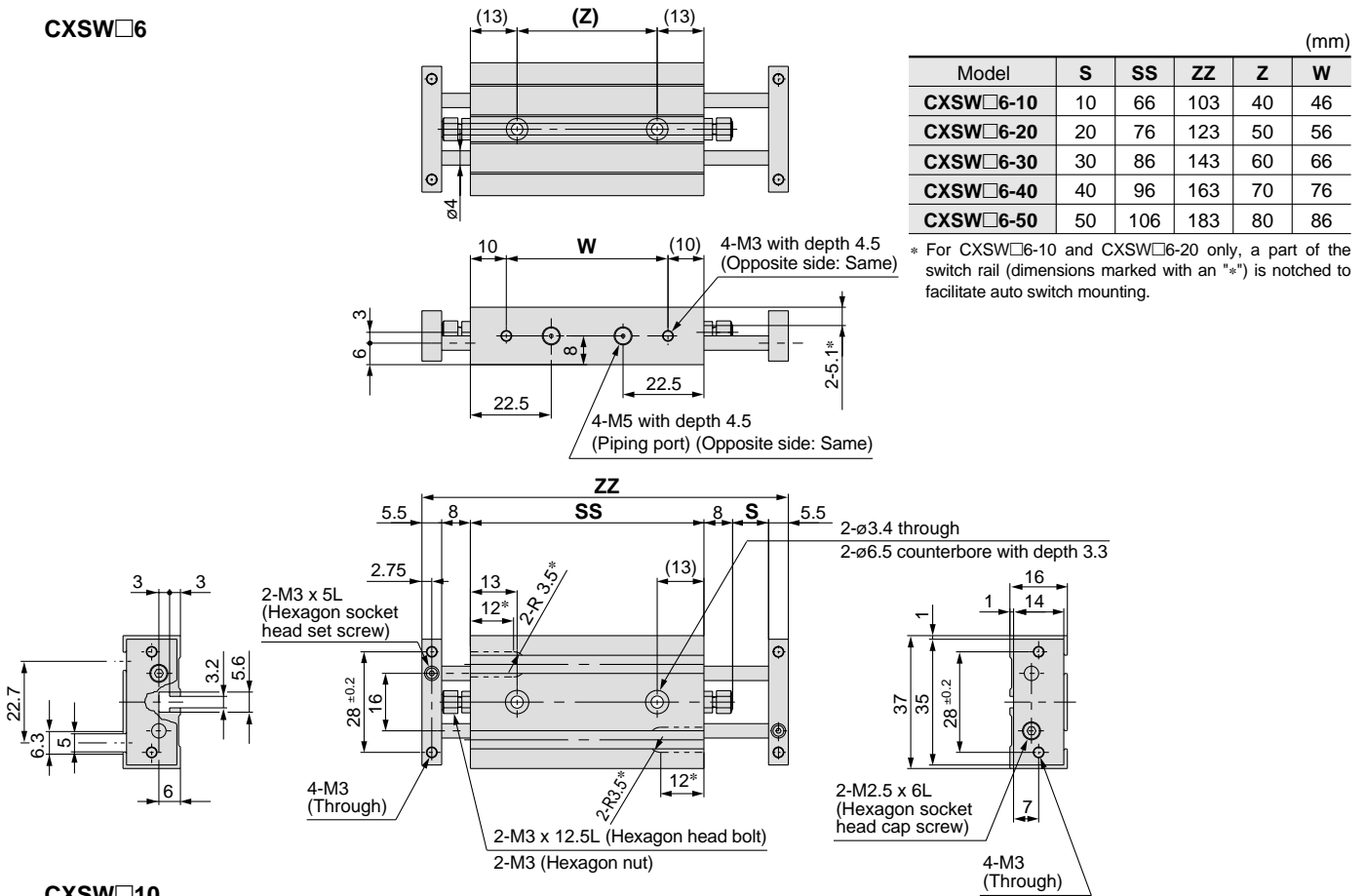

CXSW□10

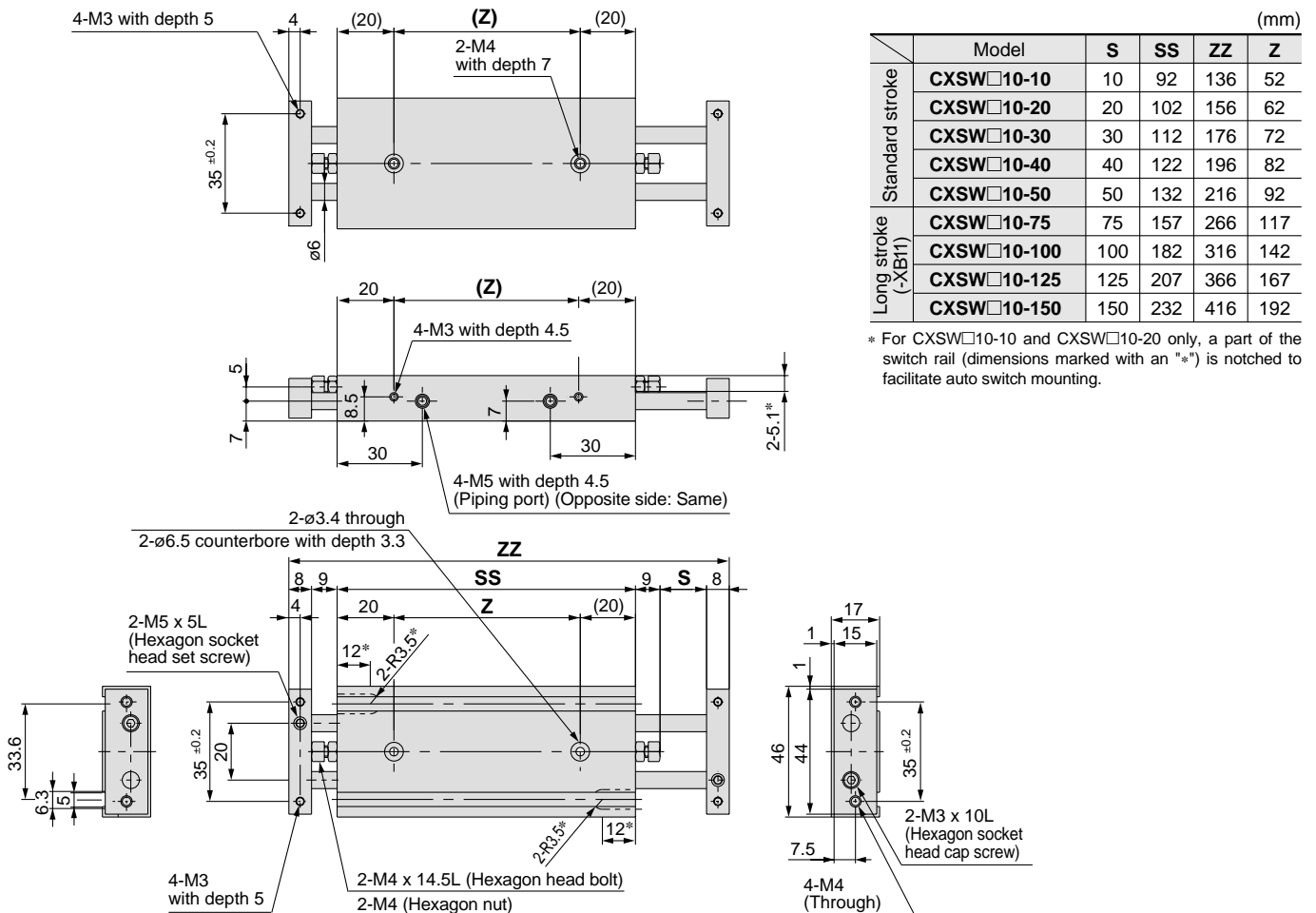

Dimensions: $\varnothing 15, \varnothing 20$

CXSW□15

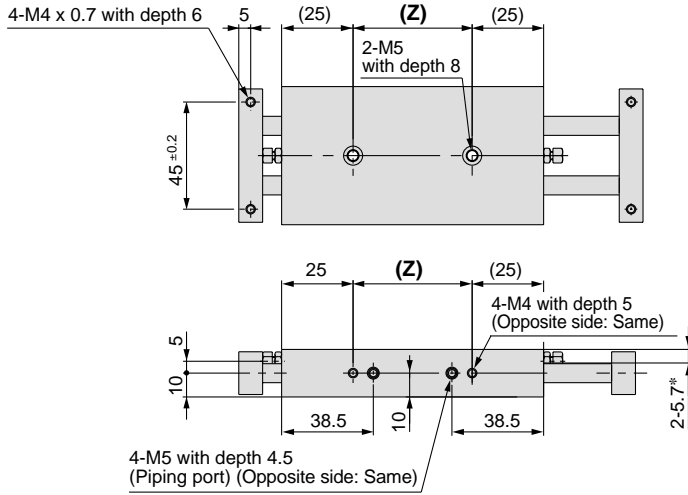

CXSW□20

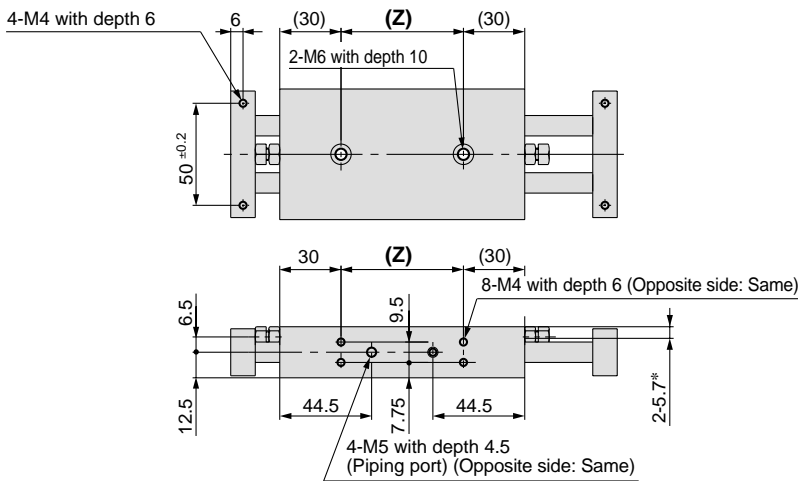

		(mm)				
		Model	S	SS	ZZ	Z
Standard stroke	CXSW□15-10	10	105	153	55	
	CXSW□15-20	20	115	173	65	
	CXSW□15-30	30	125	193	75	
	CXSW□15-40	40	135	213	85	
	CXSW□15-50	50	145	233	95	
Long stroke (~XB1f)	CXSW□15-75	75	170	283	120	
	CXSW□15-100	100	195	333	145	
	CXSW□15-125	125	220	383	170	
	CXSW□15-150	150	245	433	195	

* For CXSW□15-10 and CXSW□15-20 only, a part of the switch rail (dimensions marked with an "*") is notched to facilitate auto switch mounting.

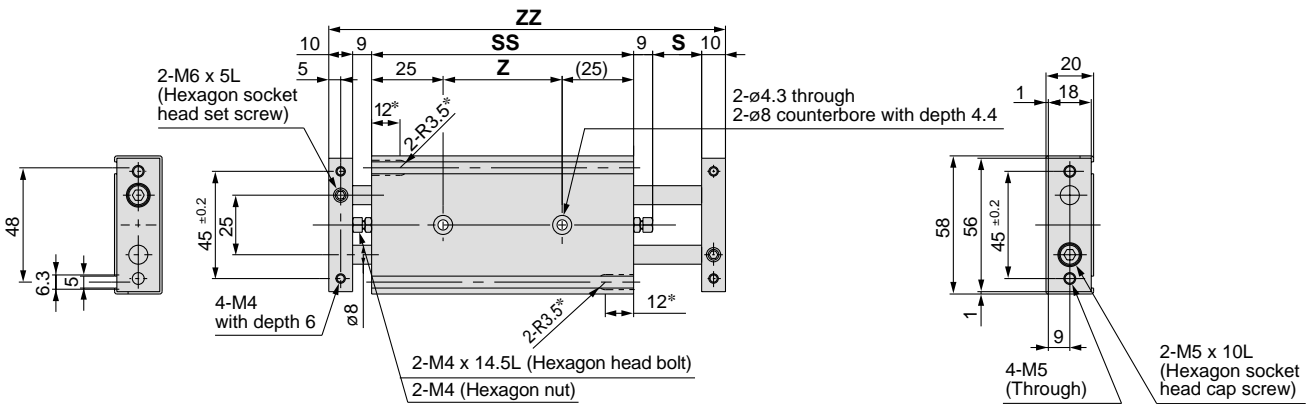

		(mm)				
		Model	S	SS	ZZ	Z
Standard stroke	CXSW□20-10	10	120	178	60	
	CXSW□20-20	20	130	198	70	
	CXSW□20-30	30	140	218	80	
	CXSW□20-40	40	150	238	90	
	CXSW□20-50	50	160	258	100	
	CXSW□20-75	75	185	308	125	
Long stroke (~XB1f)	CXSW□20-100	100	210	358	150	
	CXSW□20-125	125	235	408	175	
	CXSW□20-150	150	260	458	200	
	CXSW□20-175	175	285	508	225	
CXSW□20-200	200	310	558	250		

* For CXSW□20-10 only, a part of the switch rail (dimensions marked with an "*") is notched to facilitate auto switch mounting.

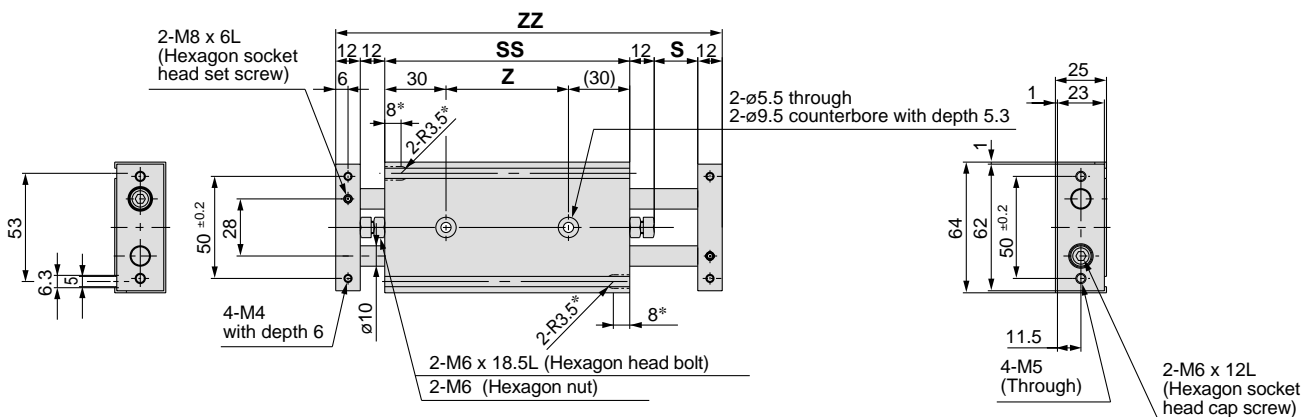

Series CXSW

Dimensions: $\varnothing 25$, $\varnothing 32$

CXSW□25

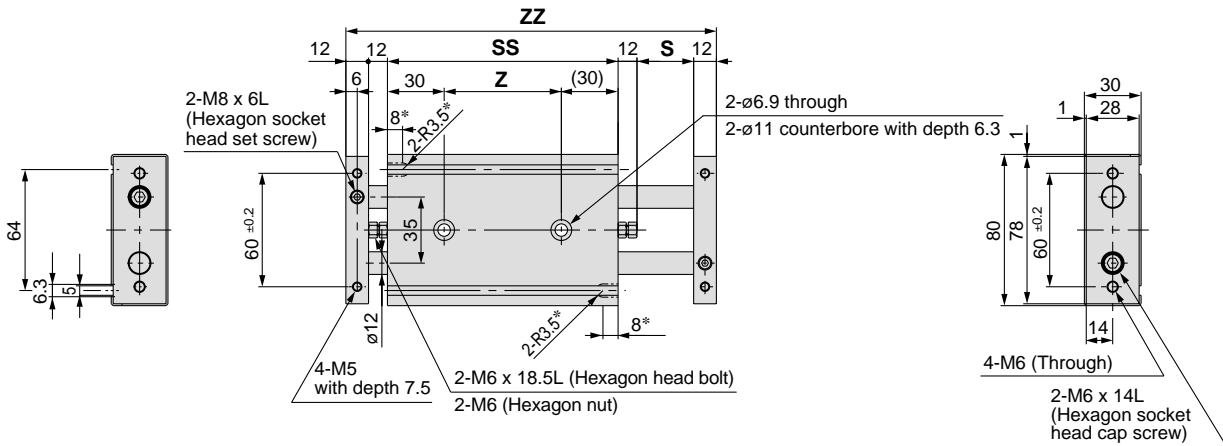
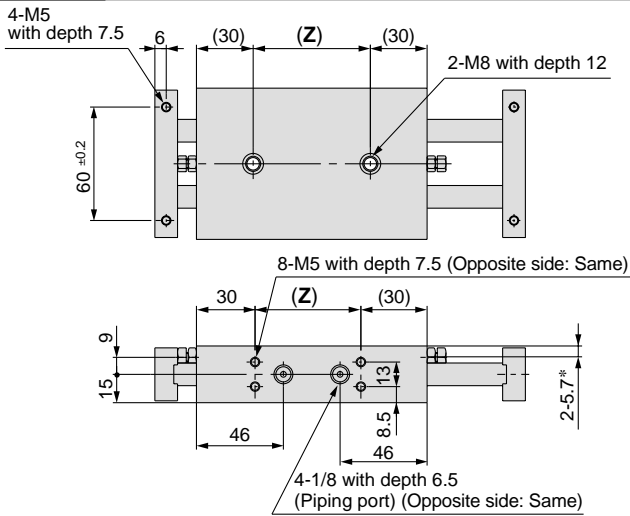

		(mm)				
		Model	S	SS	ZZ	Z
Standard stroke	CXSW□25-10	10	122	180	62	
	CXSW□25-20	20	132	200	72	
	CXSW□25-30	30	142	220	82	
	CXSW□25-40	40	152	240	92	
	CXSW□25-50	50	162	260	102	
	CXSW□25-75	75	187	310	127	
Long stroke (-XB11)	CXSW□25-125	125	237	410	177	
	CXSW□25-150	150	262	460	202	
	CXSW□25-175	175	287	510	227	
	CXSW□25-200	200	312	560	252	

* For CXSW□25-10 only, a part of the switch rail (dimensions marked with an "*" is) is notched to facilitate auto switch mounting.

CXSW□32

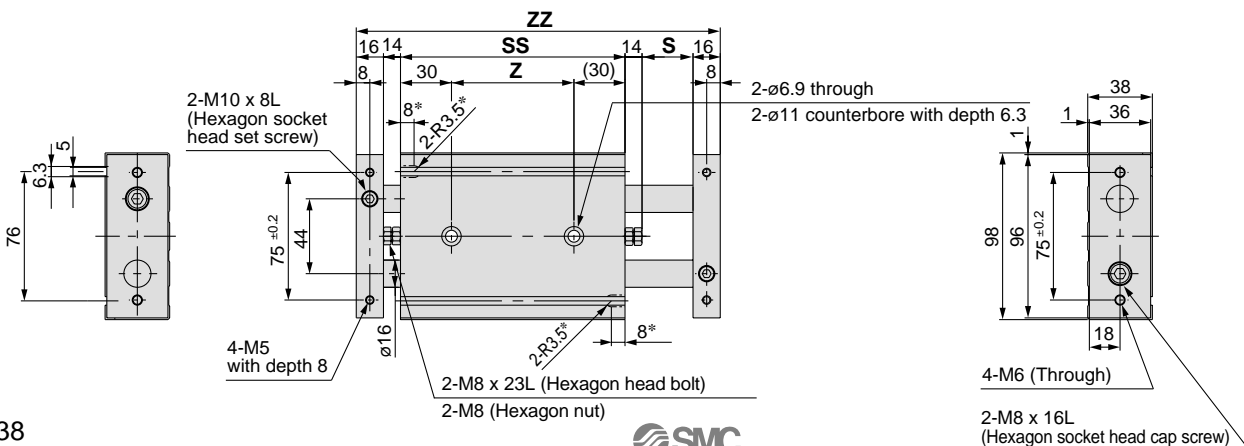
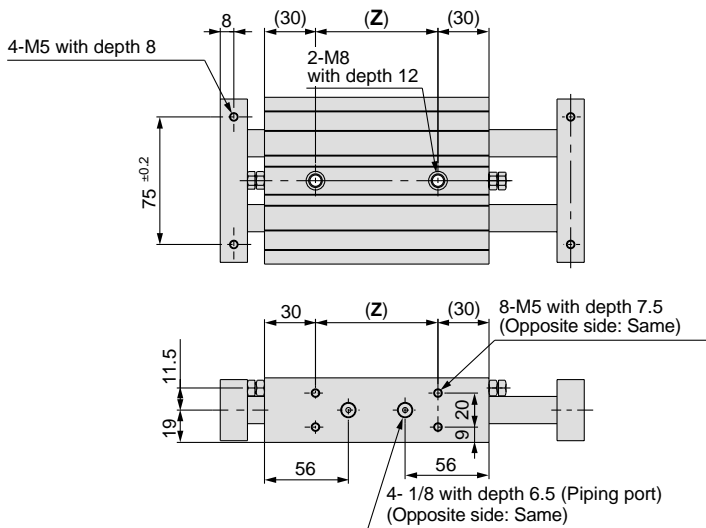

		(mm)				
		Model	S	SS	ZZ	Z
Standard stroke	CXSW□32-10	10	143	213	83	
	CXSW□32-20	20	153	233	93	
	CXSW□32-30	30	163	253	103	
	CXSW□32-40	40	173	273	113	
	CXSW□32-50	50	183	293	123	
	CXSW□32-75	75	208	343	148	
Long stroke (-XB11)	CXSW□32-100	100	233	393	173	
	CXSW□32-125	125	258	443	198	
	CXSW□32-150	150	283	493	223	
	CXSW□32-175	175	308	543	248	
CXSW□32-200	200	333	593	273		

* For CXSW□32-10 only, a part of the switch rail (dimensions marked with an "*" is) is notched to facilitate auto switch mounting.

Auto Switch Proper Mounting Positions for Stroke End Detection

Compact Type
CXSJ

Standard Type
CXS

With Air Cushion
CXS

With End Lock
CXS

Dual-Double Rod Type
CXSW

Auto Switches

Made to Order

Precautions

Electric entry direction: Inward

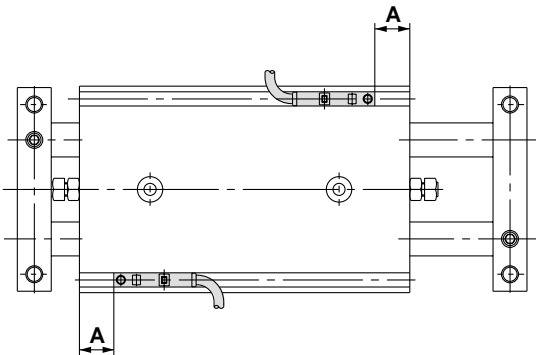

Electric entry direction: Outward

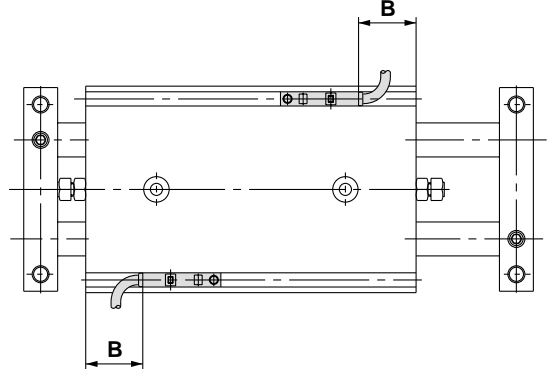

Bore size (mm)	A	D-Z7, D-Z8, D-Y7□W D-Y5□, D-Y7□	D-Y6□, D-Y7□V D-Y7□WV	D-Y7BAL
		B	B	B
6	13.8	9.8 (8.3)	11.3	3.8
10	28.5	24.5 (23)	26	—
15	35	31 (29.5)	32.5	—
20	42.5	38.5 (37)	40.5	—
25	43.5	39.5 (38)	41.5	33.5
32	54	50 (48.5)	52	44

Auto switch mounting and mounting dimensions are same as those for the standard type. Refer to page 18.

Auto Switch Common Specifications

Auto Switch Common Specifications

Type	Reed switch	Solid state switch
Leakage current	None	3-wire: 100μA or less; 2-wire: 0.8mA or less
Operating time	1.2ms	1ms or less
Impact resistance	300m/s ²	1000m/s ²
Insulation resistance	50MΩ or more at 500VDC (between lead wire and case)	
Withstand voltage	1500VAC for 1 min. (between lead wire and case)	1000VAC for 1 min. (between lead wire and case)
Ambient temperature	-10° to 60°C	
Enclosure	IEC529 standard IP67, JISC0920 watertight construction	

Lead Wire Lengths

Lead wire length indication

(Example)

D-F9P L

Lead wire length

Nil	0.5m
L	3m
Z	5m

- Notes) • Lead wire length Z (5m) applicable auto switches
 Solid state: All types are produced upon receipt of order.
 • To designate solid state switches with flexible specifications, add "-61" after the lead wire length.

(Example) D-F9PL-61

• Flexible specification

Note) For D-Y type, flexible specifications is standard, therefore it is not necessary to indicate "-61" when ordering.

Auto Switch Hysteresis

Hysteresis is the distance between the position at which piston movement operates an auto switch and the position at which movement in the opposite direction turns the switch off. This hysteresis is included in part (one side) of the operating range.

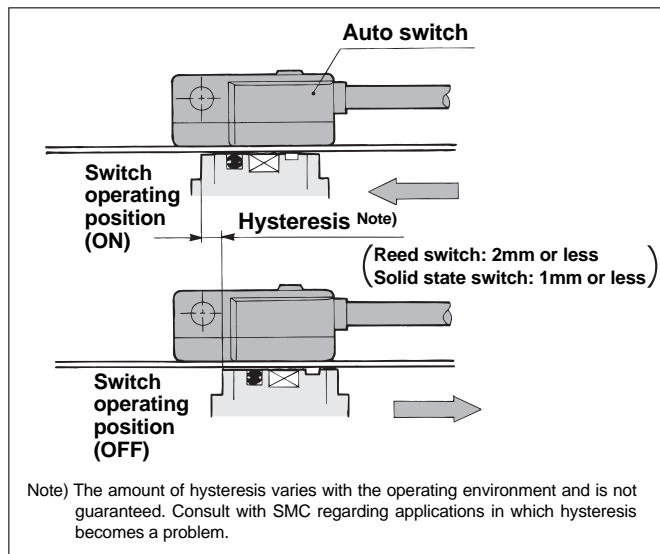

Contact Protection Box: CD-P11, CD-P12

D-A9, D-A9V□, D-Z7, and D-Z8 do not have built-in contact protection circuits.

A contact protection box should be used in any of the following conditions:

1. Operated load is an induction load.
2. The length of wiring to the load is 5m or more.
3. The load voltage is 100VAC.

Contact protection box specifications

Part no.	CD-P11		CD-P12
Load voltage	100VAC or less	200VAC	24VDC
Maximum load current	25mA	12.5mA	50mA

* Lead wire length — Switch connection side: 0.5m
 Load connection side: 0.5m



Internal circuits

Lead wire colours inside [] are those prior to conformity with IEC standards.

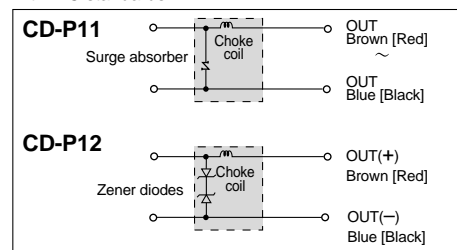

Dimensions

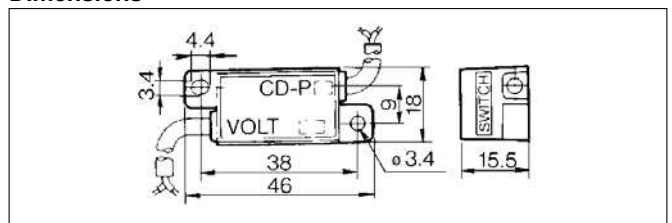

Connection for Contact Protection Box

To connect a switch unit to a contact protection box, connect the lead wire from the side of the contact protection box marked SWITCH to the lead wire coming out of the switch unit.

The switch unit should be kept as close as possible to the contact protection box with a lead wire that is no more than 1 meter in length.

Reed Switches: Direct Mounting Type D-A90(V), D-A93(V), D-A96(V)



Internal circuits

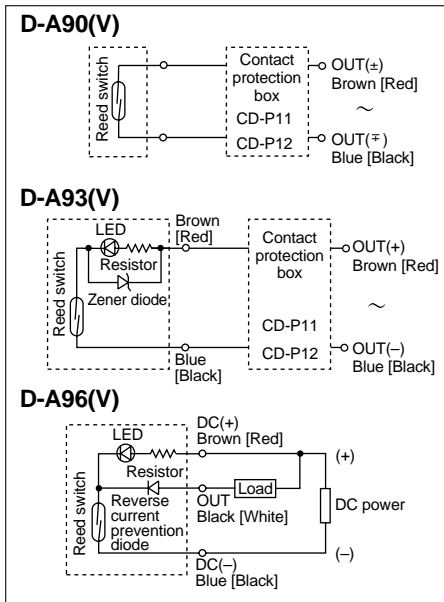

Specifications

D-A9□, D-A9□V						
Auto switch part no.	D-A90	D-A90V	D-A93	D-A93V	D-A96	D-A96V
Electrical entry direction	In-line	Perpendicular	In-line	Perpendicular	In-line	Perpendicular
Wiring type	2-wire			3-wire		
Applicable load	IC circuit, Relay, PLC		Relay, PLC		IC circuit	
Load voltage / Load current range and Max. load current	24V ^{AC} _{DC} or less/50mA 48V ^{AC} _{DC} or less/40mA 100V ^{AC} _{DC} or less/20mA		24VDC/5 to 40mA 100VAC/5 to 20mA		4 to 8VDC/20mA	
Contact protection circuit	Not available					
Internal voltage drop	0		2.4V or less (up to 20mA) 3V or less (up to 40mA)		0.8V or less	
Indicator light	None		Red LED lights when ON			

- Lead wire Oilproof heavy-duty vinyl cord: $\phi 2.7, 0.5m$
 D-A90 (V), D-A93 (V): 0.18mm² x 2 cores (Brown, Blue [Red, Black])
 D-A96 (V): 0.15mm² x 3 cores (Brown, Black, Blue [Red, White, Black])

Note) Refer to page 40 for auto switch common specifications and lead wire lengths.

Weights

Auto switch part no.	D-A90	D-A90V	D-A93	D-A93V	D-A96	D-A96V
Lead wire length: 0.5m	6	6	6	6	8	8
Lead wire length: 3m	30	30	30	30	41	41

Contact Protection Box

Type D-A9 switches do not have built-in contact protection circuits. Use a contact protection box with an induction load, when lead wires are 5 meters or longer, and with 100VAC.

Part no.	Voltage	Lead wire length
CD-P11	100VAC	Switch connection side: 0.5m Load connection side: 0.5m
CD-P12	24VDC	Load connection side: 0.5m

Since D-A90(V) type switches have no particular specified voltage below 100VAC, select a switch type based on the voltage being used.

Internal circuits

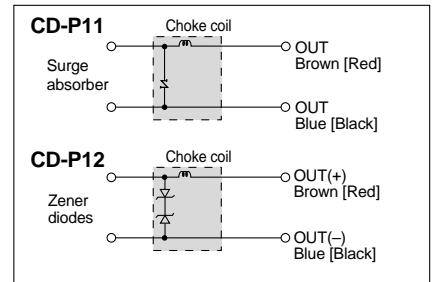

Dimensions

D-A90, D-A93, D-A96

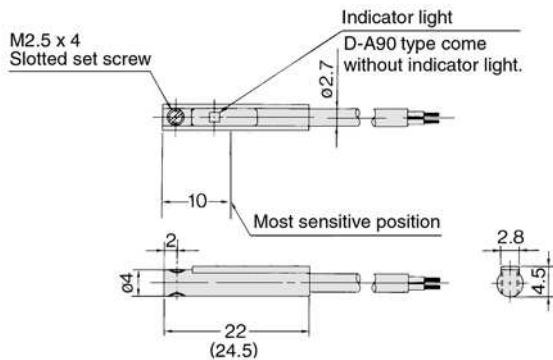

D-A90V, D-A93V, D-A96V

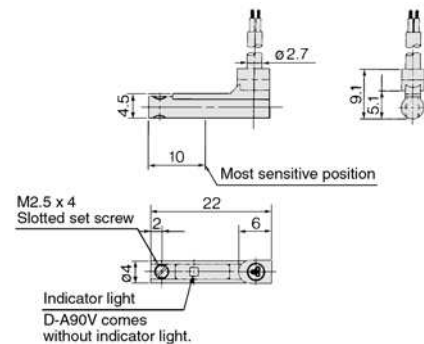

The dimension inside () is for D-A93.

Solid State Switches: Direct Mounting Type D-F9N(V), D-F9P(V), D-F9B(V)

Grommet



Specifications

D-F9□, D-F9□V (with indicator light)						
Auto switch part no.	D-F9N	D-F9NV	D-F9P	D-F9PV	D-F9B	D-F9BV
Electrical entry direction	In-line	Perpendicular	In-line	Perpendicular	In-line	Perpendicular
Wiring type	3-wire				2-wire	
Output type	NPN		PNP		—	
Applicable load	IC circuit, Relay, PLC				24VDC relay, PLC	
Power supply voltage	5, 12, 24VDC (4.5 to 28V)				—	
Current consumption	10mA or less				—	
Load voltage	28VDC or less		—		24VDC (10 to 28VDC)	
Load current	40mA or less		80mA or less		5 to 40mA	
Internal voltage drop	1.5V or less (0.8V or less at 10mA load current)		0.8V or less		4V or less	
Leakage current	100μA or less at 24VDC				0.8mA or less	
Indicator light	Red LED lights when ON					

- Lead wire Oilproof, heavy-duty vinyl cord: $\phi 2.7$, 0.5m
 D-F9N(V), D-F9P(V): 0.15mm² x 3 cores (Brown, Black, Blue [Red, White, Black])
 D-F9B(V): 0.18mm² x 2 cores (Brown, Blue [Red, Black])

Note) Refer to page 40 for auto switch common specifications and lead wire lengths.

Internal circuits

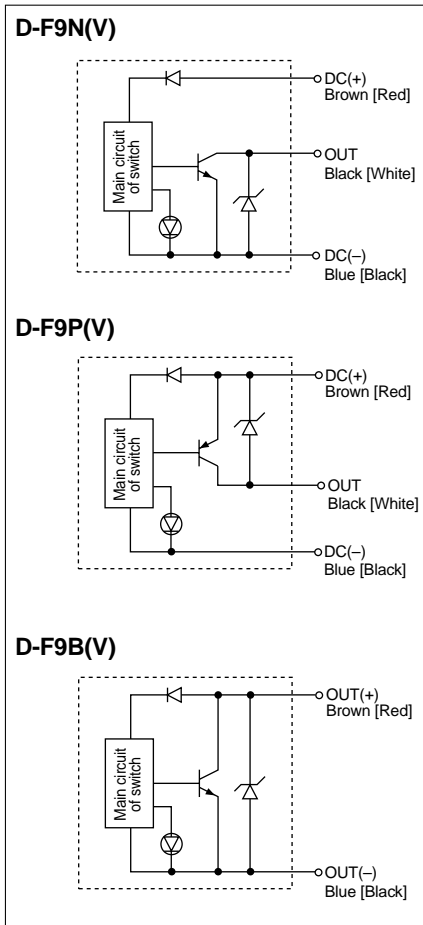

Weights

							(g)
Auto switch part no.	D-F9N	D-F9P	D-F9B	D-F9NV	D-F9PV	D-F9BV	
Lead wire length: 0.5m	7	7	6	7	7	6	
Lead wire length: 3m	37	37	31	37	37	31	

Dimensions

D-F9N, D-F9P, D-F9B

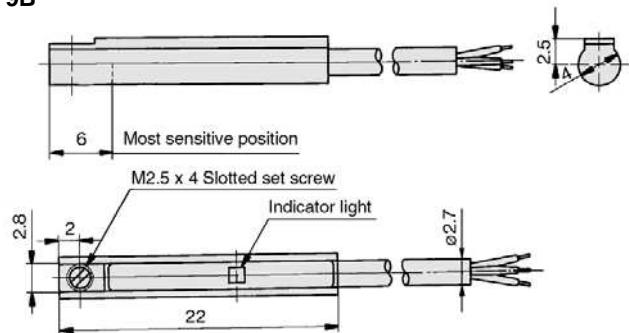

D-F9NV, DF9PV, D-F9BV

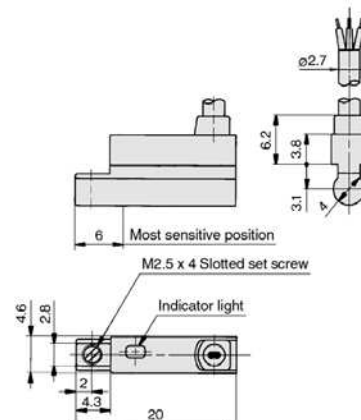

Solid State Switches with 2-Colour Display: Direct Mounting Type D-F9NW(V), D-F9PW(V), D-F9BW(V)

Compact Type
CXSJ

Standard Type
CXS

With Air Cushion
CXS

With End Lock
CXS

Dual-Rod Type
CXS

Auto Switches

Made to Order

Precautions

Grommet



Specifications

D-F9□W, D-F9□WV (with indicator light)						
Auto switch part no.	D-F9NW	D-F9NWV	D-F9PW	D-F9PWV	D-F9BW	D-F9BWV
Electrical entry direction	In-line	Perpendicular	In-line	Perpendicular	In-line	Perpendicular
Wiring type	3-wire			2-wire		
Output type	NPN		PNP		—	
Applicable load	IC circuit, Relay, PLC				24VDC relay, PLC	
Power supply voltage	5, 12, 24VDC (4.5 to 28V)				—	
Current consumption	10mA or less				—	
Load voltage	28VDC or less		—		24VDC (10 to 28VDC)	
Load current	40mA or less		80mA or less		5 to 40mA	
Internal voltage drop	1.5V or less (0.8V or less at 10mA load current)		0.8V or less		4V or less	
Leakage current	100μA or less at 24VDC				0.8mA or less	
Indicator light	Operating position Red LED lights up Optimum operating position ... Green LED lights up					

- Lead wire Oilproof, heavy-duty vinyl cord: $\phi 2.7, 0.5m$
D-F9NW(V), D-F9PW(V): 0.15mm² x 3 cores (Brown, Black, Blue [Red, White, Black])
D-F9BW(V): 0.18mm² x 2 cores (Brown, Blue [Red, Black])

Note) Refer to page 40 for auto switch common specifications and lead wire lengths.

Internal circuits

D-F9NW(V)

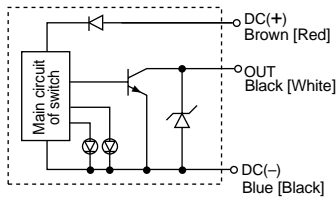

D-F9PW(V)

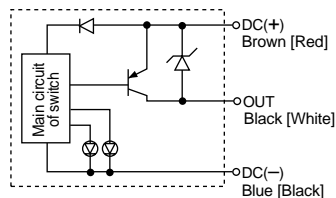

D-F9BW(V)

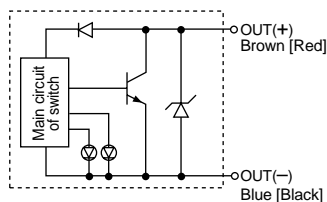

Indicator light

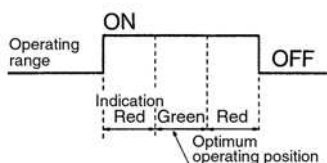

Weights

Auto switch part no.	D-F9NW	D-F9NWV	D-F9PW	D-F9PWV	D-F9BW	D-F9BWV
Lead wire length: 0.5m	7	7	7	7	7	7
Lead wire length: 3m	34	34	34	34	32	32

Dimensions

D-F9NW, D-F9PW, D-F9BW

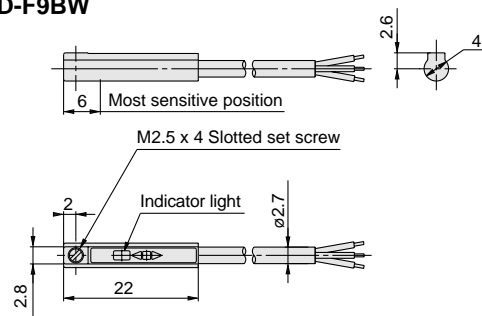

D-F9NWV, D-F9PWV, D-F9BWV

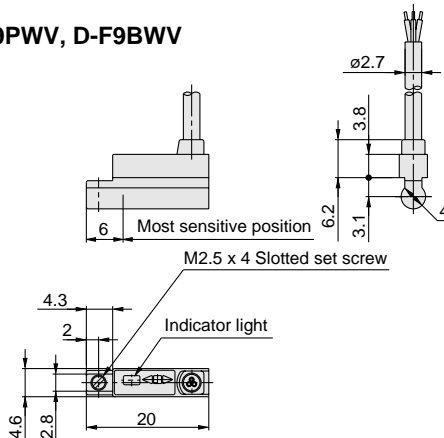

Water-Resistant Solid State Switch with 2-Colour Display: Direct Mounting Type D-F9BAL

Grommet

Water-resistant type
(for coolant also)



Caution

Usage

Consult with SMC if the switches are to be used with a liquid other than water.

Internal circuits

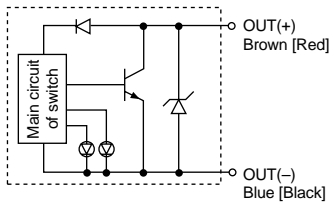

Indicator light

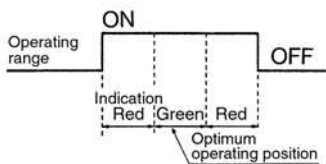

Specifications

D-F9BAL (with indicator light)	
Auto switch part no.	D-F9BAL
Wiring type	2-wire
Output type	—
Applicable load	24VDC relay, PLC
Power supply voltage	—
Current consumption	—
Load voltage	24VDC (10 to 28VDC)
Load current	5 to 30mA
Internal voltage drop	5V or less
Leakage current	1mA or less at 24VDC
Indicator light	Operating position Red LED lights up Optimum operating position ... Green LED lights up

- Lead wire Oilproof, heavy-duty vinyl cord: $\phi 2.7$, 0.5m, 0.18mm² x 2 cores (Brown, Blue [Red, Black])

Note) Refer to page 40 for auto switch common specifications and lead wire lengths.

Weight

(g)	
Auto switch part no.	D-F9BAL
Lead wire length: 3m	37

Dimensions

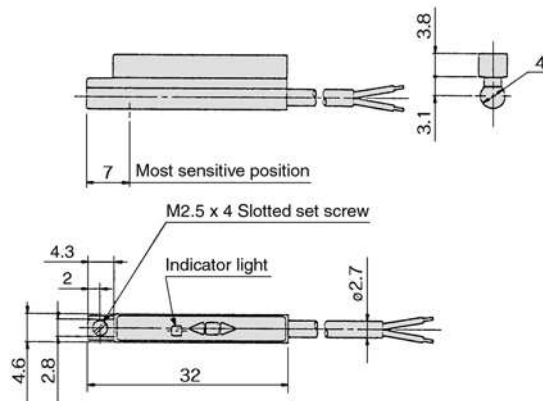

Reed Switches: Direct Mounting Type

D-Z73, D-Z76, D-Z80



Specifications

D-Z73, D-Z76 (with indicator light)			
Auto switch part no.	D-Z73		D-Z76
Electrical entry direction	In-line		
Applicable load	Relay, PLC		IC circuit
Load voltage	24VDC	100VAC	4 to 8VDC
Maximum load current and Load current range	5 to 40mA	5 to 20mA	20mA
Contact protection circuit	Not available		
Internal voltage drop	2.4V or less (up to 20mA), 3V or less (up to 40mA)		0.8V or less
Indicator light	Red LED lights when ON		

D-Z80 (without indicator light)			
Auto switch part no.	D-Z80		
Electrical entry direction	In-line		
Applicable load	Relay, PLC, IC circuit		
Load voltage	24V ^{AC} _{DC} or less	48V ^{AC} _{DC} or less	100V ^{AC} _{DC} or less
Maximum load current	50mA	40mA	20mA
Contact protection circuit	Not available		
Internal resistance	1Ω or less (includes 3m lead wire length)		

- Lead wire Oilproof, heavy-duty vinyl cord: 0.5m
 D-Z76: ø3.4, 0.2mm² x 2 cores (Brown, Blue [Red, Black])
 D-Z80: ø3.4, 0.2mm² x 3 cores (Brown, Black, Blue [Red, White, Black])
 D-Z73: ø2.7, 0.18mm² x 2 cores (Brown, Blue [Red, Black])

Note) Refer to page 40 for auto switch common specifications and lead wire lengths.

Internal circuits

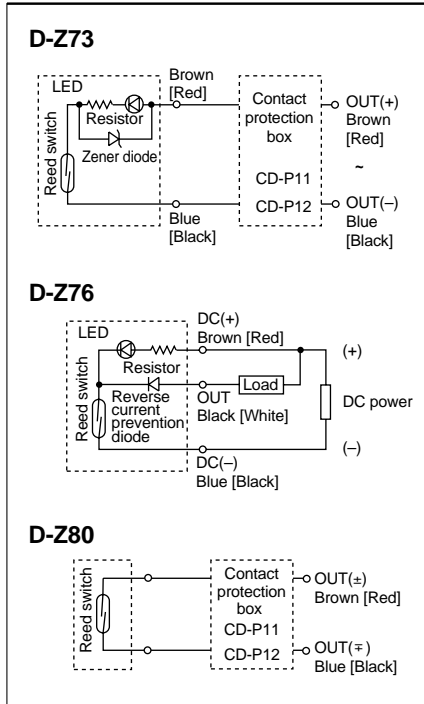

Note) A contact protection box should be used in any of the following conditions to prevent the shortening of the working life of the switch. (Refer to page 40 regarding the detailed specification for contact protection box):

1. Operated load is an induction load.
2. The length of wiring to the load is 5m or more.
3. The load voltage is 100VAC.

Weights

Auto switch part no.	Lead wire length: 0.5m		Lead wire length: 3m
	(g)		
D-Z73	6	31	
D-Z76	10	55	
D-Z80	9	49	

Dimensions

D-Z73

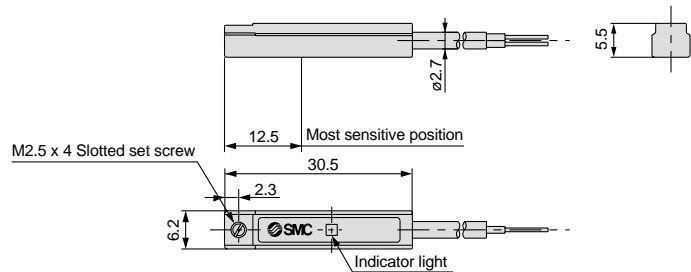

D-Z76, D-Z80

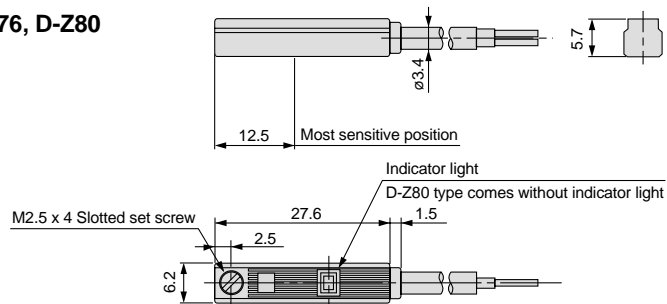

Solid State Switches: Direct Mounting Type

D-Y59^A_B, D-Y69^A_B, D-Y7P(V)



Specifications

D-Y5, D-Y6, D-Y7P, D-Y7PV (with indicator light)						
Auto switch part no.	D-Y59A	D-Y69A	D-Y7P	D-Y7PV	D-Y59B	D-Y69B
Electrical entry direction	In-line	Perpendicular	In-line	Perpendicular	In-line	Perpendicular
Wiring type	3-wire				2-wire	
Output type	NPN		PNP		—	
Applicable load	IC circuit, Relay, PLC				24VDC relay, PLC	
Power supply voltage	5, 12, 24VDC (4.5 to 28VDC)				—	
Current consumption	10mA or less				—	
Load voltage	28VDC or less		—		24VDC (10 to 28VDC)	
Load current	40mA or less		80mA or less		5 to 40mA	
Internal voltage drop	1.5V or less (0.8V or less at 10mA load current)		0.8V or less		4V or less	
Leakage current	100 μ A or less at 24VDC				0.8mA or less at 24VDC	
Indicator light	Red LED lights when ON					

- Lead wire Oilproof, heavy-duty, flexible vinyl cord: ϕ 3.4, 0.5m
 D-Y59A, D-Y69A, D-Y7P(V): 0.15mm² x 3 cores (Brown, Black, Blue [Red, White, Black])
 D-Y59B, D-Y69B: 0.15mm² x 2 cores (Brown, Blue [Red, Black])

Note) Refer to page 40 for auto switch common specifications and lead wire lengths.

Weights

Auto switch part no.	Lead wire length	
	0.5m	3m
D-Y59A, D-Y69A, D-Y7P, D-Y7PV	10	53
D-Y59B, D-Y69B	9	50

Internal circuits

D-Y59A, D-Y69A

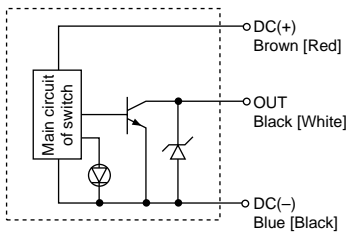

D-Y7P(V)

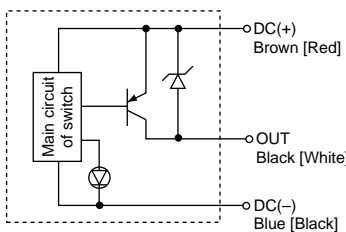

D-Y59B, D-Y69B

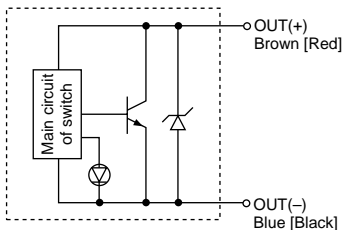

Dimensions

D-Y59A, D-Y59B D-Y7P

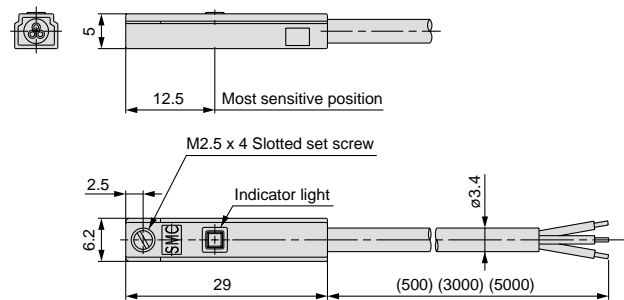

D-Y69A, D-Y69B D-Y7PV

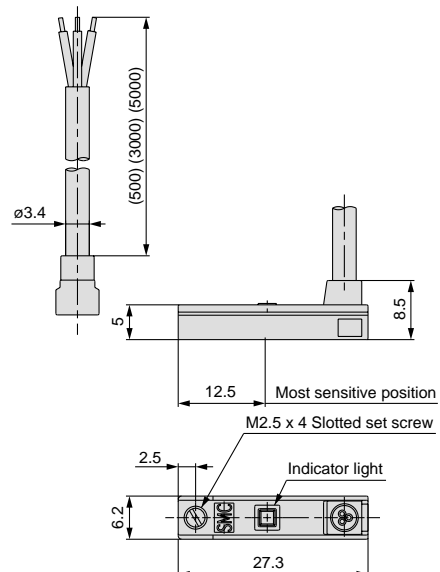

Solid State Switches with 2-Colour Display: Direct Mounting Type

D-Y7NW(V), D-Y7PW(V), D-Y7BW(V)

Compact Type
CXSJ

Standard Type
CXS

With Air Cushion
CXS

With End Lock
CXS

Dual-Rod Type
CXS

Auto Switches

Made to Order

Precautions

Grommet



Specifications

D-Y7□W, D-Y7□WV (with indicator light)						
Auto switch part no.	D-Y7NW	D-Y7NWV	D-Y7PW	D-Y7PWV	D-Y7BW	D-Y7BWV
Electrical entry direction	In-line	Perpendicular	In-line	Perpendicular	In-line	Perpendicular
Wiring type	3-wire			2-wire		
Output type	NPN		PNP		—	
Applicable load	IC circuit, Relay, PLC				24VDC relay, PLC	
Power supply voltage	5, 12, 24VDC (4.5 to 28VDC)				—	
Current consumption	10mA or less				—	
Load voltage	28VDC or less		—		24VDC (10 to 28VDC)	
Load current	40mA or less		80mA or less		5 to 40mA	
Internal voltage drop	1.5V or less (0.8V or less at 10mA load current)		0.8V or less		4V or less	
Leakage current	100μA or less at 24VDC				0.8mA or less at 24VDC	
Indicator light	Operating position Red LED lights up Optimum operating position Green LED lights up					

- Lead wire Oilproof, heavy-duty, flexible vinyl cord: $\phi 3.4$, 0.5m
D-Y7NW(V), D-Y7PW(V): 0.15mm² x 3 cores (Brown, Black, Blue [Red, White, Black])
D-Y7BW(V): 0.15mm² x 2 cores (Brown, Blue [Red, Black])

Note) Refer to page 40 for auto switch common specifications and lead wire lengths.

Weights

Auto switch part no.	Lead wire length	
	0.5m	3m
D-Y7NW, D-Y7NWV, D-Y7PW, D-Y7PWV	11	54
D-Y7BW, D-Y7BWV	11	54

Dimensions

D-Y7NW, D-Y7PW
D-Y7BW

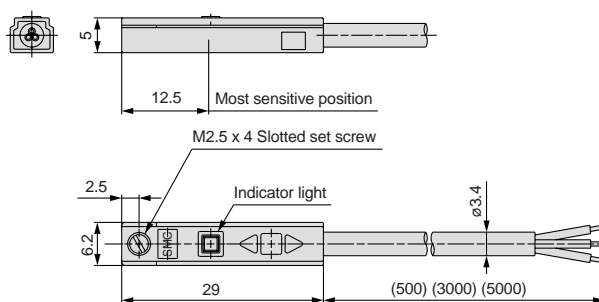

D-Y7NWV, D-Y7PWV
D-Y7BWV

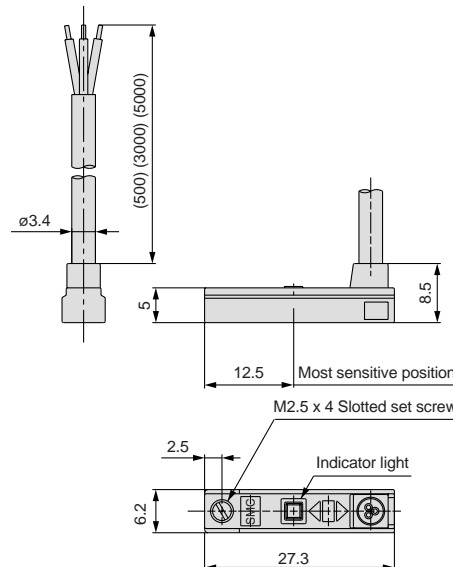

Internal circuits

D-Y7NW(V)

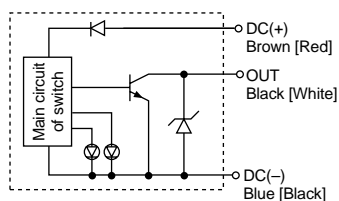

D-Y7PW(V)

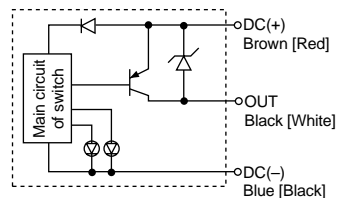

D-Y7BW(V)

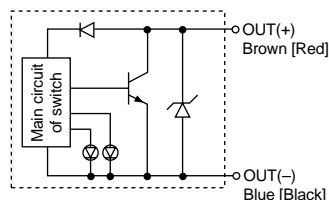

Indicator light

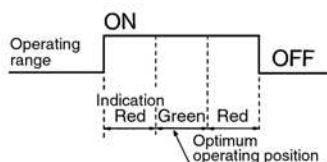

Water-Resistant Solid State Switch with 2-Colour Display: Direct Mounting Type D-Y7BAL

Grommet

Water-resistant type
(for coolant also)



Usage

⚠ Caution

Consult with SMC if the switches are to be used with a liquid other than water.

Internal circuits

D-Y7BAL

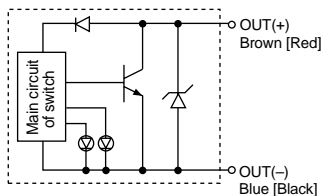

Indicator light

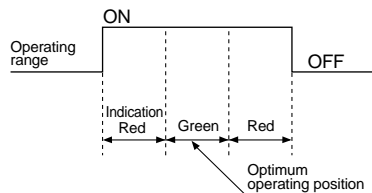

Specifications

D-Y7BAL (with indicator light)	
Auto switch part no.	D-Y7BAL
Electrical entry direction	In-line
Wiring type	2-wire
Applicable load	24VDC relay, PLC
Load voltage	24VDC (10 to 28VDC)
Load current	5 to 40mA
Internal voltage drop	4V or less
Leakage current	0.8mA or less at 24VDC
Indicator light	Operating position Red LED lights up Optimum operating position Green LED lights up

- Lead wire Oilproof, heavy-duty, flexible vinyl cord: $\phi 3.4$, 3m, 0.15mm² x 2 cores (Brown, Blue [Red, Black])

Note) Refer to page 40 for auto switch common specifications and lead wire lengths.

Weight

Auto switch part no.	Lead wire length
	3m
D-Y7BAL	54

(g)

Dimensions

D-Y7BAL

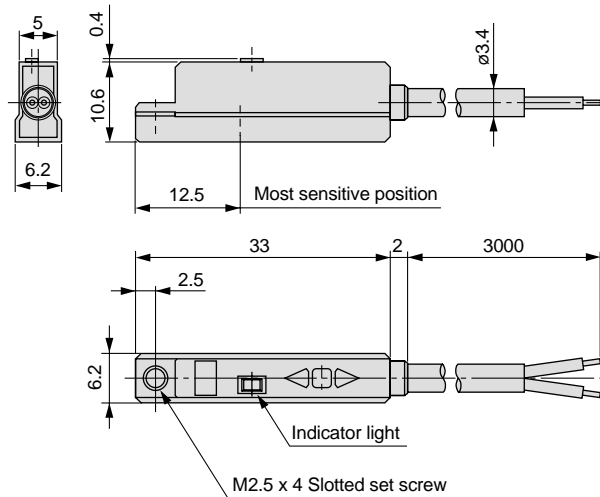

Auto Switch Connections and Examples

Basic Wiring

Solid state 3-wire, NPN

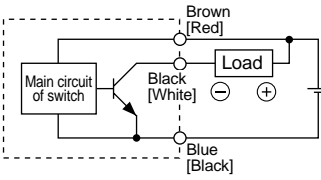

(Power supplies for switch and load are separate.)

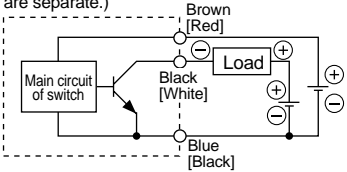

Solid state 3-wire, PNP

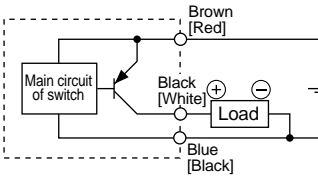

2-wire <Solid state>

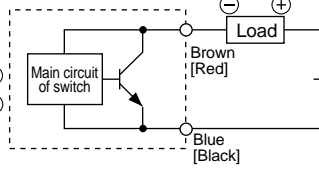

2-wire <Reed switch>

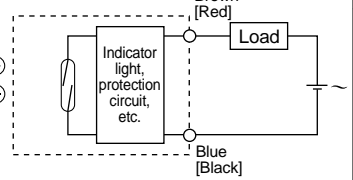

Examples of Connection to PLC

Sink input specifications

3-wire, NPN

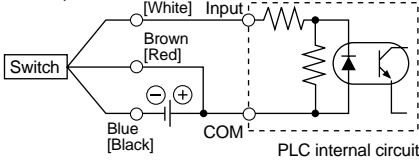

2-wire

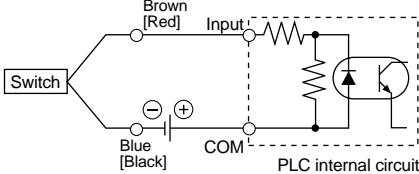

Source input specifications

3-wire, PNP

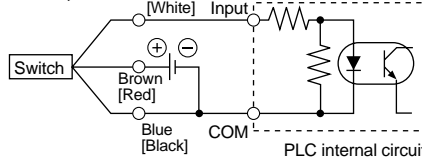

2-wire

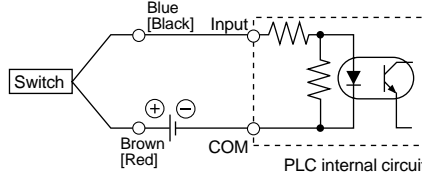

The connection method will vary depending on the applicable PLC input specifications.

Connection Examples for AND (Series) and OR (Parallel)

3-wire

AND connection for NPN output (using relays)

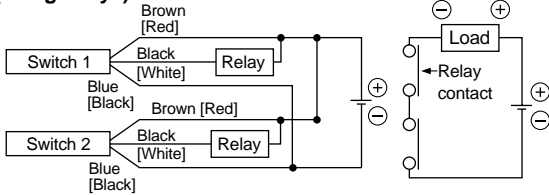

AND connection for NPN output (performed with switches only)

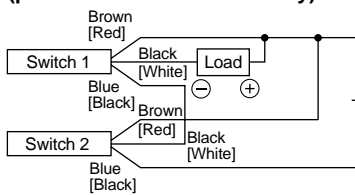

OR connection for NPN output

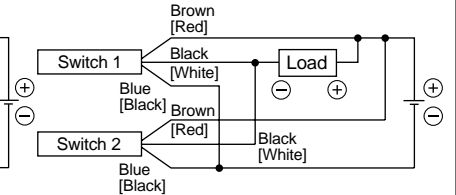

The indicator lights will light up when both switches are turned ON.

2-wire with 2-switch AND connection

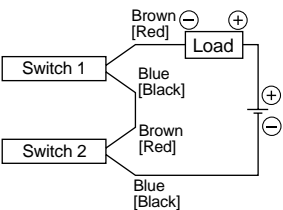

When two switches are connected in series, a load may malfunction because the load voltage will decline when in the ON state. The indicator lights will light up if both of the switches are in the ON state.

2-wire with 2-switch OR connection

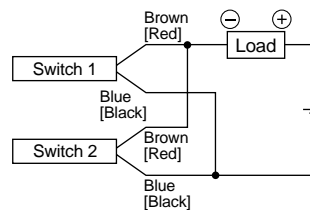

<Solid state>
When two switches are connected in parallel, malfunction may occur because the load voltage will increase when in the OFF state.

<Reed switch>
Because there is no current leakage, the load voltage will not increase when turned OFF. However, depending on the number of switches in the ON state, the indicator lights may sometimes grow dim or not light up because of the dispersion and reduction of the current flowing to the switches.

$$\begin{aligned} \text{Load voltage at ON} &= \text{Power supply voltage} - \text{Internal voltage drop} \times 2 \text{ pcs.} \\ &= 24\text{V} - 4\text{V} \times 2 \text{ pcs.} \\ &= 16\text{V} \end{aligned}$$

Example: Power supply is 24VDC.
Internal voltage drop in switch is 4V.

$$\begin{aligned} \text{Load voltage at OFF} &= \text{Leakage current} \times 2 \text{ pcs.} \times \text{Load impedance} \\ &= 1\text{mA} \times 2 \text{ pcs.} \times 3\text{k}\Omega \\ &= 6\text{V} \end{aligned}$$

Example: Load impedance is 3kΩ.
Leakage current from switch is 1mA.

Series CXS Made to Order Specifications 1



Contact SMC regarding the availability of Made to Order specifications for Compact Type Dual-Rod Cylinder, Dual-Rod Cylinder with Air Cushion/End Lock, or Dual-Double-Rod Cylinder.

Made to order description		Symbol
①	Heat-resistant cylinder	-XB6
②	Low-speed cylinder (10 to 50mm/s)	-XB9
③	Low-speed cylinder (5 to 50mm/s)	-XB13
④	Long-stroke cylinder	-XB11

Made to order description		Symbol
⑤	High-speed cylinder	-XB19
⑥	NPT finish piping port	-XC18
⑦	Fluoro rubber seal	-XC22
⑧	Without plate	-X593

1 Heat-resistant cylinder

-XB6

CXS Bore size Stroke - **XB6**

Heat-resistant cylinder

Air cylinder whose seal and grease materials are changed to withstand the applications in the ambient temperature of up to 150°C.

Note 1) Operate without lubrication from a pneumatic system lubricator.

Note 2) Maintenance period for this type of cylinder is different from that of the standard cylinder. Contact SMC.

Note 3) Heat-resistant cylinder with auto switch is not available per Made to Order specifications. Contact SMC if such cylinders are required.

Warning

Operating precautions

Be sure to wash your hands after handling the grease used for this cylinder. Toxic gas may be released when you smoke with the grease residual left on your hands, causing a health hazard.

Specifications

Series	CXSM	CXSL
Bearing type	Slide bearing	Ball bushing bearing
Lubrication	Non-lube	
Bore size (mm)	ø6, ø10, ø15, ø20, ø25, ø32	
Ambient temperature	-10° to 150°C	
Seal material	Fluoro rubber	
Grease	Heat-resistant grease	
Other specifications and dimensions	Refer to pages 10 through 17.	

2 Low-speed cylinder (10 to 50mm/s)

-XB9

CXS Bore size Stroke Auto switch - **XB9**

Low-speed cylinder

This cylinder operates smoothly with minimal stick-slip even at 10 to 50mm/s.

Note) Operate without lubrication from a pneumatic system lubricator.

Warning

Operating precautions

Be sure to wash your hands after handling the grease used for this cylinder. Toxic gas may be released when you smoke with the grease residue left on your hands, causing a health hazard.

Specifications

Series	CXSM	CXSL
Bearing type	Slide bearing	Ball bushing bearing
Lubrication	Non-lube	
Bore size (mm)	ø6, ø10, ø15, ø20, ø25, ø32	
Piston speed	10 to 50mm/s	
Cushion	Rubber bumper	
Auto switch	Mountable	
Other specifications and dimensions	Refer to pages 10 through 17.	

3 Low-speed cylinder (5 to 50mm/s)

-XB13

CXS Bore size Stroke Auto switch - **XB13**

Low-speed cylinder

This cylinder operates smoothly with minimal stick-slip even at 5 to 50mm/s.

Note 1) Operate without lubrication from a pneumatic system lubricator.

Note 2) Use a low speed controller (Series AS-FM, AS-M) to adjust a speed.

Specifications

Series	CXSM	CXSL
Bearing type	Slide bearing	Ball bushing bearing
Bore size (mm)	ø6, ø10, ø15, ø20, ø25, ø32	
Piston speed	5 to 50mm/s	
Cushion	Rubber bumper	
Auto switch	Mountable	
Other specifications and dimensions	Refer to pages 10 through 17.	

Series CXS Made to Order Specifications 2



Contact SMC regarding the availability of Made to Order specifications for Compact Type Dual-Rod Cylinder, Dual-Rod Cylinder with Air Cushion/End Lock, or Dual-Double-Rod Cylinder.

Compact Type
CXSJ

Standard Type
CXS

With Air Cushion
CXSL

With End Lock
CXSS

Dual-Double-Rod Type
CXSW

Auto Switches

Made to Order

Precautions

4 Long-stroke cylinder

-XB11

CXS
CXSW Bore size Stroke Auto switch -XB11

Long-stroke cylinder

Long-stroke cylinder whose stroke range is beyond that of the standard.

Note) The specification for long-stroke cylinder -XB11 is available within the ranges shown in the table at right. Cylinders with even longer strokes are available as a special order.

Specifications

Series	CXSM, CXSWM	CXSL, CXSWL
Bearing type	Slide bearing	Ball bushing bearing
Bore size (mm)	ø10, ø15, ø20, ø25, ø32	
Auto switch	Mountable	
Other specifications and dimensions	Refer to pages 10 through 17.	

Stroke range

Series	Bore sizes (mm)	Standard strokes (mm)	Long strokes (mm)
CXSM CXSL	10	10 to 75	80, 90, 100, 110, 120, 125, 150
	15	10 to 100	110, 120, 125, 150
20, 25, 32	110, 120, 125, 150, 175, 200		

CXSWM CXSWL	10, 15	10, 20, 30, 40, 50	75, 100, 125, 150
	20, 25, 32	10, 20, 30, 40, 50, 75, 100	125, 150, 175, 200

Dimensions

CXS□10, 15

CXS□20, 25, 32

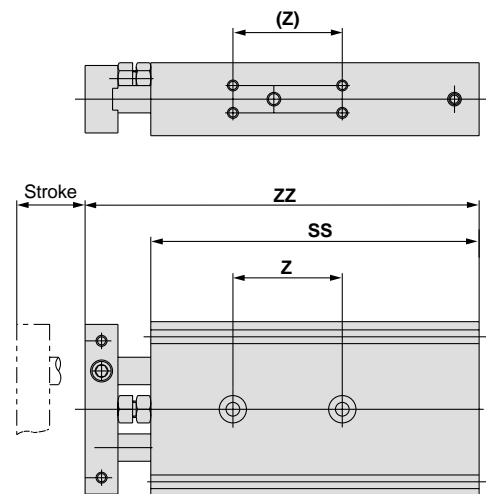
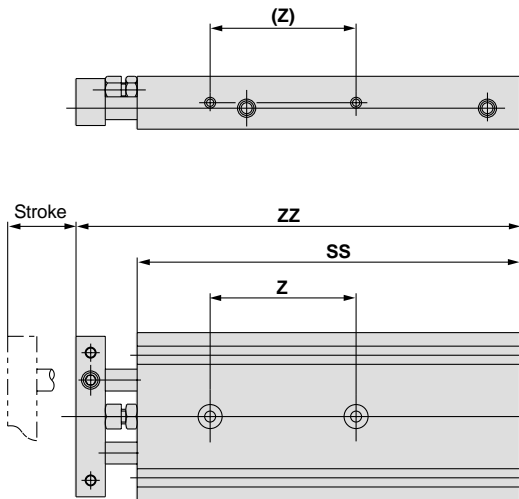

Model	CXS□10							CXS□15				CXS□20						CXS□25						CXS□32												
Stroke	80	90	100	110	120	125	150	110	120	125	150	110	120	125	150	175	200	110	120	125	150	175	200	110	120	125	150	175	200	110	120	125	150	175	200	
Symbol	SS	135	145	155	165	175	180	205	170	180	185	210	180	190	195	220	245	270	182	192	197	222	247	272	192	202	207	232	257	282	222	232	237	262	287	312
	ZZ	152	162	172	182	192	197	222	189	199	204	229	204	214	219	244	269	294	206	216	221	246	271	296	222	232	237	262	287	312	222	232	237	262	287	312
	Z	50	60		70			80	65	75			80			100			80			100			90						110					

Refer to pages 36 through 38 for dimensions of CXSW dual-double-rod cylinder.

Series CXS Made to Order Specifications 3



Contact SMC regarding the availability of Made to Order specifications for Compact Type Dual-Rod Cylinder, Dual-Rod Cylinder with Air Cushion/End Lock, or Dual-Double-Rod Cylinder.

5 High-speed cylinder

-XB19

CXS Bore size Stroke Auto switch - XB19

High-speed cylinder

Oversized orifice for twice the speed of the standard cylinder (Max. 1500mm/s for $\phi 6$ to $\phi 20$, and Max. 1000mm/s for $\phi 25$ and $\phi 32$). The absorbed energy of the retracted end bumper and strength of a plate and piston rod connection are improved.

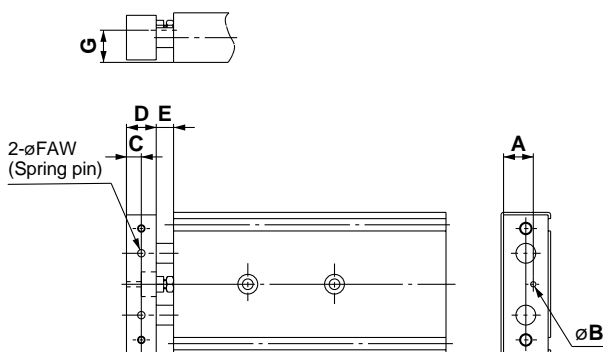

Specifications

Series: Bearing type	CXSM: Slide bearing, CXSL: Ball bushing bearing					
Bore size (mm)	6	10	15	20	25	32
Proof pressure	1.05MPa					
Maximum operating pressure	0.7MPa					
Minimum operating pressure	0.15MPa	0.1MPa	0.05MPa			
Fluid	Air (non-lube)					
Ambient and fluid temperature	-10° to 60°C (with no freezing)					
Piston speed	30 to 1500mm/s				30 to 1000mm/s	
Port size	M5 x 0.8				Rc 1/8	
Stroke adjustable range	0 to -5mm compared to the standard stroke					
Bearing type	Slide bearing, Ball bushing bearing (Same dimensions for both)					
Cushion	Rubber bumper					

* The maximum piston speed shown in the table above is for extension.
The maximum piston speeds for retraction is approximately 70% that of the extension.

Model	A	B	C	D	E	F	G
CXS□6	9	2.1	3.25	6.5	7	1.2 x 12	10
CXS□10	9	2.1	5	10	7	2.5 x 14	10
CXS□15	12	2.1	6	12	7	3 x 16	13
CXS□20	15	3.1	7	14	10	4 x 20	16
CXS□25	20	3.1	7	14	10	5 x 22	21
CXS□32	26	4.1	9	18	12	6 x 32	27

* Dimensions other than those listed above are the same as for the standard type.

6 NPT finish piping port

-XC18

CXS Bore size Stroke Auto switch - XC18

NPT finish piping port

Piping port thread NPT is used instead of Rc.

Specifications

Series	CXSM	CXSL
Bearing type	Slide bearing	Ball bushing bearing
Bore size (mm)	$\phi 25, \phi 32$	
Cushion	Rubber bumper	
Auto switch	Mountable	
Other specifications and dimensions	Refer to pages 10 through 17.	

7 Fluoro rubber seal

-XC22

CXS Bore size Stroke Auto switch - XC22

Fluoro rubber seal

Chemical-resistant fluoro rubber is used for seal materials.

Note 1) Contact SMC upon operation of the cylinder with fluoro rubber seal. Although the seal material of this cylinder is chemical-resistant, the cylinder is not suitable and should not be operated with certain types of chemical and/or the operating temperature.

Note 2) Auto switch cylinders can be manufactured. However, contact SMC regarding the applicability of the cylinder in your desired operating environment before the cylinder is put into service since auto switch related parts (such as auto switch body, mounting bracket, built-in magnet) are same as those of the standard cylinders.

Specifications

Series	CXSM	CXSL
Bearing type	Slide bearing	Ball bushing bearing
Bore size (mm)	$\phi 6, \phi 10, \phi 15, \phi 20, \phi 25, \phi 32$	
Ambient temperature range	Without auto switch: -10°C to 70°C With auto switch: -10° to 60°C (with no freezing)	
Cushion	Rubber bumper (Both sides)	
Auto switch	Mountable	
Other specifications and dimensions	Refer to pages 10 through 17.	

Series CXS Made to Order Specifications 4



Contact SMC regarding the availability of Made to Order specifications for Compact Type Dual-Rod Cylinder, Dual-Rod Cylinder with Air Cushion/End Lock, or Dual-Double-Rod Cylinder.

8 Without plate

-X593

CXS Bore size Stroke Auto switch -X593

Without plate ●

This specification is for the cylinder without a plate. This cylinder is suitable for mounting your own plate. Please note that the rod end dimensions of this cylinder are different from those of the standard cylinder.

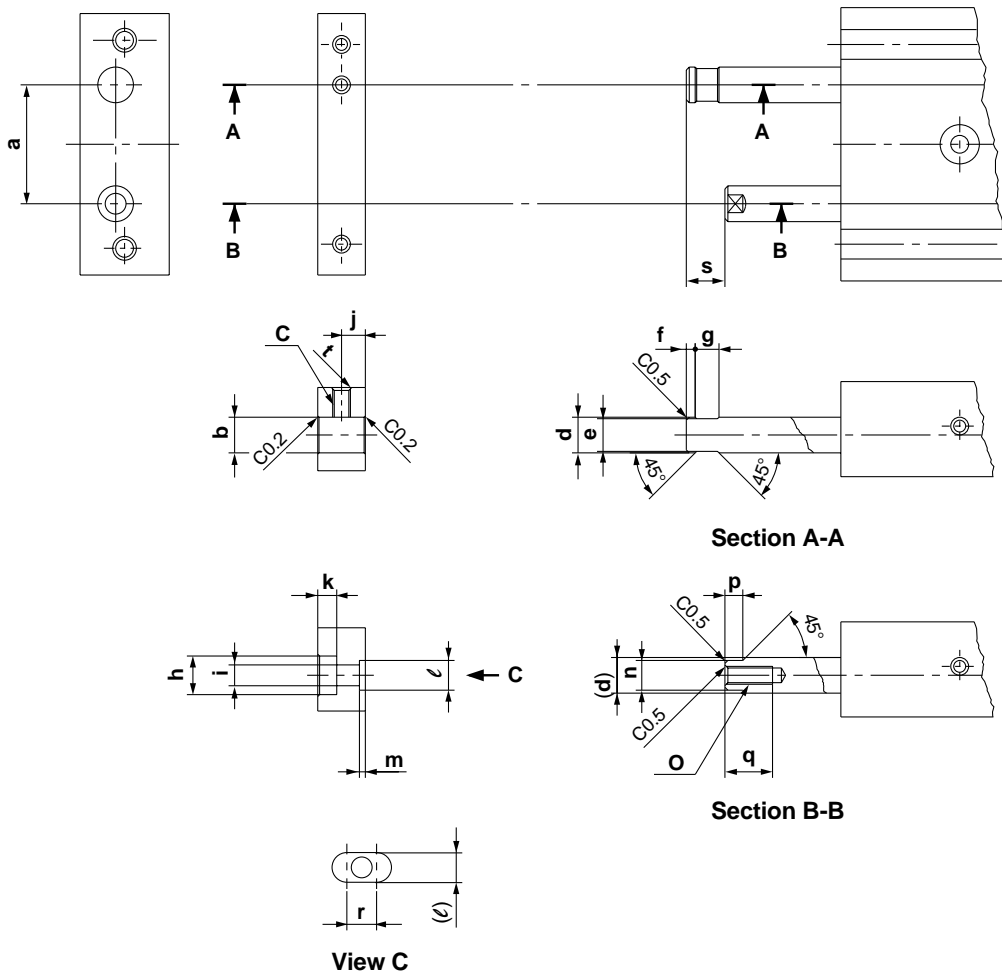

Model	a	b	c	d	e	f	g	h	i	j	k	ℓ	m	n	o	p	q	r	s	t
CXS□6	16 ±0.1	ø4 ^{+0.013} / _{+0.001}	M3	ø4	ø3.5	1	3	ø5.5	ø6 ⁰ / _{-0.2}	2.75	2.8 ^{+0.2} / ₀	3.5 ^{+0.1} / ₀	0.5 ^{+0.2} / ₀	3.5 ^{-0.05} / _{-0.15}	M2.5	3	4.5	3.5	4.75	C0.5
CXS□10	20 ±0.1	ø6 ^{+0.016} / _{+0.001}	M5	ø6	ø5.5	1.25	4.5	ø6.5	ø3.5 ⁰ / _{-0.2}	4	3.2 ^{+0.2} / ₀	5 ^{+0.1} / ₀	1 ^{+0.2} / ₀	5 ^{-0.05} / _{-0.15}	M3		8	5	6.5	C0.5
CXS□15	25 ±0.1	ø8 ^{+0.016} / _{+0.001}	M6	ø8	ø7.5	2	5	ø9.5	ø5.5 ⁰ / _{-0.2}	5	5.2 ^{+0.3} / ₀	6 ^{+0.2} / ₀	1.5 ^{+0.2} / ₀	6 ^{-0.05} / _{-0.15}	M5		8	7	8	C0.5
CXS□20	28 ±0.1	ø10 ^{+0.016} / _{+0.001}	M8	ø10	ø9.5	2	7	ø11	ø6.6 ⁰ / _{-0.2}	6	6.2 ^{+0.3} / ₀	8 ^{+0.2} / ₀	2 ^{+0.2} / ₀	8 ^{-0.05} / _{-0.15}	M6		10	8	9.5	C0.5
CXS□25	35 ±0.1	ø12 ^{+0.019} / _{+0.001}	M8	ø12	ø11.5	2	7	ø11	ø6.6 ⁰ / _{-0.2}	6	6.2 ^{+0.3} / ₀	10 ^{+0.2} / ₀	2 ^{+0.2} / ₀	10 ^{-0.05} / _{-0.15}	M6		12	8.5	9.5	C0.7
CXS□32	44 ±0.1	ø16 ^{+0.019} / _{+0.001}	M10	ø16	ø15.5	3.5	8	ø14	ø9 ⁰ / _{-0.2}	8	8.2 ^{+0.4} / ₀	13 ^{+0.2} / ₀	2 ^{+0.2} / ₀	13 ^{-0.05} / _{-0.15}	M8		12.5	11	13.5	C0.7

Notes) • Dimension tolerances that are not indicated in the table above are based on JIS B 0405 Permissible Machining Deviations in Dimensions without Tolerance Indication.

• Piston rod A and B must be extended in order to install a plate. Supply air (0.2MPa or more) from the supply port of the extended end when installing a plate. When installing the plate, first secure the plate on piston rod B, and then piston rod A afterward. Apply Loctite® to the mounting threads. After anchoring the plate, operate the cylinder to check for proper operation (e.g., the cylinder operates smoothly when moved by hand or at least operates properly at the minimum operating pressure).

Series CXS

Model Selection

⚠ Caution Theoretical output must be confirmed separately, referring to the table on page 2.

Compact Type: CXSJ

Vertical mounting

Mounting orientation											
	Maximum speed (mm/s)		up to 200		up to 400		up to 600		up to 800		
Stroke (mm)		All strokes									
Selection graph	∅6	1		2		3		4			
	∅10	1		2		3		4			

Horizontal mounting

Mounting orientation													
	* Refer to the caution notes below.												
Stroke (mm)		up to 10		up to 30		up to 50		up to 75					
Maximum speed (mm/s)		up to 400		up to 800		up to 400		up to 800		up to 400		up to 800	
Selection graph	∅6	5		6		7		8					
	∅10	5		6		7		8					

⚠ Caution

If the cylinder is horizontally mounted and the plate end does not reach the load's centre of gravity, use the formula below to calculate the imaginary stroke L' that includes the distance between the load's centre of gravity and the plate end. Select the graph that corresponds to the imaginary stroke L' .

$$\text{Imaginary stroke } L' = (\text{Stroke}) + k + L$$

k: Distance between the centre and end of the plate

∅6	2.75mm
∅10	4mm

(Example)

When using CXSJM6-10 and $L = 15\text{mm}$:

Imaginary stroke $L' = 10 + 2.75 + 15 = 27.75$

Therefore, the graph used for your model selection should be the one for CXSJM6-30 ([6]).

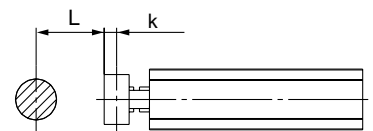

Series CXS

Vertical Mounting [based on maximum speed (v)]

Graph 1 V = up to 200mm/s

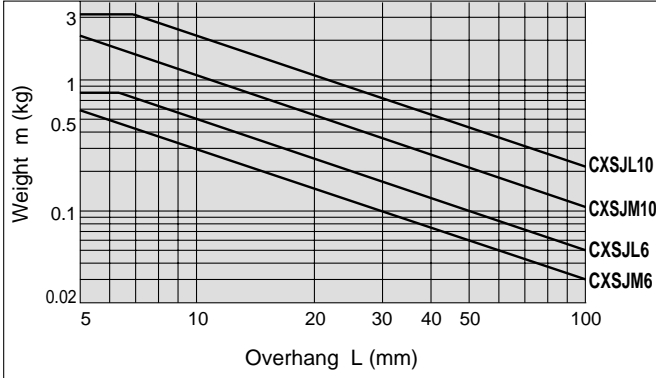

Graph 2 V = up to 400mm/s

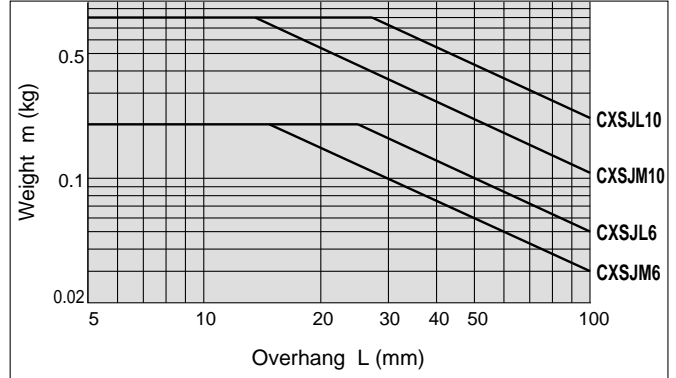

Graph 3 V = up to 600mm/s

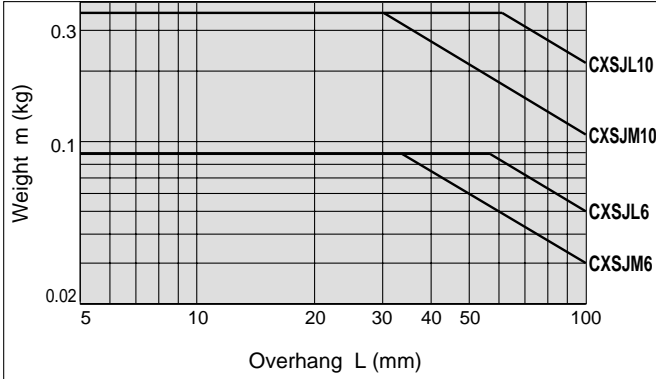

Graph 4 V = up to 800mm/s

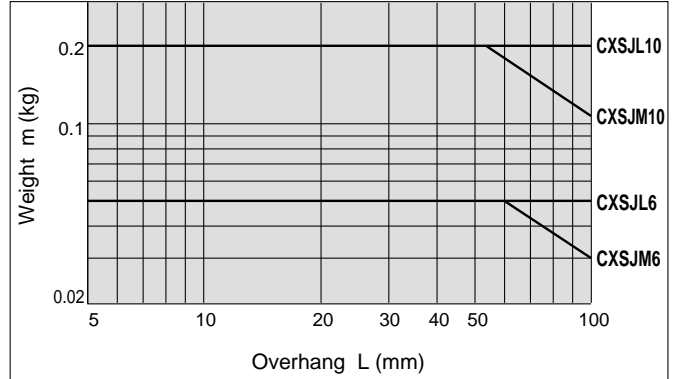

Horizontal Mounting [based on stroke length]

Graph 5 up to 10mm

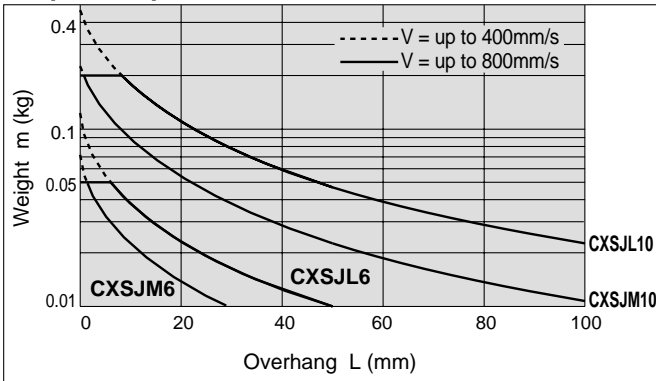

Graph 6 up to 30mm

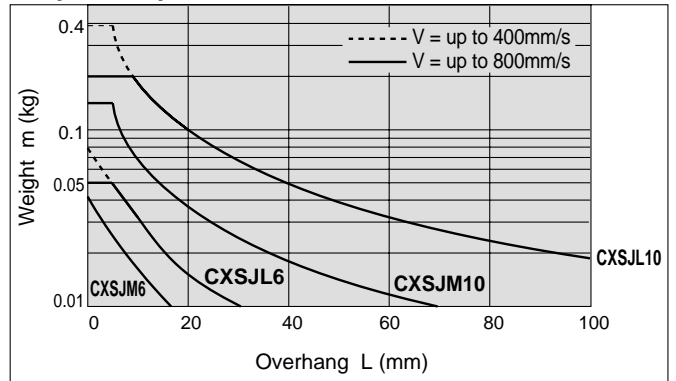

Graph 7 up to 50mm

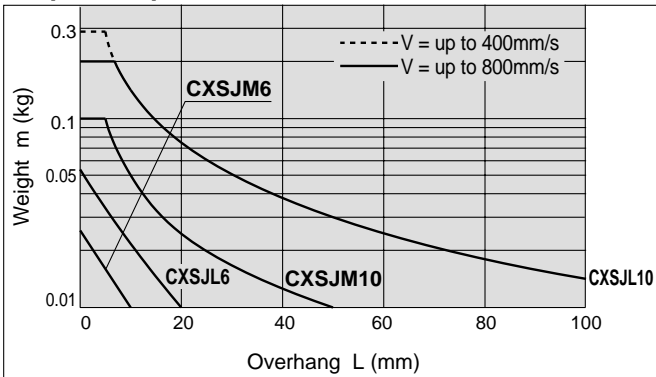

Graph 8 up to 75mm

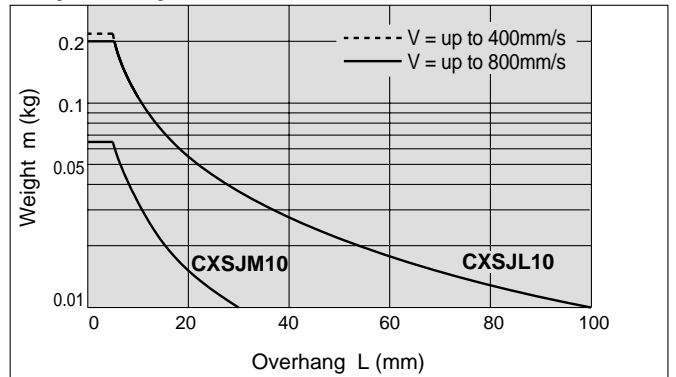

Series CXS

Model Selection

⚠ Caution Theoretical output must be confirmed separately, referring to the table on page 10.

Standard Type: CXS

Vertical mounting

Mounting orientation						
Max. speed (mm/s)	up to 100	up to 200	up to 300	up to 400	up to 600	up to 700 (up to 800)
Stroke (mm)	All strokes					
Selection graph	ø6	1		2		
	ø10					
	ø15					
	ø20	3		4		5
	ø25					6
	ø32					

Horizontal mounting

Mounting orientation																				
Stroke (mm)	up to 10				up to 30				up to 50				up to 75				up to 100			
Max. speed (mm/s)	up to 100	up to 300	up to 400	More than 400	up to 100	up to 300	up to 400	More than 400	up to 100	up to 300	up to 400	More than 400	up to 100	up to 300	up to 400	More than 400	up to 100	up to 300	up to 400	More than 400
Selection graph	ø6	7				8				9										
	ø10																			
	ø15																			
	ø20	10		11		12		13		14		15		16		17				
	ø25																			
	ø32																			

* Refer to the caution notes below.

* The maximum speeds for ø10 to ø32 are:
 ø10: up to 800mm/s; ø15, 20: up to 700mm/s; ø25, 32: up to 600mm/s

⚠ Caution

If the cylinder is horizontally mounted and the plate end does not reach the load's centre of gravity, use the formula below to calculate the imaginary stroke L' that includes the distance between the load's centre of gravity and the plate end. Select the graph that corresponds to the imaginary stroke L'.

$$\text{Imaginary stroke } L' = (\text{Stroke}) + k + L$$

k: Distance between the centre and end of the plate

ø6	2.75mm
ø10	4mm
ø15	5mm
ø20	6mm
ø25	
ø32	8mm

(Example)
 When using CXSM6-10 and L = 15mm:
 Imaginary stroke L' = 10 + 2.75 + 15 = 27.75
 Therefore, the graph used for your model selection should be the one for CXSM6-30 (8).

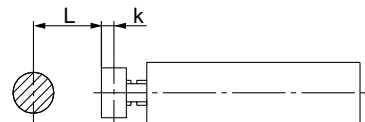

Series CXS

Vertical Mounting [based on maximum speed (V)]

∅6

Graph 1 V = up to 100mm/s

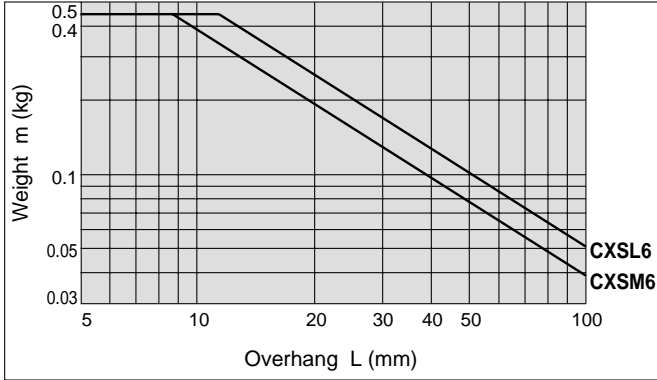

Graph 2 V = up to 300mm/s

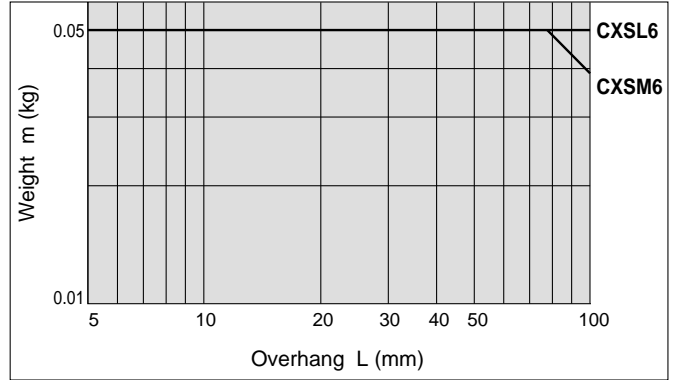

∅10 to ∅32

Graph 3 V = up to 200mm/s

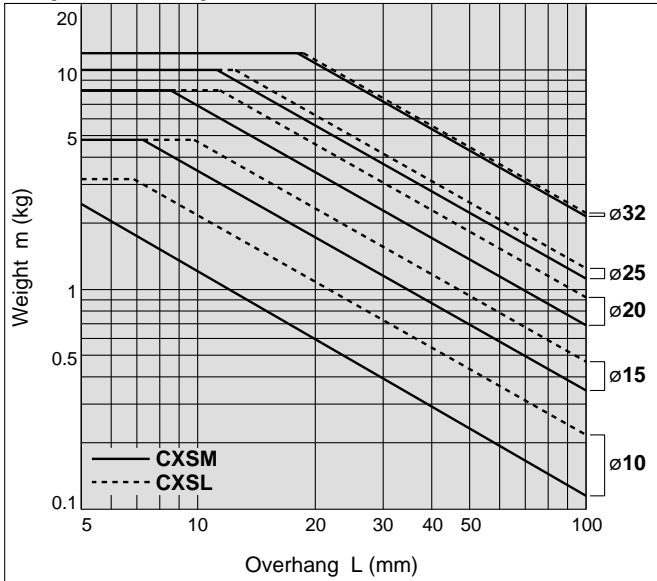

Graph 4 V = up to 400mm/s

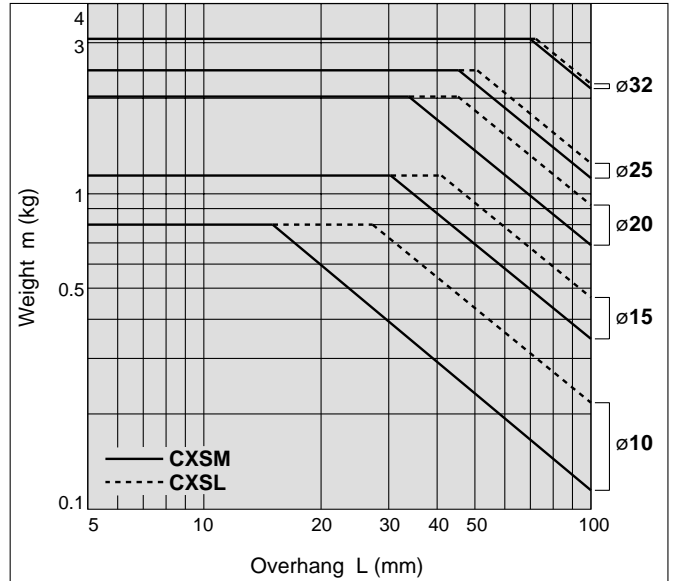

Graph 5 V = up to 600mm/s

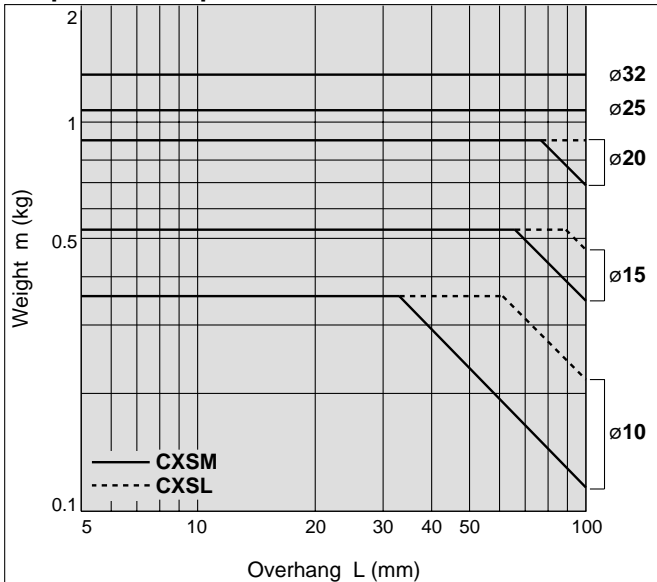

Graph 6 V = up to 700mm/s (up to 800mm/s for ∅10)

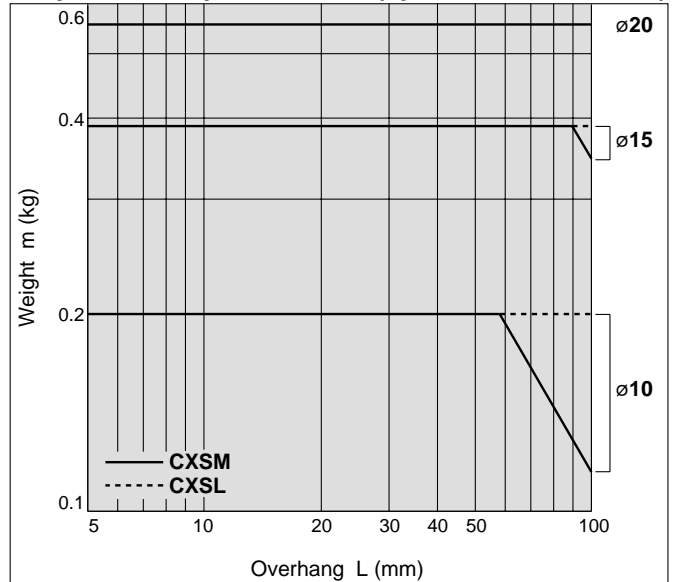

Horizontal Mounting [based on stroke length]

∅6

Graph 7 up to 10mm

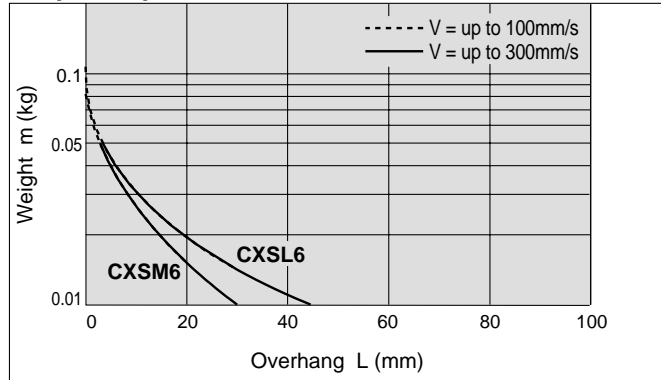

Graph 8 up to 30mm

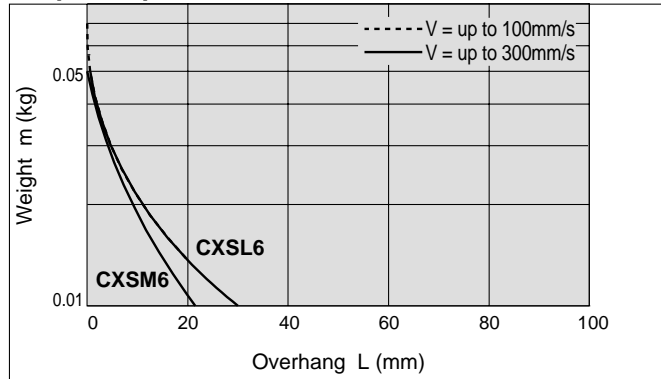

Graph 9 up to 50mm

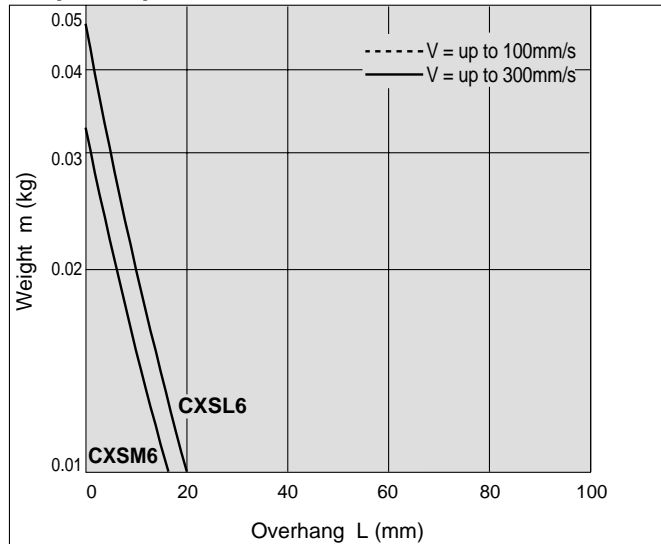

[based on maximum speed (V) and stroke length]

∅10 to ∅32

Graph 10 V = up to 400mm/s; up to 10mm

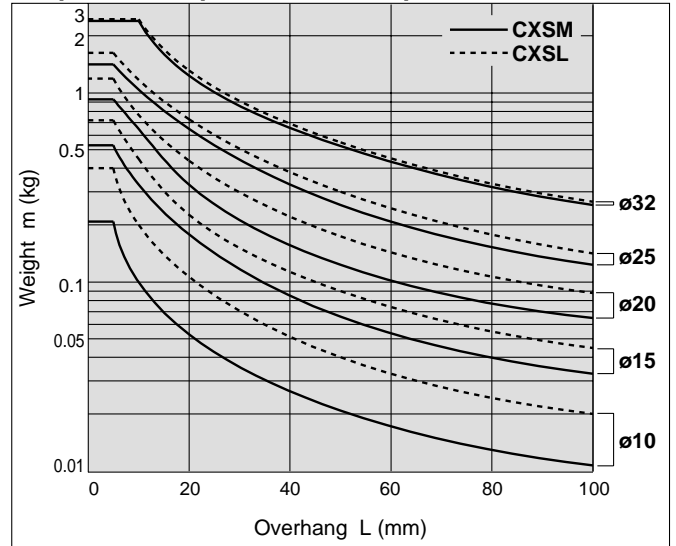

Graph 11 V = over 400mm/s; up to 10mm

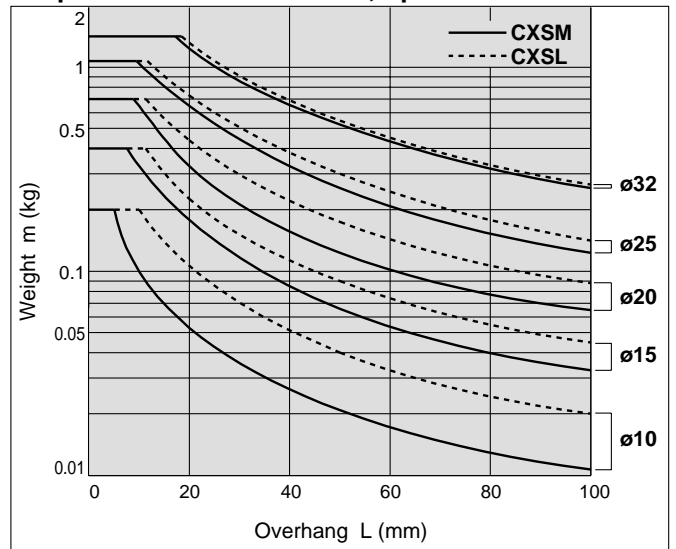

Graph 12 V = up to 400mm/s; up to 30mm

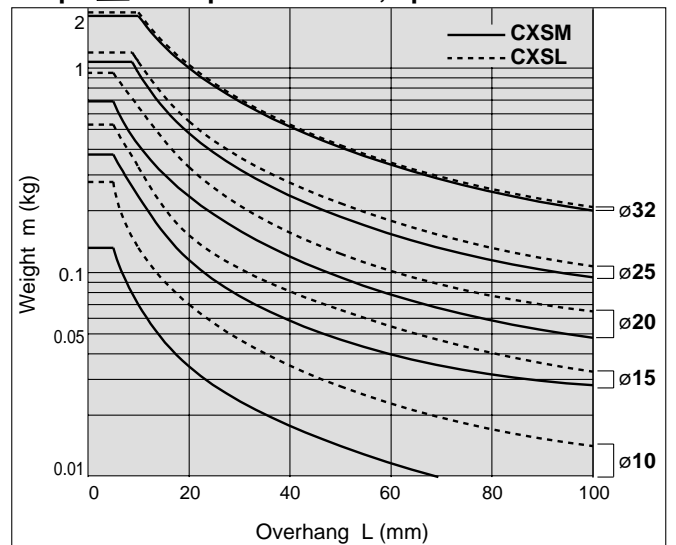

Compact Type
CXSJ

Standard Type
CXSL

With Air Cushion
CXSM

With End Lock
CXSL

Dual-Double-Rod Type
CXSM

Auto Switches

Made to Order

Precautions

Series CXS

Horizontal Mounting [based on maximum speed and stroke length]

ø10 to ø32

Graph 13 V = over 400mm/s; up to 30mm

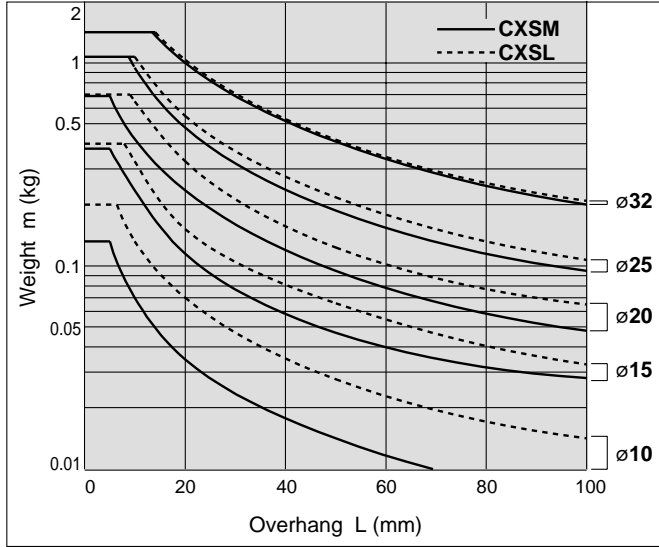

Graph 14 V = up to 400mm/s; up to 50mm

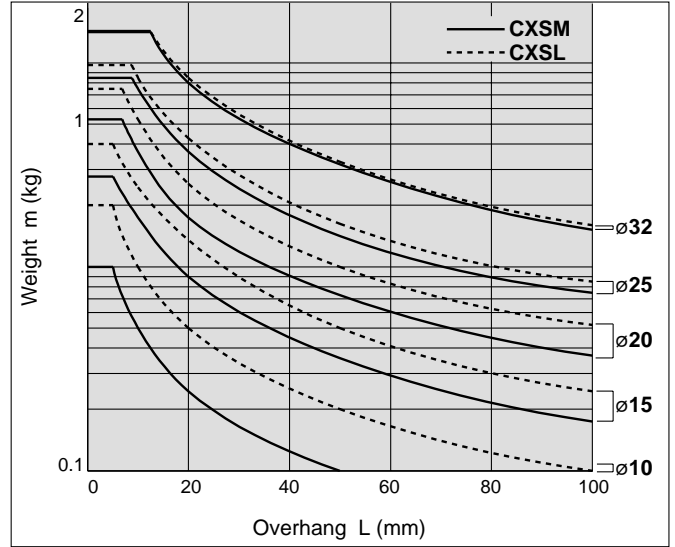

Graph 15 V = over 400mm/s; up to 50mm

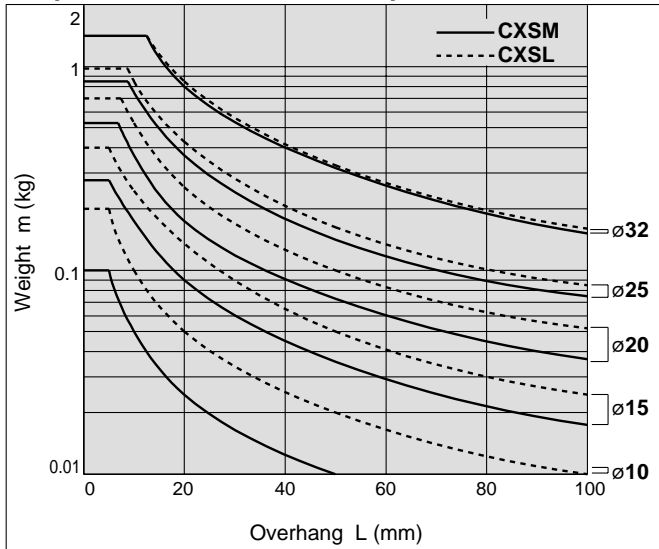

Graph 16 V = over 400mm/s; up to 75mm

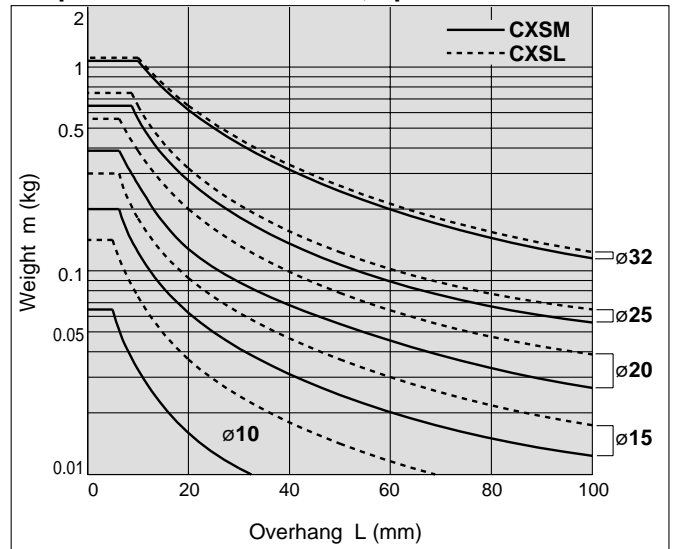

Graph 17 V = over 400mm/s; up to 100mm

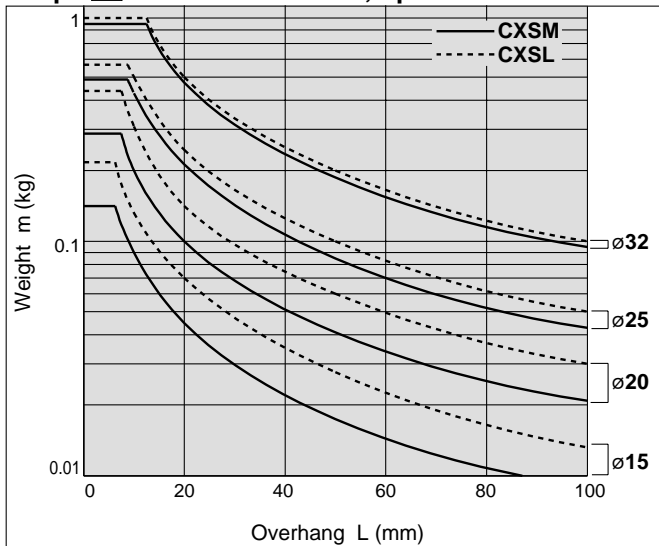

Series CXS

Model Selection

⚠ Caution Theoretical output must be confirmed separately, referring to the table on page 20.

With Air Cushion: CXS

Vertical mounting

Mounting orientation						
	Maximum speed (mm/s)	up to 200	up to 400	up to 600	up to 800	up to 1000
Stroke (mm)	All strokes					
Selection graph	∅20	1	2	3	4	5
	∅25					
	∅32					

Horizontal mounting

Mounting orientation							
	* Refer to the caution notes below.						
Stroke (mm)	up to 10		up to 30		up to 50	up to 75	up to 100
Maximum speed (mm/s)	up to 800	up to 1000	up to 800	up to 1000	up to 1000	up to 1000	up to 1000
Selection graph	∅20	6	7	8	9	10	11
	∅25						
	∅32						

⚠ Caution

If the cylinder is horizontally mounted and the plate end does not reach the load's centre of gravity, use the formula below to calculate the imaginary stroke L' that includes the distance between the load's centre of gravity and the plate end. Select the graph that corresponds to the imaginary stroke L' .

$$\text{Imaginary stroke } L' = (\text{Stroke}) + k + L$$

k: Distance between the centre and the end of the plate

∅20	6mm
∅25	
∅32	8mm

(Example)

When using CXSM20-10 and $L = 10\text{mm}$:

$$\text{Imaginary stroke } L' = 10 + 6 + 10 = 26$$

Therefore, the graph used for your model selection should be the one for CXSM20-30 (8, 9).

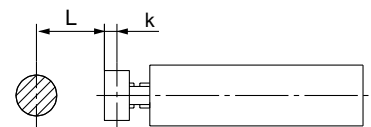

Compact Type CXSJ
Standard Type CXS
With Air Cushion CXS
With End Lock CXS
Dual-Rod Type CXSW
Auto Switches
Made to Order
Precautions

Series CXS

Vertical Mounting [based on maximum speed (V)]

Graph 1 V = up to 200mm/s

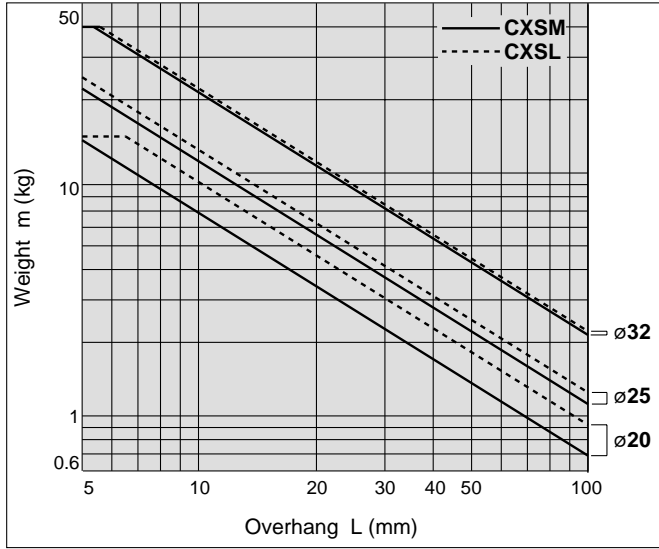

Graph 2 V = up to 400mm/s

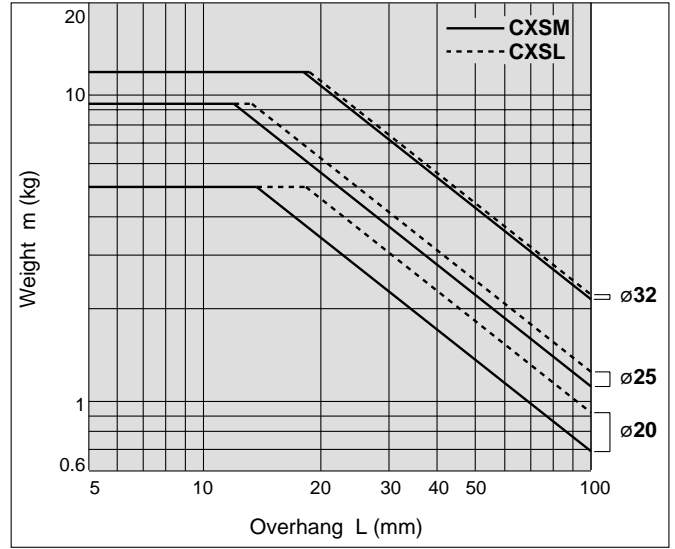

Graph 3 V = up to 600mm/s

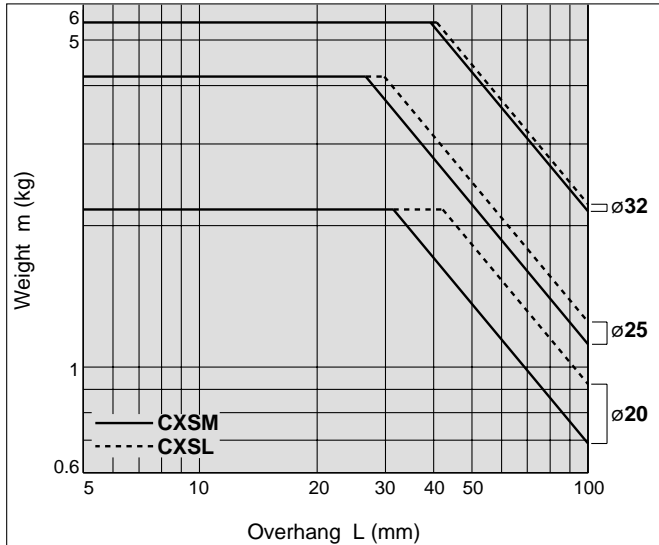

Graph 4 V = up to 800mm/s

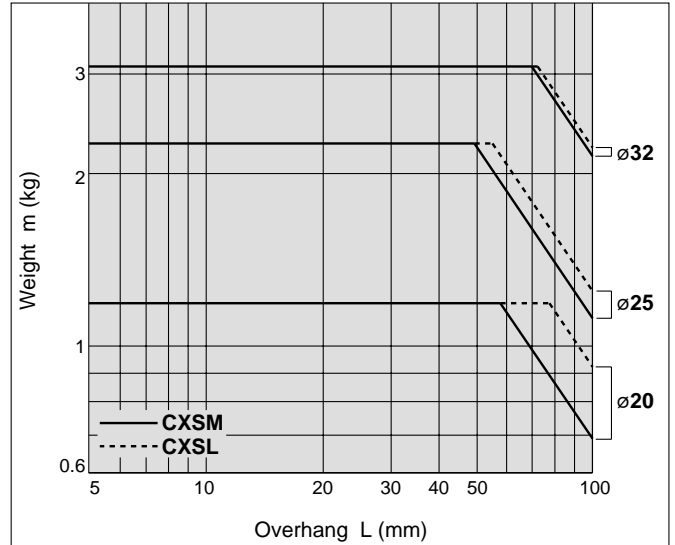

Graph 5 V = up to 1000mm/s

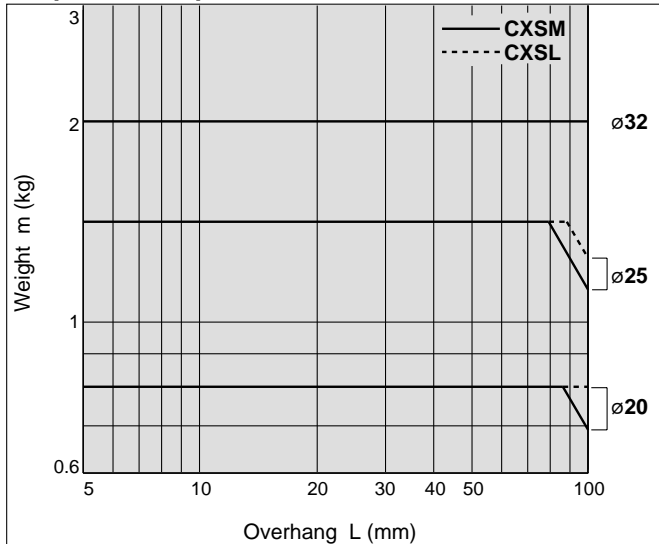

Horizontal Mounting [based on maximum speed and stroke length]

Graph 6 V = up to 800mm/s; up to 10mm

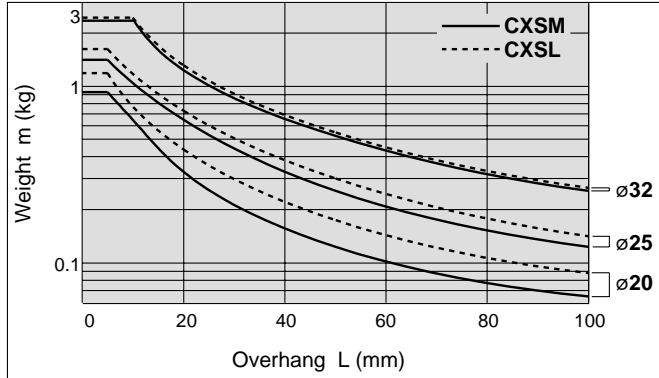

Graph 7 V = up to 1000mm/s; up to 10mm

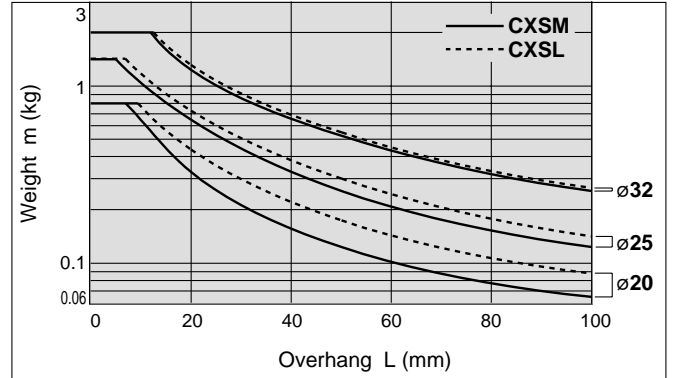

Graph 8 V = up to 800mm/s; up to 30mm

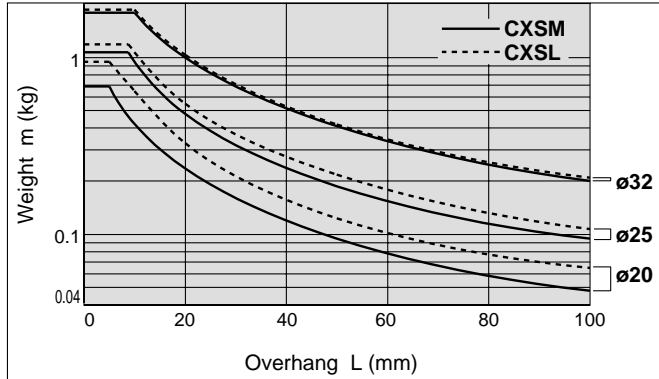

Graph 9 V = up to 1000mm/s; up to 30mm

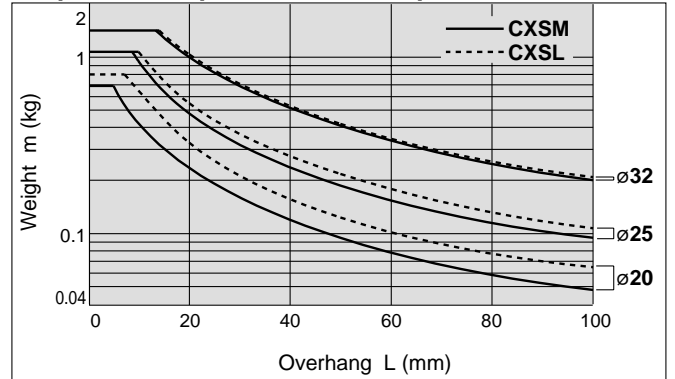

Graph 10 V = up to 1000mm/s; up to 50mm

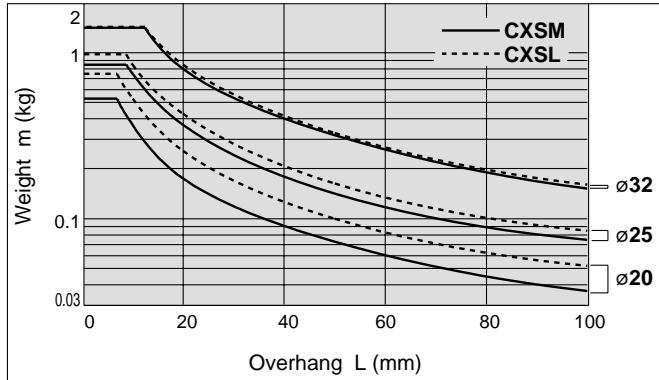

Graph 11 V = up to 1000mm/s; up to 75mm

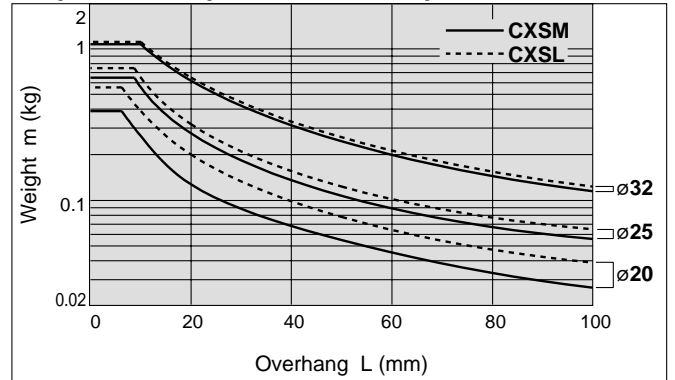

Graph 12 V = up to 1000mm/s; up to 100mm

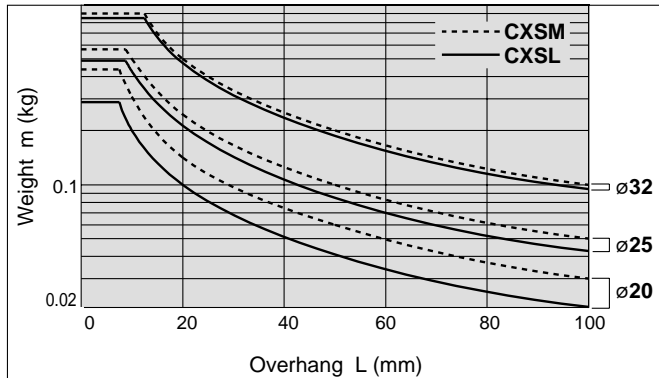

Compact Type
CXSL

Standard Type
CXSM

With Air Cushion
CXSL

With End Lock
CXSM

Dual-Double-Rod Type
CXSM

Auto Switches

Made to Order

Precautions



Series CXS

Safety Instructions

These safety instructions are intended to prevent a hazardous situation and/or equipment damage. These instructions indicate the level of potential hazard by a label of "**Caution**", "**Warning**", or "**Danger**". To ensure safety, be sure to observe ISO 4414 Note 1), JIS B 8370 Note 2) and other safety practices.

⚠ Caution : Operator error could result in injury or equipment damage.

⚠ Warning : Operator error could result in serious injury or loss of life.

⚠ Danger : In extreme conditions, there is a possible result of serious injury or loss of life.

Note 1) ISO 4414: Pneumatic fluid power – Recommendations for the application of equipment to transmission and control systems.

Note 2) JIS B 8370: General Rules for Pneumatic Equipment

⚠ Warning

1. The compatibility of pneumatic equipment is the responsibility of the person who designs the pneumatic system or decides its specifications.

Since the products specified here are used in various operating conditions, their compatibility with the specific pneumatic system must be based on specifications or after analysis and/or tests to meet your specific requirements.

2. Only trained personnel should operate pneumatically operated machinery and equipment.

Compressed air can be dangerous if an operator is unfamiliar with it. Assembly, handling, or repair of pneumatic systems should be performed by trained and experienced operators.

3. Do not service machinery/equipment or attempt to remove components until safety is confirmed.

1. Inspection and maintenance of machinery/equipment should only be performed after confirmation of safe locked-out control positions.

2. When equipment is to be removed, confirm the safety process as mentioned above. Cut the supply pressure for this equipment and exhaust all residual compressed air in the system.

3. Before machinery/equipment is restarted, take measures to prevent shooting-out of cylinder piston rod, etc. (Bleed air into the system gradually to create back pressure.)

4. Contact SMC if the product is to be used in any of the following conditions:

1. Conditions and environments beyond the given specifications, or if product is used outdoors.

2. Installation on equipment in conjunction with atomic energy, railway, air navigation, vehicles, medical equipment, food and beverages, recreation equipment, emergency stop circuits, press applications, or safety equipment.

3. An application which has the possibility of having negative effects on people, property, or animals, requiring special safety analysis.



Series CXS Actuator Precautions 1

Be sure to read before handling.

Design

⚠ Warning

1. **There is a danger of sudden or erratic action by cylinders if sliding parts of machinery are twisted and changes in forces occur.**

In such cases, bodily injury may occur, e.g., by catching hands or feet in the machinery, or damage to the machinery itself may occur. Therefore, the machinery should be adjusted to operate smoothly and designed to prevent such dangers.

2. **A protective cover is recommended to minimize the risk of bodily injury.**

If a driven object and moving parts of a cylinder pose a serious danger of bodily injury, design the structure to avoid contact with the human body.

3. **Securely tighten all stationary parts and connected parts so that they will not become loose.**

Especially when a cylinder operates with high frequency or is installed where there is a lot of vibration, ensure that all parts remain secure.

4. **A deceleration circuit or shock absorber may be required.**

When a driven object is operated at high speed or the load is heavy, a cylinder's cushion will not be sufficient to absorb impact. Install a deceleration circuit to reduce the speed before cushioning, or install an external shock absorber to relieve impact. In this case, the rigidity of the machinery should also be examined.

5. **Take into account a possible drop in operating pressure due to a power outage.**

When a cylinder is used as a clamping mechanism, there is a danger of work pieces dropping if there is a decrease in clamping force due to a drop in circuit pressure caused by a power outage. Therefore, safety equipment should be installed to prevent damage to machinery and bodily injury. Suspension mechanisms and lifting devices also require drop prevention measures.

6. **Take into account a possible loss of power source.**

Measures should be taken to protect against bodily injury and equipment damage in the event that there is a loss of power to equipment controlled by air pressure, electricity, or hydraulics.

7. **Design circuitry to prevent sudden lurching of driven objects.**

Take special care when a cylinder is operated by an exhaust centre type directional control valve or when it is starting up after residual pressure is exhausted from the circuit. The piston and its driven object will lurch at high speed if pressure is applied to one side of the cylinder because of the absence of air pressure inside the cylinder. Therefore, equipment should be selected and circuits designed to prevent sudden lurching because when this occurs, there is a danger of bodily injury, particularly to limbs, and/or damage to equipment.

8. **Take into account emergency stops.**

Design the system so that bodily injury and/or damage to machinery and equipment will not occur when machinery is stopped by a manual emergency stop or a safety device triggered by abnormal conditions.

9. **Consider a system's action when operation is restarted after an emergency or abnormal stop.**

Design machinery so that bodily injury or equipment damage will not occur upon restart of operation.

When the cylinder has to be reset at the starting position, install safe manual control equipment.

Selection

⚠ Warning

1. **Confirm the specifications.**

The products featured in this catalog are designed for use in industrial compressed air systems. If the products are used in conditions where pressure and/or temperature are outside the range of specifications, damage and/or malfunction may occur. Do not use in these conditions. (Refer to specifications.)

Consult with SMC if fluid other than compressed air is to be used.

2. **Intermediate stops**

When intermediate stopping of a cylinder piston is performed with a 3-position closed centre type directional control valve, it is difficult to achieve stopping positions as accurately and precisely as with hydraulic pressure due to the compressibility of air.

Furthermore, since valves and cylinders are not guaranteed for zero air leakage, it may not be possible to hold a stopped position for an extended period of time. Contact SMC if it is necessary to hold a stopped position for an extended period.

⚠ Caution

1. **Operate within the limits of the maximum usable stroke.**

The piston rod will be damaged if operated beyond the maximum stroke. Refer to the cylinder model selection procedure for the maximum usable stroke.

2. **Operate the piston in such a way that collision damage will not occur at the stroke end.**

The operation range should prevent damage from occurring when a piston, having inertial force, stops by striking the cover at the stroke end. Refer to the cylinder model selection procedure for the maximum usable stroke.

3. **Use a speed controller to adjust the cylinder drive speed, gradually increasing from a low speed to the desired speed setting.**

Piping

⚠ Caution

1. **Preparation before piping**

Before piping is connected, it should be thoroughly flushed out with air or water to remove chips, cutting oil, and other debris.

2. **Wrapping of sealant tape**

When screwing together pipes and fittings, be certain that chips from the pipe threads and sealing material do not get inside the piping.

Also, when sealant tape is used, leave 1.5 to 2 thread ridges exposed at the end of the threads.

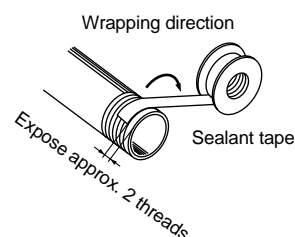



Series CXS

Actuator Precautions 2

Be sure to read before handling.

Mounting

Caution

1. **Do not scratch or gouge the cylinder tube or the sliding parts of the piston rod by striking or grasping them with other objects.**

Cylinder bores are manufactured to precise tolerances, so that even a slight deformation may cause faulty operation.

Also, scratches or gouges in the piston rod may lead to damaged seals and cause air leakage.

2. **When attaching and tightening a work piece to the end of the plate, the plate should be secured while the piston rod is fully retracted to avoid excessive torque applied to the piston rod.**

3. **Do not use until you can verify that equipment can operate properly.**

Following mounting, repairs, or conversions, verify correct mounting by conducting suitable function and leakage tests after piping and power connections have been made.

4. **Instruction manual**

The product should be mounted and operated after thoroughly reading the manual and understanding its contents.

Keep the instruction manual where it can be readily referred to as needed.

Cushion

Caution

1. **Readjust using the cushion needle.**

Cushion needles are adjusted at the time of shipment. When the cylinder is put into service, the cushion needles on the housing should be readjusted based on factors such as the size of the load and the operating speed. When the cushion needles are turned clockwise, restriction of the air flow becomes greater and thus the cushioning effect also increases.

2. **Do not operate with the cushion needles fully closed.**

Seals may be damaged.

Lubrication

Caution

1. **Lubrication of non-lube type cylinder**

The cylinder is lubricated for life at the factory and can be used without any further lubrication.

However, in the event that additional cylinder lubrication is required, be sure to use ISO VG32 Class 1 turbine oil (with no additives).

Stopping lubrication later may lead to malfunctions because the new lubricant will cancel out the original lubricant. Therefore, additional lubrication must be continued once it has been started.

Air Supply

Warning

1. **Use clean air.**

Do not use compressed air containing chemicals, synthetic oils containing organic solvents, salt, or corrosive gases, as this can cause damage or malfunctions.

Air Supply

Caution

1. **Install air filters.**

Install air filters immediately upstream of valves. The filtration degree should be 5µm or finer.

2. **Install an after-cooler, air dryer, or water separator (Drain Catch).**

Air that includes excessive drainage or condensate may cause malfunction of valves and other pneumatic equipment. To prevent this, install an after-cooler, air dryer, or water separator (Drain Catch).

3. **Use the product within the specified range of fluid and ambient temperature.**

Take measures to prevent freezing when below 5°C, since moisture in circuits can freeze and cause damage to seals and lead to malfunctions.

Refer to SMC's "Air Preparation System" catalog for further details on compressed air quality.

Operating Environment

Warning

1. **Do not use in environments where there is a danger of corrosion.**

Refer to the construction drawings regarding cylinder materials.

2. **In dusty locations or where water or oil splashing is a regular occurrence, protect the rod by installing a rod cover.**

In dusty locations, use a coil scraper type (available through special order). When there is splashing or spraying of liquid, use a water-resistant cylinder (available through special order).

3. **When using auto switches, do not operate in an environment where there are strong magnetic fields.**

Maintenance

Warning

1. **Perform maintenance inspection and service according to the procedures indicated in the instruction manual.**

Improper handling and maintenance may cause malfunctioning and damage of machinery or equipment to occur.

2. **Removal of components, and supply/exhaust of compressed air**

Before any machinery or equipment is removed, first ensure that the appropriate measures are in place to prevent the fall or erratic movement of driven objects and equipment, then cut off the electric power and reduce the pressure in the system to zero. Only then should you proceed with the removal of any machinery and equipment.

When machinery is restarted, proceed with caution after confirming that appropriate measures are in place to prevent cylinders from lurching.

Caution

1. **Filter drainage**

Drain out condensate from air filters regularly.



Series CXS Specific Product Precautions

Be sure to read before handling.

Mounting

⚠ Caution

1. Make sure that the surface on which the cylinder is to be mounted is flat (reference value for flatness: 0.05 or less).

Dual-rod cylinders can be mounted from 3 directions, however, make sure that the surface on which the cylinder is to be mounted is flat (reference value for flatness: 0.5 or less). Otherwise, the accuracy of the piston rod operation is not achieved, and malfunctioning can occur.

2. The piston rod must be retracted when mounting the cylinder.

Scratches or gouges in the piston rod may lead to damaged bearings and seals and cause malfunctions or air leakage.

3. CXSJ

Adjust the bolt holder using a hexagon wrench 3mm in width across flats so that it does not protrude from the cylinder surface (approx. 0.5mm depth from the cylinder surface to the top of the holder). If the bolt holder is not properly adjusted, it can interfere with the switch rail, hindering the auto switch mounting. The required length of the mounting bolt for a bolt holder and mounting hole in the rod cover side varies depending on the bearing surface position for the mounting bolt. Refer to dimensions L₁ and L₂ provided below to select the appropriate mounting bolt length.

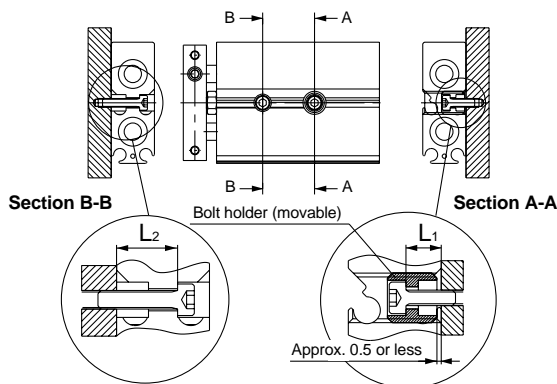

	L ₁ (mm)	L ₂ (mm)
CXSJ□6	5	8.4
CXSJ□10	5	9.5

Piping

1. Plug the appropriate supply port(s) according to the operating conditions.

Dual-rod cylinders have 2 supply ports for each operating direction (3 supply ports for ø6 only). Plug the appropriate supply port according to the operating conditions. However, when switching the plugged port, verify air leakage. If small air leakage is detected, unplug the port, check the seat surface, and reassemble it.

2. CXSJ

For axial piping, the side port of the standard cylinder is plugged. However, a plugged port can be switched according to the operating conditions. When switching the plugged port, check for air leakage. If small air leakage is detected, unplug the port, check the seat surface, and reassemble it.

Stroke Adjustment

⚠ Caution

1. After adjusting the stroke, make sure to tighten the hexagon nut to prevent it from loosening.

Dual-rod cylinders have a bolt to adjust 0 to -5mm strokes on the retracted end (IN).

Loosen the hexagon nut to adjust the stroke; however, make sure to tighten the hexagon nut after making an adjustment.

2. Never operate a cylinder with its bumper bolt removed. Also, do not attempt to tighten the bumper bolt without using a nut.

If the bumper bolt is removed, the piston hits the head cover causing damage to the cylinder. Therefore, do not use a cylinder without a bumper bolt.

Furthermore, if the bumper bolt is tightened without a nut, the piston seal is caught in the leveled part, damaging the seal.

3. A bumper at the end of the bumper bolt is replaceable.

In case a missing bumper, or a bumper has a permanent settling, use a following part numbers for ordering.

Bore size (mm)	6, 10, 15	20, 25	32
Part no.	CXS10-34A 28747	CXS20-34A 28749	CXS32-34A 28751
No. of bumpers	1		

Disassembly and Maintenance

⚠ Caution

1. Never use a cylinder with its plate removed.

When removing the hexagon socket head cap screw on the end plate, the piston rod must be secured to prevent from rotating. However, if the sliding parts of the piston rod are scratched and gouged, a malfunction may occur. If the plate is not required for your applications, use the cylinder that does not come with a plate, available through Made to Order (-X593) on page 53.

2. When disassembling and reassembling the cylinder, contact SMC or refer to the separate instruction manual.

⚠ Warning

1. Take precautions when your hands are near the plate and housing.

When the cylinder is operated, take extra precautions to avoid getting your hands and fingers caught between the plate and housing, that can cause a bodily injury.



Series CXS

Auto Switch Precautions 1

Be sure to read before handling.

Design and Selection

⚠ Warning

1. Confirm the specifications.

Read the specifications carefully and use the product appropriately. The product may be damaged or malfunction if it is used outside the range of specifications for load current, voltage, temperature, or impact.

2. Take precautions when multiple cylinders are used close together.

When two or more auto switch cylinders are lined up in close proximity to each other, magnetic field interference may cause the switches to malfunction. Maintain a minimum cylinder separation of 40mm. (When the allowable interval is specified for each cylinder series, use the indicated value.)

3. Monitor the length of time that a switch is ON at an intermediate stroke position.

When an auto switch is placed at an intermediate position of the stroke and a load is driven at the time the piston passes, the auto switch will operate, but if the speed is too great the operating time will be shortened and the load may not operate properly. The maximum detectable piston speed is:

$$V(\text{mm/s}) = \frac{\text{Auto switch operating range (mm)}}{\text{Load operating time (ms)}} \times 1000$$

4. Keep wiring as short as possible.

<Reed switches>

As the length of the wiring to a load gets longer, the rush current at switching ON becomes greater, and this may shorten the product's life. (The switch will stay ON all the time.)

- 1) For an auto switch without a contact protection circuit, use a contact protection box when the wire length is 5m or longer.

<Solid state switches>

- 2) Although wire length should not affect switch function, use a wire that is 100m or shorter.

5. Monitor the internal voltage drop of the switch.

<Reed switches>

- 1) Switches with an indicator light (except D-Z76, D-A96, D-A96V)

- If auto switches are connected in series as shown below, take note that there will be a large voltage drop because of internal resistance in the light emitting diodes. (Refer to internal voltage drop in the auto switch specifications.)

[The voltage drop will be "n" times larger when "n" auto switches are connected.]

Even though an auto switch operates normally, the load may not operate.

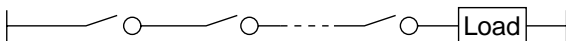

- Similarly, when operating below a specified voltage, it is possible that the load may be ineffective even though the auto switch function is normal. Therefore, the formula below should be satisfied after confirming the minimum operating voltage of the load.

$$\text{Supply voltage} - \text{Internal voltage drop of switch} > \text{Minimum operating voltage of load}$$

- 2) If the internal resistance of a light emitting diode causes a problem, select a switch without an indicator light (D-Z80, D-A90, D-A90V).

<Solid state switches>

- 3) Generally, the internal voltage drop will be greater with a 2-wire solid state auto switch than with a reed switch. Take the same precautions as in 1) above.

Also note that a 12VDC relay is not applicable.

6. Monitor leakage current.

<Solid state switches>

With a 2-wire solid state auto switch, current (leakage current) flows to the load to operate the internal circuit even when in the OFF state.

If the condition given in the below formula is not met, the switch will not reset correctly (it stays ON).

$$\text{Current to operate load (OFF condition)} > \text{Leakage current}$$

Use a 3-wire switch if this condition cannot be satisfied. Moreover, leakage current flow to the load will be "n" times larger when "n" auto switches are connected in parallel.

7. Do not use a load that generates surge voltage.

<Reed switches>

If driving a load that generates surge voltage, such as a relay, use a switch with a built-in contact protection circuit or a contact protection box.

<Solid state switches>

Although a zener diode for surge protection is connected at the output side of a solid state auto switch, damage may still occur if a surge is applied repeatedly. When directly driving a load that generates surge, such as a relay or solenoid valve, use a switch with a built-in surge absorbing element.

8. Cautions for use in an interlock circuit

When an auto switch is used for an interlock signal requiring high reliability, devise a double interlock system to safeguard against malfunctions by providing a mechanical protection function, or by also using another switch (sensor) together with the auto switch.

Also perform periodic maintenance inspections and confirm proper operation.

9. Ensure sufficient clearance for maintenance activities.

When designing an application, be sure to allow sufficient clearance for maintenance and inspections.



Series CXS Auto Switch Precautions 2

Be sure to read before handling.

Mounting and Adjustment

Warning

1. Do not drop or bump.

Do not drop, bump, or apply excessive impacts (300m/s² or more for reed switches and 1000m/s² or more for solid state switches) while handling. Although the body of the switch may not be damaged, the inside of the switch could be damaged and cause a malfunction.

2. Do not carry a cylinder by the auto switch lead wires.

Never carry a cylinder by its lead wires. This may not only cause broken lead wires, but it may cause internal elements of the switch to be damaged by the stress.

3. Mount switches using the proper tightening torque.

When a switch is tightened beyond the range of tightening torque, the mounting screws or switch may be damaged.

On the other hand, tightening below the range of tightening torque may allow the switch to slip out of position.

4. Mount a switch at the center of the operating range.

Adjust the mounting position of an auto switch so that the piston stops at the center of the operating range (the range in which a switch is ON). (The mounting positions shown in the catalog indicate the optimum position at the stroke end.) If mounted at the end of the operating range (around the borderline of ON and OFF), the operation will be unstable.

Wiring

Warning

1. Avoid repeatedly bending or stretching lead wires.

Broken lead wires will result from repeatedly applying bending stress or stretching force to the lead wires.

2. Be sure to connect the load before power is applied.

<2-wire type>

If the power is turned on when an auto switch is not connected to a load, the switch will be instantly damaged because of excess current.

3. Confirm proper insulation of wiring.

Be certain that there is no faulty wiring insulation (such as contact with other circuits, ground fault, improper insulation between terminals). Damage may occur due to excess current flow into a switch.

4. Do not wire in conjunction with power lines or high voltage lines.

Wire separately from power lines or high voltage lines, avoiding parallel wiring or wiring in the same conduit with these lines. Control circuits containing auto switches may malfunction due to noise from these other lines.

Wiring

Warning

5. Do not allow short circuiting of loads.

<Reed switches>

If the power is turned on with a load in a short circuited condition, the switch will be instantly damaged because of excess current flow into the switch.

<Solid state switches>

D-F9□(V), D-F9□W(V) and PNP output type switches do not have built-in short circuit protection circuits. If loads are short circuited, the switches will be instantly damaged, as in the case of reed switches.

Take special care to avoid reverse wiring with the brown [red] power supply line and the black [white] output line on 3-wire type switches.

6. Avoid incorrect wiring.

<Reed switches>

A 24VDC switch with indicator light has polarity. The brown [red] lead wire is (+), and the blue [black] lead wire is (-).

1) If connections are reversed, the switch will still operate, but the light emitting diode will not light up.

Also note that a current greater than the maximum specified one will damage a light emitting diode and make it inoperable.

Applicable models: D-A93, D-A93V, D-Z73

<Solid state switches>

1) Even if connections are reversed on a 2-wire type switch, the switch will not be damaged because it is protected by a protection circuit, but it will remain in a normally ON state. However, it is still necessary to avoid reversed connections since the switch will be damaged if a load short circuits in this condition.

2) Even if (+) and (-) power supply line connections are reversed on a 3-wire type switch, the switch will still be protected by a protection circuit. However, if the (+) power supply line is connected to the blue [black] wire and the (-) power supply line is connected to the black [white] wire, the switch will be damaged.

* Lead wire colour changes

Lead wire colours of SMC switches have been changed in order to meet NECA Standard 0402 for production beginning September, 1996 and thereafter. Please refer to the tables provided. Special care should be taken regarding wire polarity during the time that the old colours still coexist with the new colours.

2-wire			3-wire		
	Old	New		Old	New
Output (+)	Red	Brown	Power supply (+)	Red	Brown
Output (-)	Black	Blue	Power supply GND	Black	Blue
			Output	White	Black
Solid state with diagnostic output			Solid state with latch type diagnostic output		
	Old	New		Old	New
Power supply (+)	Red	Brown	Power supply (+)	Red	Brown
Power supply GND	Black	Blue	Power supply GND	Black	Blue
Output	White	Black	Output	White	Black
Diagnostic output	Yellow	Orange	Latch type diagnostic output	Yellow	Orange



Series CXS

Auto Switch Precautions 3

Be sure to read before handling.

Operating Environment

Warning

1. Never use in the presence of explosive gases.

The construction of our auto switches does not make them explosion-proof. Never use them in the presence of an explosive gas, as this may cause a serious explosion

2. Do not use in an area where a magnetic field is generated.

Auto switches will malfunction or magnets inside cylinders will become demagnetized if used in such an environment.

3. Do not use in an environment where the auto switch will be continually exposed to water.

Auto switches satisfy IEC standard IP67 construction (JIS C0920: watertight construction). Nevertheless, they should not be used in applications where they are continually exposed to water splash or spray. This may cause deterioration of the insulation or swelling of the potting resin inside switches and may lead to a malfunction.

4. Do not use in an environment laden with oil or chemicals.

Consult with SMC if auto switches will be used in an environment laden with coolants, cleaning solvents, various oils, or chemicals. If auto switches are used under these conditions for even a short time, they may be adversely affected by a deterioration of the insulation, a malfunction due to swelling of the potting resin, or hardening of the lead wires.

5. Do not use in an environment with temperature cycles.

Consult with SMC if switches are to be used where there are temperature cycles other than normal temperature changes, as they may be adversely affected internally.

6. Do not use in an environment where there is excessive impact shock.

<Reed switches>

When excessive impact (300m/s² or more) is applied to a reed switch during operation, the contact point may malfunction and generate or cut off a signal momentarily (1ms or less). Consult with SMC regarding the need to use a solid state switch depending on the environment.

7. Do not use in an area where surges are generated.

<Solid state switch>

When there are units (such as solenoid type lifters, high frequency induction furnaces, motors) that generate a large amount of surge in the area around cylinders with solid state auto switches, their proximity may cause deterioration or damage to the internal circuit elements of the switches. Avoid and protect against sources of surge generation and crossed lines.

8. Avoid close contact with accumulated iron waste or magnetic substances.

When a large accumulated amount of ferrous waste such as machining chips or welding spatter, or a magnetic substance (something attracted by a magnet) is brought into close proximity to an cylinder with auto switches, this may cause the auto switches to malfunction due to a loss of the magnetic force inside the cylinder.

Maintenance

Warning

1. Perform the following maintenance inspection and services periodically in order to prevent possible danger due to unexpected auto switch malfunction.

1) Securely tighten switch mounting screws.

If screws become loose or the mounting position is dislocated, retighten screws securely after readjusting the mounting position.

2) Confirm that there is no damage to lead wires.

To prevent faulty insulation, replace switches or repair lead wires if damage is discovered.

3) Confirm that the green light on the 2-color indicator type switch lights up.

Confirm that the Green LED is ON when stopped at the set position. If the Red LED is ON when stopped at the set position, the mounting position is not appropriate. Readjust the mounting position until the Green LED lights up.

Other

Warning

1. Consult with SMC concerning water resistance, elasticity of lead wires, and usage at welding sites.