

- 1
- 2
- 3
- 4
- 5
- 6
- 7
- 8
- 9
- 10
- 11
- 12
- 13
- 14
- 15
- 16
- 17
- 18

THREADED BODY AND LOCKING NUT

Black-oxide steel.

PLUNGER

Nickel-plated AISI 303 stainless steel.

Suggested tolerance for matching hole = H7.

KNOB

High-resilience polyamide based (PA) technopolymer, black colour, matte finish.

STANDARD EXECUTIONS

- **GN 313-A-ST**: with knob, without locking nut.
- **GN 313-AK-ST**: with knob, with locking nut.
- **GN 313-D-ST**: without knob, without locking nut.
- **GN 313-DK-ST**: without knob, with locking nut.
- **index 1**: for plunger without internal threading.
- **index 2**: for plunger with internal threading.

FEATURES AND APPLICATIONS

GN 313 indexing plungers have fully retracted plunger out of gear. By using the execution with internal threaded plunger (index 2), special devices may operate by means of threaded rods.

GN 313-D and GN 313-DK are without knob for operating by means of pneumatic cylinders, helical cams, etc.



GN 313-A-ST
GN 313-AK-ST

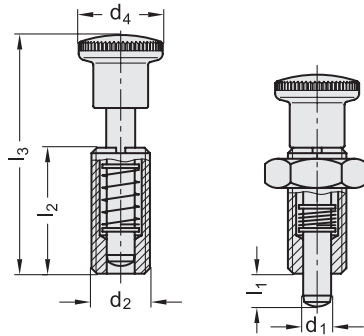

GN 313-..-2

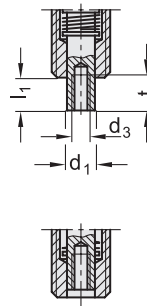

Code	Description	d1 Plunger -0.02-0.04 Hole H7	d2	d3	d4	l1	l2	l3	t	Spring preload [N]	Spring max load [N]	Δt
GN.14999	GN 313-5-A-1-ST	5	M10x1	-	16	6	22	42	-	8	20	12
GN.15000	GN 313-5-A-2-ST	5	M10x1	M3	16	6	22	42	7	8	20	13
GN.15001	GN 313-6-A-1-ST	6	M12x1.5	-	19	7	26	49	-	9	28	18
GN.15002	GN 313-6-A-2-ST	6	M12x1.5	M4	19	7	26	49	7	9	28	20
GN.15003	GN 313-8-A-1-ST	8	M16x1.5	-	23	9	34	65	-	12	40	47
GN.15004	GN 313-8-A-2-ST	8	M16x1.5	M5	23	9	34	65	9	12	40	48
GN.15005	GN 313-10-A-1-ST	10	M20x1.5	-	28	11	43	78	-	22	50	70
GN.15006	GN 313-10-A-2-ST	10	M20x1.5	M6	28	11	43	78	12	22	50	75
GN.15019	GN 313-5-AK-1-ST	5	M10x1	-	16	6	22	42	-	8	20	15
GN.15020	GN 313-5-AK-2-ST	5	M10x1	M3	16	6	22	42	7	8	20	16
GN.15021	GN 313-6-AK-1-ST	6	M12x1.5	-	19	7	26	49	-	9	28	21
GN.15022	GN 313-6-AK-2-ST	6	M12x1.5	M4	19	7	26	49	7	9	28	23
GN.15023	GN 313-8-AK-1-ST	8	M16x1.5	-	23	9	34	65	-	12	40	66
GN.15024	GN 313-8-AK-2-ST	8	M16x1.5	M5	23	9	34	65	9	12	40	67
GN.15025	GN 313-10-AK-1-ST	10	M20x1.5	-	28	11	43	78	-	22	50	78
GN.15026	GN 313-10-AK-2-ST	10	M20x1.5	M6	28	11	43	78	12	22	50	80

Indexing and positioning elements

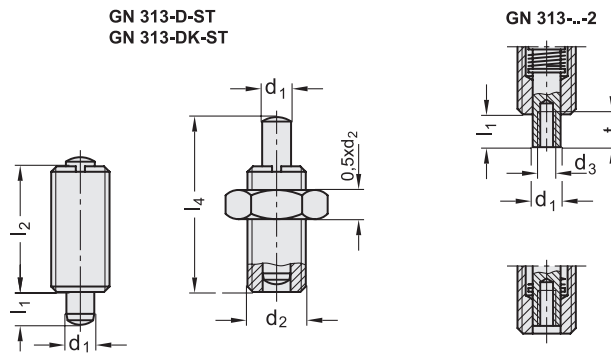

Code	Description	d1 Plunger -0.02-0.04 Hole H7	d2	d3	l1	l2	l4	t	Spring preload [N]	Spring max load [N]	
GN.15009	GN 313-5-D-1-ST	5	M10x1	-	6	22	29	-	8	20	16
GN.15010	GN 313-5-D-2-ST	5	M10x1	M3	6	22	29	7	8	20	17
GN.15011	GN 313-6-D-1-ST	6	M12x1.5	-	7	26	35	-	9	28	22
GN.15012	GN 313-6-D-2-ST	6	M12x1.5	M4	7	26	35	7	9	28	22
GN.15013	GN 313-8-D-1-ST	8	M16x1.5	-	9	34	48	-	12	40	43
GN.15014	GN 313-8-D-2-ST	8	M16x1.5	M5	9	34	48	9	12	40	42
GN.15015	GN 313-10-D-1-ST	10	M20x1.5	-	11	43	57	-	22	50	83
GN.15016	GN 313-10-D-2-ST	10	M20x1.5	M6	11	43	57	12	22	50	83
GN.15029	GN 313-5-DK-1-ST	5	M10x1	-	6	22	29	-	8	20	19
GN.15030	GN 313-5-DK-2-ST	5	M10x1	M3	6	22	29	7	8	20	20
GN.15031	GN 313-6-DK-1-ST	6	M12x1.5	-	7	26	35	-	9	28	25
GN.15032	GN 313-6-DK-2-ST	6	M12x1.5	M4	7	26	35	7	9	28	30
GN.15033	GN 313-8-DK-1-ST	8	M16x1.5	-	9	34	48	-	12	40	45
GN.15034	GN 313-8-DK-2-ST	8	M16x1.5	M5	9	34	48	9	12	40	50
GN.15035	GN 313-10-DK-1-ST	10	M20x1.5	-	11	43	57	-	22	50	85
GN.15036	GN 313-10-DK-2-ST	10	M20x1.5	M6	11	43	57	12	22	50	85