

UG479: BB51 Pro Kit User's Guide

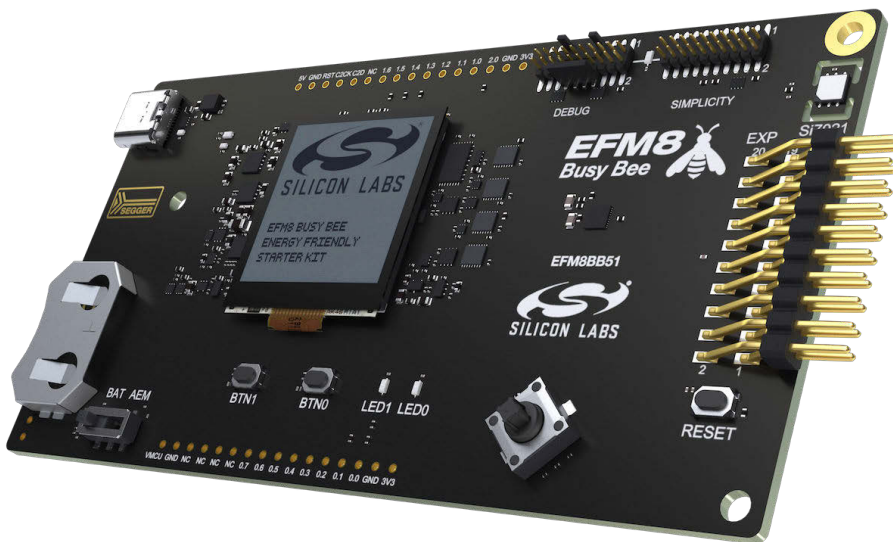

The BB51 Pro Kit is an excellent starting point to become familiar with the EFM8BB51™ Busy Bee Microcontroller.

The pro kit contains sensors and peripherals demonstrating some of the EFM8BB51's many capabilities. The kit provides all necessary tools for developing an EFM8BB51 Busy Bee application.



TARGET DEVICE

- EFM8BB51 Busy Bee Microcontroller (EFM8BB51F16I-C-QFN20)
- CPU: 8-bit CIP-51 8051 Core
- Memory: 16 kB flash and 1 kB RAM
- Oscillators: 49 MHz, 10 MHz, and 80 kHz

KIT FEATURES

- USB connectivity
- Advanced Energy Monitor (AEM)
- SEGGER J-Link on-board debugger
- Debug Multiplexer supporting external hardware as well as on-board MCU
- User push buttons and LEDs
- Silicon Labs' Si7021 Relative Humidity and Temperature Sensor
- Ultra-low power 128x128 pixel Memory LCD
- 8-direction analog joystick
- 20-pin 2.54 mm header for expansion boards
- Breakout pads for direct access to I/O pins
- Power sources include USB and CR2032 coin cell battery

SOFTWARE SUPPORT

- Simplicity Studio™

Table of Contents

1. Introduction	4
1.1 Description	4
1.2 Features	4
1.3 Getting Started	4
2. Kit Block Diagram	5
3. Kit Hardware Layout	6
4. Connectors	7
4.1 Breakout Pads	7
4.2 EXP Header	9
4.3 Debug Connector (DBG)	11
4.4 Simplicity Connector	12
5. Power Supply and Reset	13
5.1 MCU Power Selection	13
5.2 Board Controller Power	13
5.3 EFM8BB51 Reset	14
6. Peripherals	15
6.1 Push Buttons and LEDs	15
6.2 Joystick	16
6.3 Memory LCD-TFT Display	17
6.4 Si7021 Relative Humidity and Temperature Sensor	18
6.5 Virtual COM Port	19
7. Advanced Energy Monitor	20
7.1 Usage	20
7.2 Theory of Operation	20
7.3 Accuracy and Performance	20
8. On-Board Debugger	21
8.1 Debug Modes	22
8.2 Debugging During Battery Operation	23
9. Kit Configuration and Upgrades	24
9.1 Firmware Upgrades	24
10. Schematics, Assembly Drawings, and BOM	25
11. Kit Revision History and Errata	26
11.1 Revision History	26
11.2 Errata	26

12. Document Revision History **.27**

1. Introduction

1.1 Description

The BB51 Pro Kit is an ideal starting point for application development on the EFM8BB51 Busy Bee Microcontrollers. The board features sensors and peripherals, demonstrating some of the many capabilities of the EFM8BB51 Busy Bee Microcontroller. Additionally, the board is a fully featured debugger and energy monitoring tool that can be used with external applications.

1.2 Features

- EFM8BB51 Busy Bee Microcontroller
 - 16 kB Flash
 - 1 kB RAM
 - QFN20 package
- Advanced Energy Monitoring system for precise current and voltage tracking
- Integrated Segger J-Link USB debugger/emulator with the possibility to debug external Silicon Labs devices
- 20-pin expansion header
- Breakout pads for easy access to I/O pins
- Power sources include USB and CR2032 battery
- Silicon Labs' Si7021 Relative Humidity and Temperature Sensor
- Ultra-low power 128x128 pixel Memory-LCD
- 2 push buttons and 2 LEDs connected to EFM8 for user interaction
- 8-direction analog joystick for user interaction

1.3 Getting Started

Detailed instructions for how to get started with your new BB51 Pro Kit can be found on the Silicon Labs Web pages:

silabs.com/development-tools/mcu/8-bit

2. Kit Block Diagram

An overview of the BB51 Pro Kit is shown in the figure below.

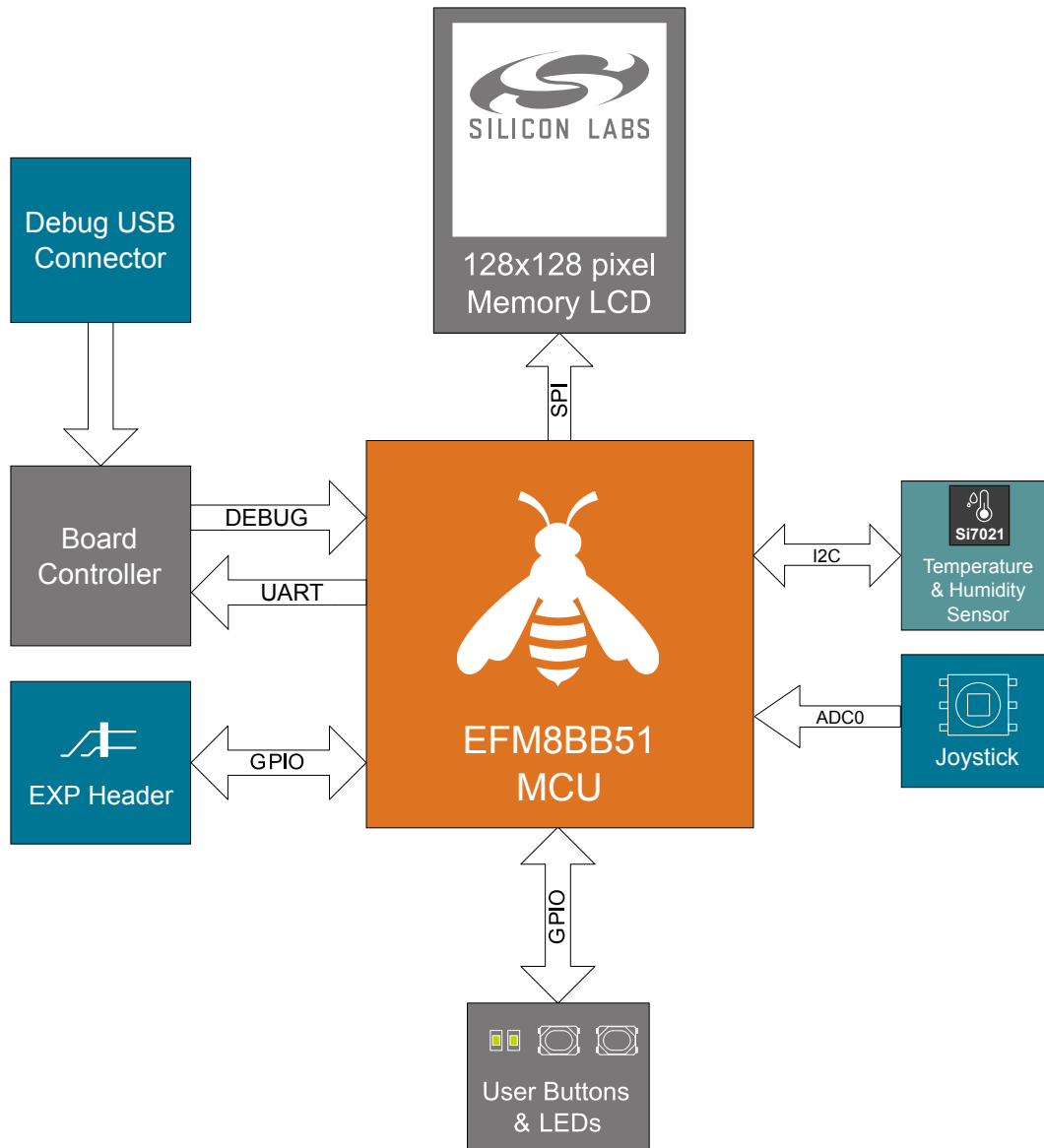

Figure 2.1. Kit Block Diagram

3. Kit Hardware Layout

The layout of the BB51 Pro Kit is shown below.

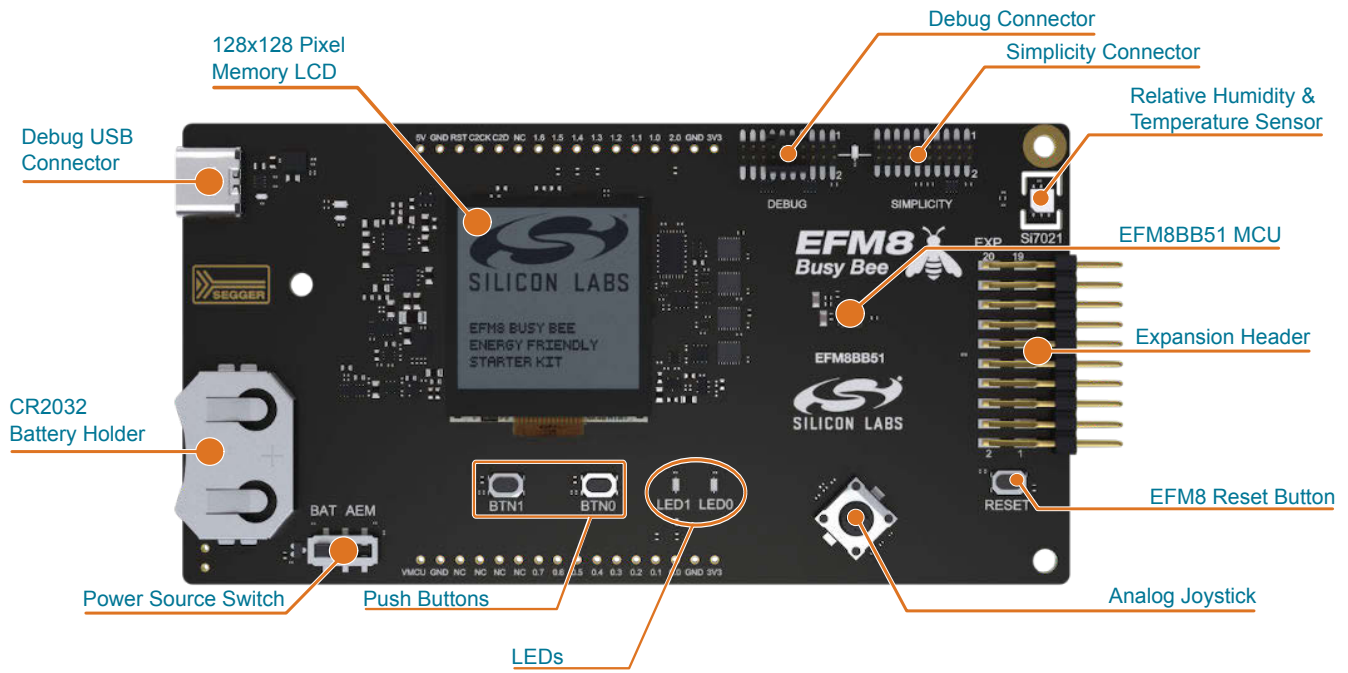

Figure 3.1. BB51 Pro Kit Hardware Layout

4. Connectors

4.1 Breakout Pads

Most of the EFM8BB51's GPIO pins are available on two pin header rows at the top and bottom edges of the board. These have a standard 2.54 mm pitch, and pin headers can be soldered in if required. In addition to the I/O pins, connections to power rails and ground are also provided. Note that some of the pins are used for kit peripherals or features and may not be available for a custom application without tradeoffs.

The figure below shows the pinout of the breakout pads and the pinout of the EXP header on the right edge of the board. The EXP header is further explained in the next section. The breakout pad connections are also printed in silkscreen next to each pin for easy reference.

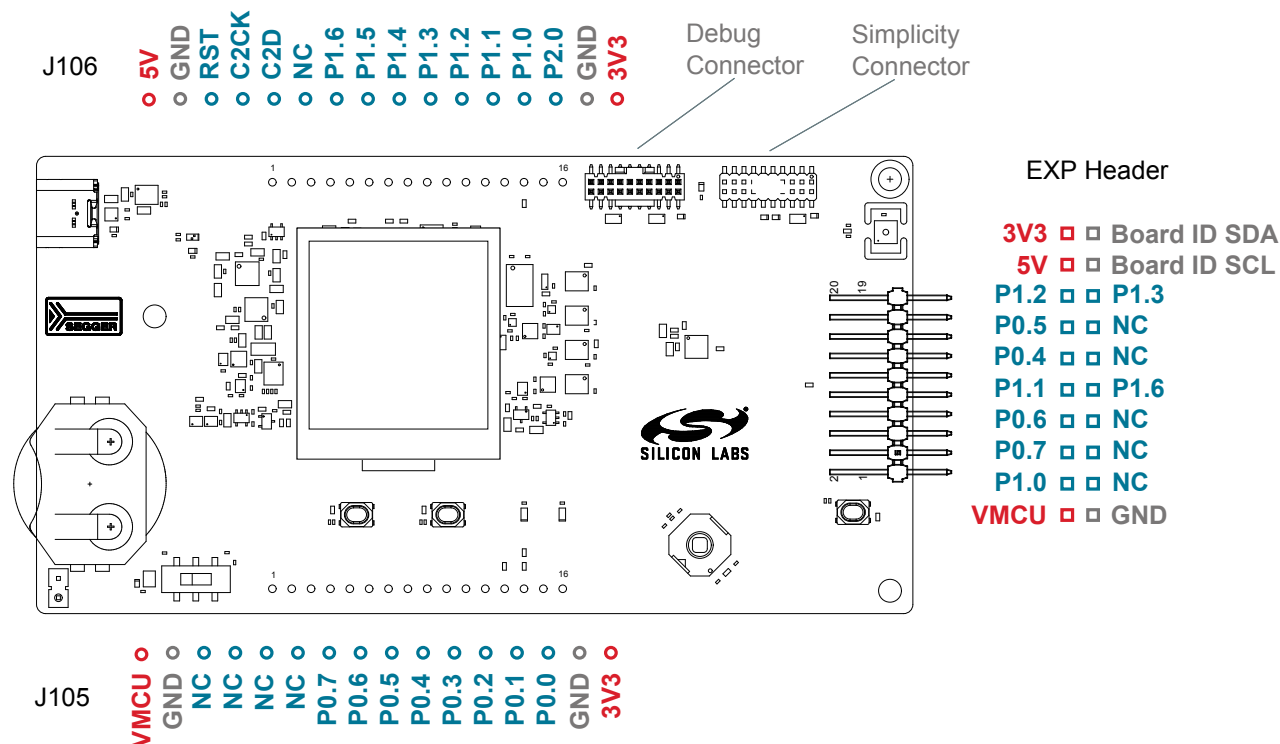

Figure 4.1. Breakout Pads and Expansion Header

The table below shows the pin connections of the breakout pads. It also shows which kit peripherals or features are connected to the different pins.

Table 4.1. Bottom Row (J105) Pinout

Pin	EFM8BB51 I/O pin	Shared Feature
1	VMCU	EFM8BB51 voltage domain (measured by AEM)
2	GND	Ground
3	NC	
4	NC	
5	NC	
6	NC	
7	P0.7	EXP6
8	P0.6	EXP8, MCU_DISP_SCLK
9	P0.5	EXP14, VCOM_RX

Pin	EFM8BB51 I/O pin	Shared Feature
10	P0.4	EXP12, VCOM_TX
11	P0.3	UIF_BUTTON1
12	P0.2	UIF_BUTTON0
13	P0.1	MCU_DISP_CS
14	P0.0	VCOM_ENABLE
15	GND	Ground
16	3V3	Board controller supply

Table 4.2. Top Row (J102) Pinout

Pin	EFM8BB51 I/O pin	Shared Feature
1	5V	Board USB voltage
2	GND	Ground
3	RST/C2CK	DEBUG_RESETN (DEBUG_C2CK Shared Pin)
4	C2CK/RST	DEBUG_C2CK (DEBUG_RESETN Shared Pin)
5	C2D/P2.0	DEBUG_C2D (DEBUG_C2DPS, MCU_DISP_ENABLE Shared Pin)
6	NC	
7	P1.6	EXP9, UIF_LED1
8	P1.5	UIF_LED0
9	P1.4	UIF_JOYSTICK
10	P1.3	EXP15, SENSOR_I2C_SCL
11	P1.2	EXP16, SENSOR_I2C_SDA
12	P1.1	EXP10
13	P1.0	EXP4, MCU_DISP_MOSI
14	P2.0/C2D	MCU_DISP_ENABLE (DEBUG_C2D, DEBUG_C2DPS Shared Pin)
15	GND	Ground
16	3V3	Board controller supply

4.2 EXP Header

On the right side of the board, an angled 20-pin EXP header is provided to allow connection of peripherals or plugin boards. The connector contains a number of I/O pins that can be used with most of the EFM8BB51 Busy Bee's features. Additionally, the VMCU, 3V3 and 5V power rails are also exposed.

The connector follows a standard which ensures that commonly used peripherals such as a SPI, a UART, and I²C bus are available on fixed locations on the connector. The rest of the pins are used for general purpose I/O. This allows the definition of expansion boards that can plug into a number of different Silicon Labs kits.

The figure below shows the pin assignment of the EXP header for the BB51 Pro Kit. Because of limitations in the number of available GPIO pins, some of the EXP header pins are shared with kit features.

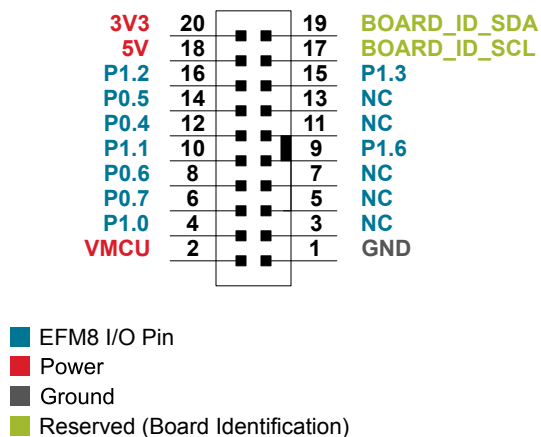

Figure 4.2. EXP Header

Table 4.3. EXP Header Pinout

Pin	Connection	EXP Header Function	Shared Feature	Peripheral Mapping
20	3V3	Board controller supply		
18	5V	Board controller USB voltage		
16	P1.2	I2C_SDA	SENSOR_I2C_SDA	SMB0_SDA
14	P0.5	UART_RX	VCOM_RX	UART0_RX
12	P0.4	UART_TX	VCOM_TX	UART0_TX
10	P1.1	SPI_CS		SPI0_CS
8	P0.6	SPI_SCK	MCU_DISP_SCLK	SPI0_SCK
6	P0.7	SPI_MISO		SPI0_MISO
4	P1.0	SPI_MOSI	MCU_DISP_MOSI	SPI0_MOSI
2	VMCU	EFM8BB51 voltage domain, included in AEM measurements.		
19	BOARD_ID_SDA	Connected to Board Controller for identification of add-on boards.		
17	BOARD_ID_SCL	Connected to Board Controller for identification of add-on boards.		
15	P1.3	I2C_SCL	SENSOR_I2C_SCL	SMB0_SCL
13	NC	GPIO		
11	NC	GPIO		
9	P1.6	GPIO	UIF_LED1	

Pin	Connection	EXP Header Function	Shared Feature	Peripheral Mapping
7	NC	GPIO		
5	NC	GPIO		
3	NC	GPIO		
1	GND	Ground		

4.3 Debug Connector (DBG)

The debug connector serves a dual purpose, based on the debug mode, which can be set up using Simplicity Studio. If the "Debug IN" mode is selected, the connector allows an external debugger to be used with the on-board EFM8BB51. If the "Debug OUT" mode is selected, the connector allows the kit to be used as a debugger towards an external target. If the "Debug MCU" mode (default) is selected, the connector is isolated from the debug interface of both the board controller and the on-board target device.

Because this connector is automatically switched to support the different operating modes, it is only available when the board controller is powered (J-Link USB cable connected). If debug access to the target device is required when the board controller is unpowered, this should be done by connecting directly to the appropriate pins on the breakout header.

The pinout of the connector follows that of the standard ARM Cortex Debug 19-pin connector. The pinout is described in detail below. Note that even though the connector supports JTAG in addition to Serial Wire Debug, it does not necessarily mean that the kit or the on-board target device supports this.

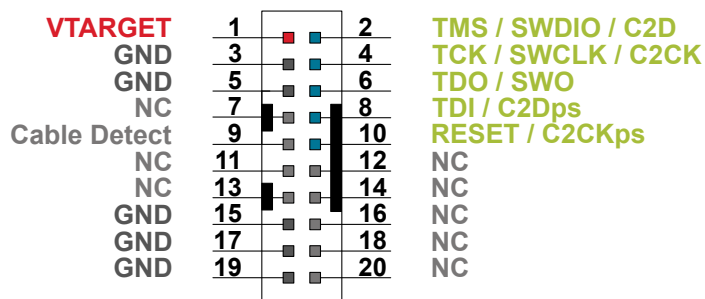

Figure 4.3. Debug Connector

Even though the pinout matches the pinout of an ARM Cortex Debug connector, these are not fully compatible as pin 7 is physically removed from the Cortex Debug connector. Some cables have a small plug that prevents them from being used when this pin is present. If this is the case, remove the plug, or use a standard 2x10 1.27 mm straight cable instead.

Table 4.4. Debug Connector Pin Descriptions

Pin Number(s)	Function	Note
1	VTARGET	Target reference voltage. Used for shifting logical signal levels between target and debugger.
2	TMS / SDWIO / C2D	JTAG test mode select, Serial Wire data or C2 data
4	TCK / SWCLK / C2CK	JTAG test clock, Serial Wire clock or C2 clock
6	TDO/SWO	JTAG test data out or Serial Wire output
8	TDI / C2Dps	JTAG test data in, or C2D "pin sharing" function
10	RESET / C2CKps	Target device reset, or C2CK "pin sharing" function
12	NC	TRACECLK
14	NC	TRACED0
16	NC	TRACED1
18	NC	TRACED2
20	NC	TRACED3
9	Cable detect	Connect to ground
11, 13	NC	Not connected
3, 5, 15, 17, 19	GND	

4.4 Simplicity Connector

The Simplicity Connector featured on the pro kit enables advanced debugging features such as the AEM and the Virtual COM port to be used towards an external target. The pinout is illustrated in the figure below.

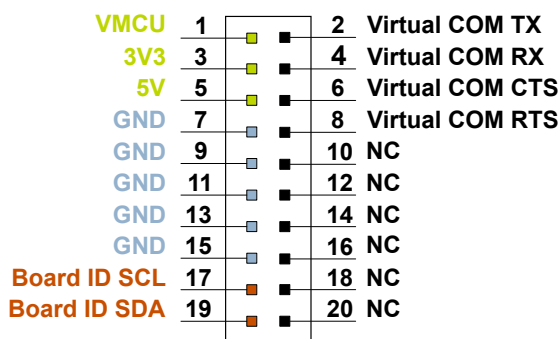

Figure 4.4. Simplicity Connector

The signal names in the figure and the pin description table are referenced from the board controller. This means that VCOM_TX should be connected to the RX pin on the external target, VCOM_RX to the target's TX pin, VCOM_CTS to the target's RTS pin, and VCOM_RTS to the target's CTS pin.

Note: Current drawn from the VMCU voltage pin is included in the AEM measurements, while the 3V3 and 5V voltage pins are not. To monitor the current consumption of an external target with the AEM, put the on-board MCU in its lowest energy mode to minimize its impact on the measurements.

Table 4.5. Simplicity Connector Pin Descriptions

Pin Number(s)	Function	Description
1	VMCU	3.3 V power rail, monitored by the AEM
3	3V3	3.3 V power rail
5	5V	5 V power rail
2	VCOM_TX	Virtual COM TX
4	VCOM_RX	Virtual COM RX
6	VCOM_CTS	Virtual COM CTS
8	VCOM_RTS	Virtual COM RTS
17	EXT_ID_SCL	Board ID SCL
19	EXT_ID_SDA	Board ID SDA
10, 12, 14, 16, 18, 20	NC	Not connected
7, 9, 11, 13, 15	GND	Ground

5. Power Supply and Reset

5.1 MCU Power Selection

The EFM8BB51 on the pro kit can be powered by one of these sources:

- The debug USB cable
- 3 V coin cell battery

The power source for the MCU is selected with the slide switch in the lower left corner of the pro kit. The figure below shows how the different power sources can be selected with the slide switch.

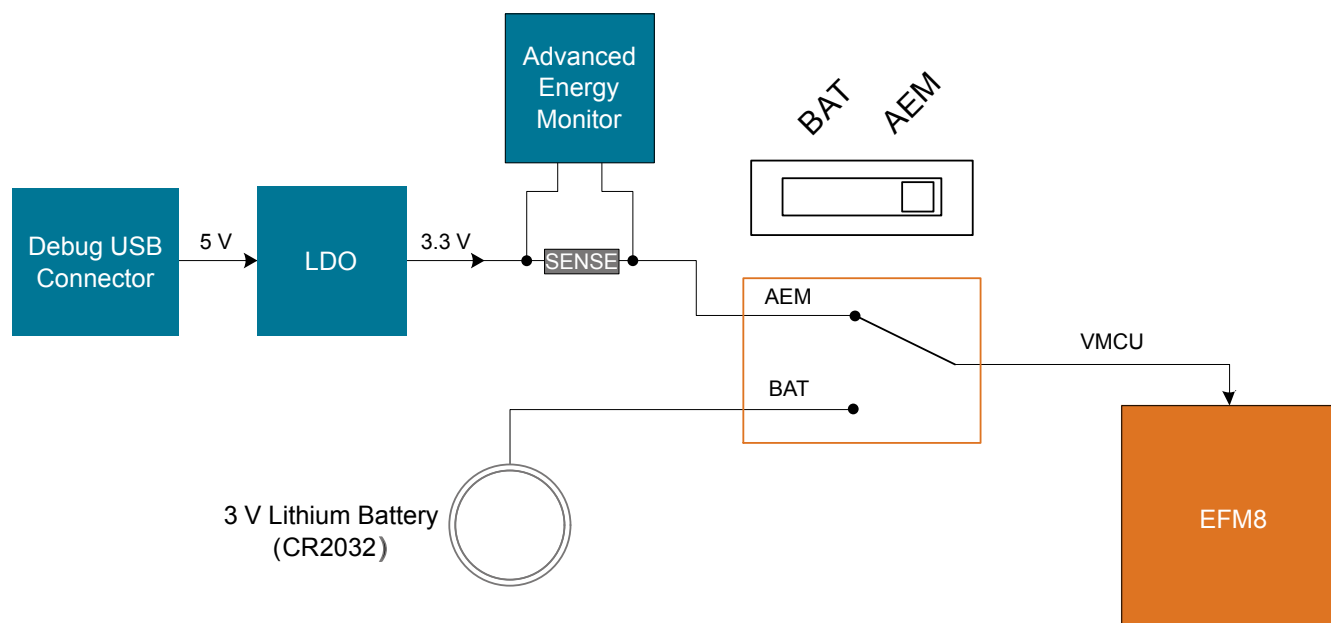

Figure 5.1. Power Switch

With the switch in the **AEM** position, a low noise 3.3 V LDO on the pro kit is used to power the EFM8BB51. This LDO is again powered from the debug USB cable. The Advanced Energy Monitor is now connected in series, allowing accurate high-speed current measurements and energy debugging/profiling.

With the switch in the **BAT** position, a 20 mm coin cell battery in the CR2032 socket can be used to power the device. With the switch in this position, no current measurements are active. This is the recommended switch position when powering the MCU with an external power source.

Note: The Advanced Energy Monitor can only measure the current consumption of the EFM8BB51 when the power selection switch is in the **AEM** position.

5.2 Board Controller Power

The board controller is responsible for important features, such as the debugger and the AEM, and is powered exclusively through the USB port in the top left corner of the board. This part of the kit resides on a separate power domain, so a different power source can be selected for the target device while retaining debugging functionality. This power domain is also isolated to prevent current leakage from the target power domain when power to the board controller is removed.

The board controller power domain is not influenced by the position of the power switch.

The kit has been carefully designed to keep the board controller and the target power domains isolated from each other as one of them powers down. This ensures that the target EFM8BB51 device will continue to operate in the **BAT** mode.

5.3 EFM8BB51 Reset

The EFM8BB51 MCU can be reset by a few different sources:

- A user pressing the RESET button
- The on-board debugger pulling the #RESET pin low
- An external debugger pulling the #RESET pin low

In addition to the reset sources mentioned above, a reset to the EFM8BB51 will also be issued during board controller boot-up. This means that removing power to the board controller (unplugging the J-Link USB cable) will not generate a reset, but plugging the cable back in will, as the board controller boots up.

6. Peripherals

The pro kit has a set of peripherals that showcase some of the features of the EFM8BB51.

Note that most EFM8BB51 I/O routed to peripherals are also routed to the breakout pads or the EXP header, which must be taken into consideration when using these.

6.1 Push Buttons and LEDs

The kit has two user push buttons marked BTN0 and BTN1. They are connected directly to the EFM8BB51 and are debounced by RC filters with a time constant of 1 ms. The buttons are connected to pins P0.2 and P0.3.

The kit also features two yellow LEDs marked LED0 and LED1 that are controlled by GPIO pins on the EFM8BB51. The LEDs are connected to pins P1.5 and P1.6 in an active-high configuration.

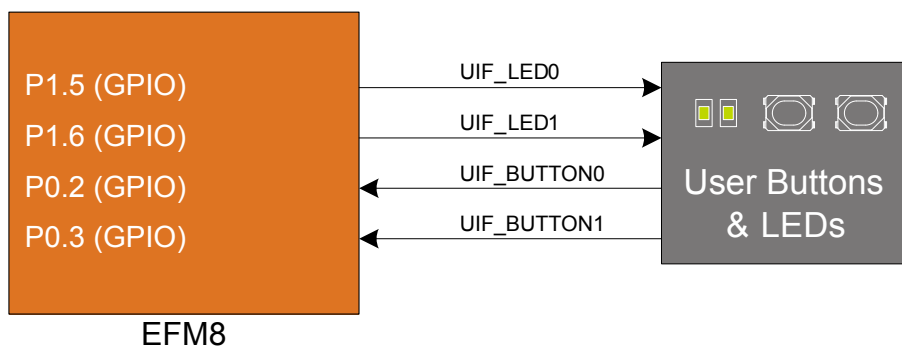

Figure 6.1. Buttons and LEDs

6.2 Joystick

The kit has an analog joystick with 8 measurable positions. This joystick is connected to the EFM8 on the P1.4 pin and uses different resistor values to create voltages measurable by the ADC0.

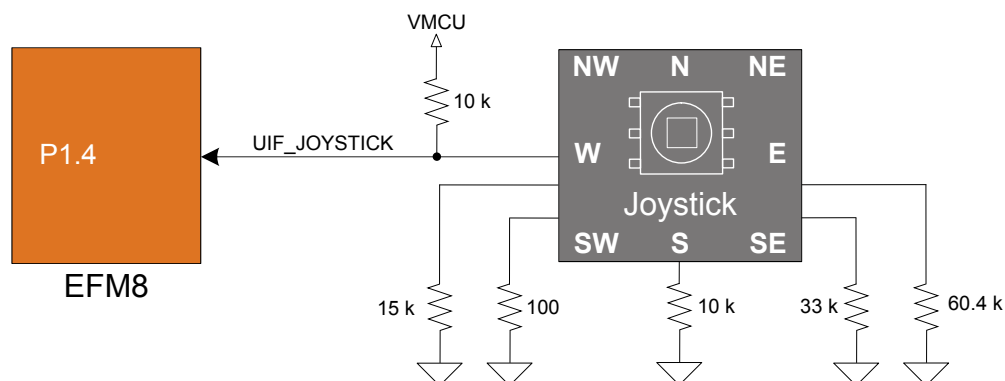

Figure 6.2. Joystick

Table 6.1. Joystick Resistor Combinations

Direction	Resistors Combinations (kΩ)	Expected UIF_JOYSTICK Voltage (V) ¹
Center press	$\frac{0.1}{0.1 + 10}$	0.033
Up (N)	$\frac{60.4}{60.4 + 10}$	2.831
Up-Right (NE)	$\frac{(N \parallel E)}{(N \parallel E) + 10} = \frac{21.34}{21.34 + 10}$	2.247
Right (E)	$\frac{33}{33 + 10}$	2.533
Down-Right (SE)	$\frac{(S \parallel E)}{(S \parallel E) + 10} = \frac{7.67}{7.67 + 10}$	1.433
Down (S)	$\frac{10}{10 + 10}$	1.650
Down-Left (SW)	$\frac{(S \parallel W)}{(S \parallel W) + 10} = \frac{6}{6 + 10}$	1.238
Left (W)	$\frac{15}{15 + 10}$	1.980
Up-Left (NW)	$\frac{(N \parallel W)}{(N \parallel W) + 10} = \frac{12.01}{12.01 + 10}$	1.801

Note:
 1. These calculated values assume a VMCU of 3.3 V.

6.3 Memory LCD-TFT Display

A 1.28-inch SHARP Memory LCD-TFT is available on the kit to enable interactive applications to be developed. The display has a high resolution of 128 x 128 pixels and consumes very little power. It is a reflective monochrome display, so each pixel can only be light or dark, and no backlight is needed in normal daylight conditions. Data sent to the display is stored in the pixels on the glass, which means no continuous refreshing is required to maintain a static image.

The display interface consists of a SPI-compatible serial interface and some extra control signals. Pixels are not individually addressable, instead data is sent to the display one line (128 bits) at a time.

The Memory LCD-TFT display is shared with the kit's board controller, allowing the board controller application to display useful information when the user application is not using the display. The user application always controls ownership of the display with the DISP_ENABLE signal:

- DISP_ENABLE = LOW: The board controller has control of the display
- DISP_ENABLE = HIGH: The user application (EFM8BB51) has control of the display

Power to the display is sourced from the target application power domain when the EFM8BB51 controls the display and from the board controller's power domain when the DISP_ENABLE line is low. Data is clocked in on DISP_SI when DISP_CS is high, and the clock is sent on DISP_SCLK. The maximum supported clock speed is 1.1 MHz.

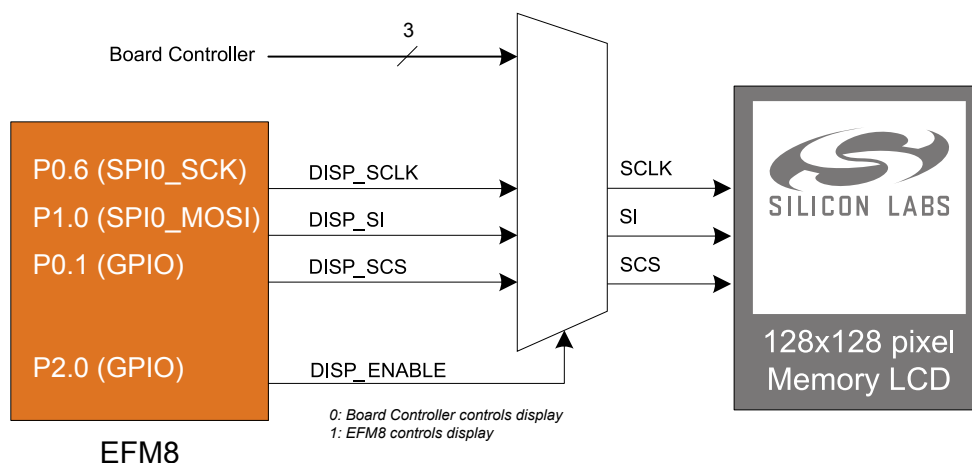

Figure 6.3. 128x128 Pixel Memory LCD

6.4 Si7021 Relative Humidity and Temperature Sensor

The Si7021 I²C relative humidity and temperature sensor is a monolithic CMOS IC integrating humidity and temperature sensor elements, an analog-to-digital converter, signal processing, calibration data, and an I²C Interface. The patented use of industry-standard, low-K polymeric dielectrics for sensing humidity enables the construction of low-power, monolithic CMOS Sensor ICs with low drift and hysteresis, and excellent long term stability.

The humidity and temperature sensors are factory-calibrated and the calibration data is stored in the on-chip non-volatile memory. This ensures that the sensors are fully interchangeable, with no recalibration or software changes required.

The Si7021 is available in a 3x3 mm DFN package and is reflow solderable. It can be used as a hardware and software-compatible drop-in upgrade for existing RH/temperature sensors in 3x3 mm DFN-6 packages, featuring precision sensing over a wider range and lower power consumption. The optional factory-installed cover offers a low profile, convenient means of protecting the sensor during assembly (e.g., reflow soldering) and throughout the life of the product, excluding liquids (hydrophobic/oleophobic) and particulates.

The Si7021 offers an accurate, low-power, factory-calibrated digital solution ideal for measuring humidity, dew-point, and temperature in applications ranging from HVAC/R and asset tracking to industrial and consumer platforms.

The I²C bus used for the Si7021 is shared with the EXP header. The sensor is powered by VMCU, which means the sensor's current consumption is included in the AEM measurements.

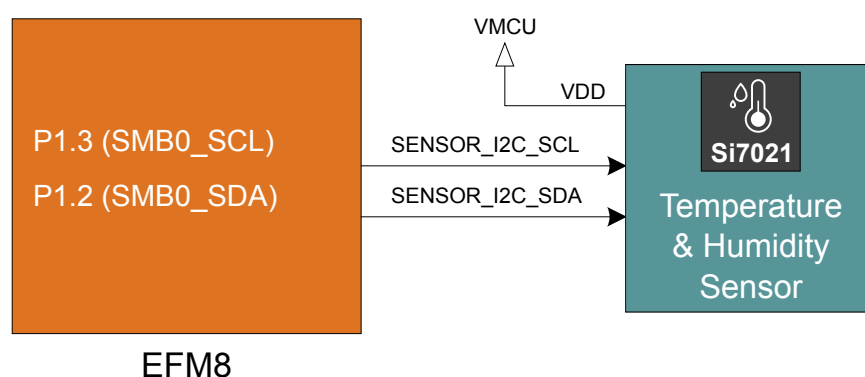

Figure 6.4. Si7021 Relative Humidity and Temperature Sensor

Refer to the Silicon Labs web pages for more information: <http://www.silabs.com/humidity-sensors>.

6.5 Virtual COM Port

An asynchronous serial connection to the board controller is provided for application data transfer between a host PC and the target EFM8BB51, which eliminates the need for an external serial port adapter.

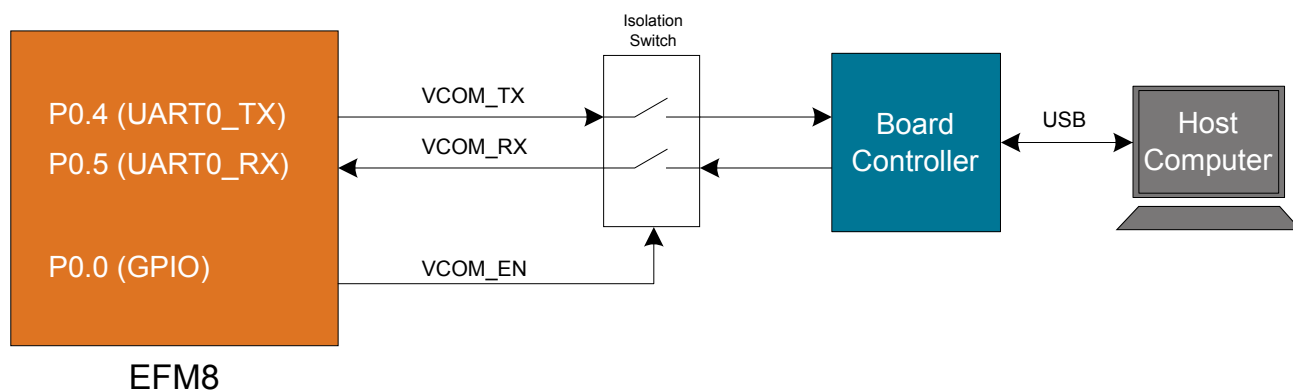

Figure 6.5. Virtual COM Port Interface

The Virtual COM port consists of a physical UART between the target device and the board controller, and a logical function in the board controller that makes the serial port available to the host PC over USB. The UART interface consists of two pins and an enable signal.

Table 6.2. Virtual COM Port Interface Pins

Signal	Description
VCOM_TX	Transmit data from the EFM8BB51 to the board controller
VCOM_RX	Receive data from the board controller to the EFM8BB51
VCOM_ENABLE	Enables the VCOM interface, allowing data to pass through to the board controller

Note: The VCOM port is only available when the board controller is powered, which requires the J-Link USB cable to be inserted.

7. Advanced Energy Monitor

7.1 Usage

The Advanced Energy Monitor (AEM) data is collected by the board controller and can be displayed by the Energy Profiler, available through Simplicity Studio. By using the Energy Profiler, current consumption and voltage can be measured and linked to the actual code running on the EFM8BB51 in realtime.

7.2 Theory of Operation

To accurately measure current ranging from $0.1\ \mu\text{A}$ to $47\ \text{mA}$ (114 dB dynamic range), a current sense amplifier is utilized together with a dual gain stage. The current sense amplifier measures the voltage drop over a small series resistor. The gain stage further amplifies this voltage with two different gain settings to obtain two current ranges. The transition between these two ranges occurs around $250\ \mu\text{A}$. Digital filtering and averaging is done within the board controller before the samples are exported to the Energy Profiler application.

During kit startup, an automatic calibration of the AEM is performed, which compensates for the offset error in the sense amplifiers.

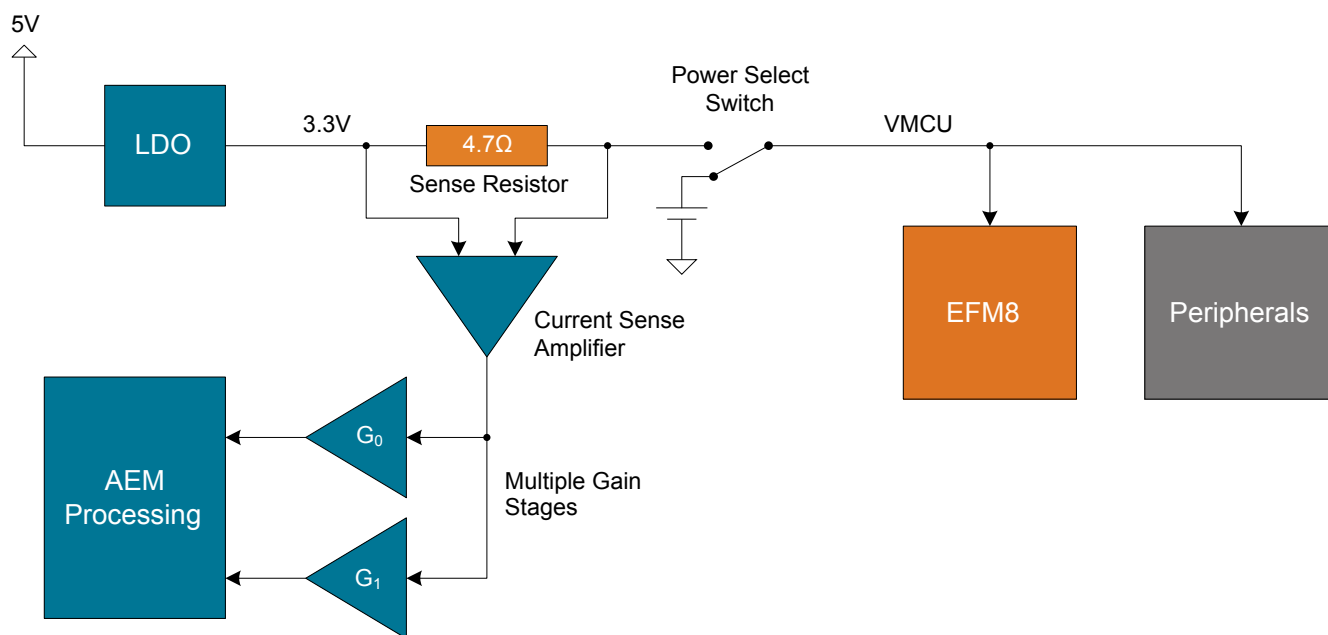

Figure 7.1. Advanced Energy Monitor

7.3 Accuracy and Performance

The AEM is capable of measuring currents in the range of $0.1\ \mu\text{A}$ to $47\ \text{mA}$. For currents above $250\ \mu\text{A}$, the AEM is accurate within $0.1\ \text{mA}$. When measuring currents below $250\ \mu\text{A}$, the accuracy increases to $1\ \mu\text{A}$. Although the absolute accuracy is $1\ \mu\text{A}$ in the sub $250\ \mu\text{A}$ range, the AEM is able to detect changes in the current consumption as small as $100\ \text{nA}$. The AEM produces 6250 current samples per second.

8. On-Board Debugger

The BB51 Pro Kit contains an integrated debugger, which can be used to download code and debug the EFM8BB51. In addition to programming the EFM8BB51 on the kit, the debugger can also be used to program and debug external Silicon Labs EFM32, EFM8, EZR32, and EFR32 devices.

The debugger supports three different debug interfaces used with Silicon Labs devices:

- Serial Wire Debug, which is used with all EFM32, EFR32, and EZR32 devices
- JTAG, which can be used with EFR32 and some EFM32 devices
- C2 Debug, which is used with EFM8 devices

To ensure accurate debugging, use the appropriate debug interface for your device. The debug connector on the board supports all three of these modes.

8.1 Debug Modes

To program external devices, use the debug connector to connect to a target board and set the debug mode to **[Out]**. The same connector can also be used to connect an external debugger to the EFM8BB51 MCU on the kit by setting debug mode to **[In]**.

Selecting the active debug mode is done in Simplicity Studio.

Debug MCU: In this mode, the on-board debugger is connected to the EFM8BB51 on the kit.

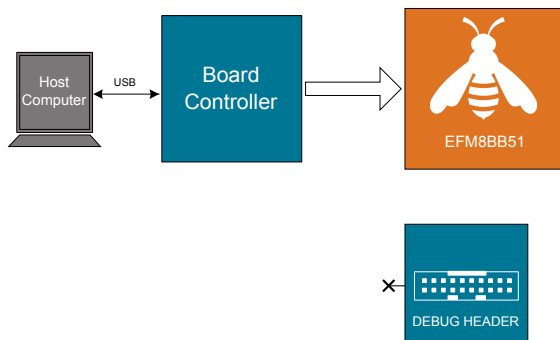

Figure 8.1. Debug MCU

Debug OUT: In this mode, the on-board debugger can be used to debug a supported Silicon Labs device mounted on a custom board.

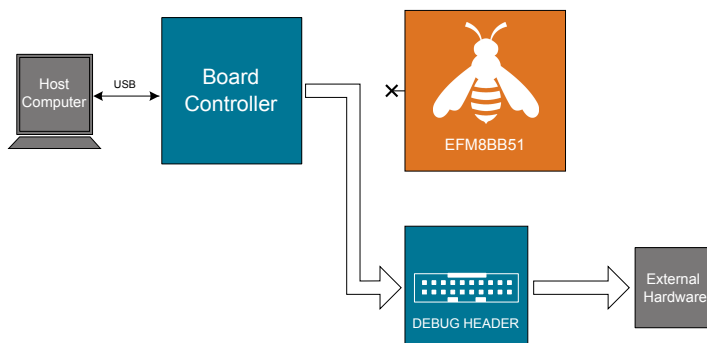

Figure 8.2. Debug OUT

Debug IN: In this mode, the on-board debugger is disconnected, and an external debugger can be connected to debug the EFM8BB51 on the kit.

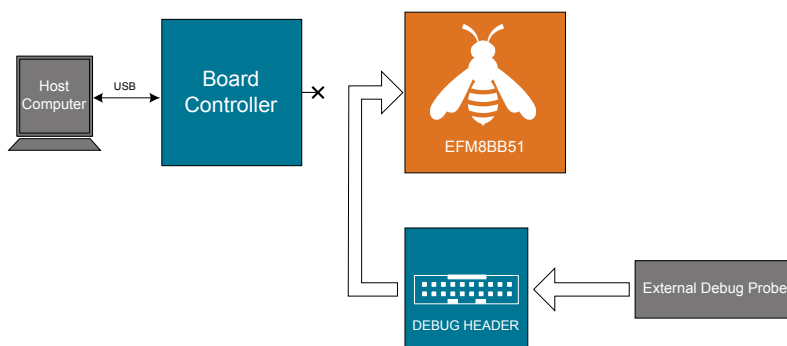

Figure 8.3. Debug IN

Note: For "Debug IN" to work, the kit board controller must be powered through the Debug USB connector.

8.2 Debugging During Battery Operation

When the EFM8BB51 is battery-powered and the J-Link USB is still connected, the on-board debug functionality is available. If the USB power is disconnected, the Debug IN mode will stop working.

If debug access is required when the target is running off another energy source, such as a battery, and the board controller is powered down, make direct connections to the GPIO used for debugging. This can be done by connecting to the appropriate pins of the breakout pads. Some Silicon Labs kits provide a dedicated pin header for this purpose.

9. Kit Configuration and Upgrades

The kit configuration dialog in Simplicity Studio allows you to change the J-Link adapter debug mode, upgrade its firmware, and change other configuration settings. To download Simplicity Studio, go to silabs.com/simplicity.

In the main window of the Simplicity Studio's Launcher perspective, the debug mode and firmware version of the selected J-Link adapter are shown. Click the **[Change]** link next to any of them to open the kit configuration dialog.

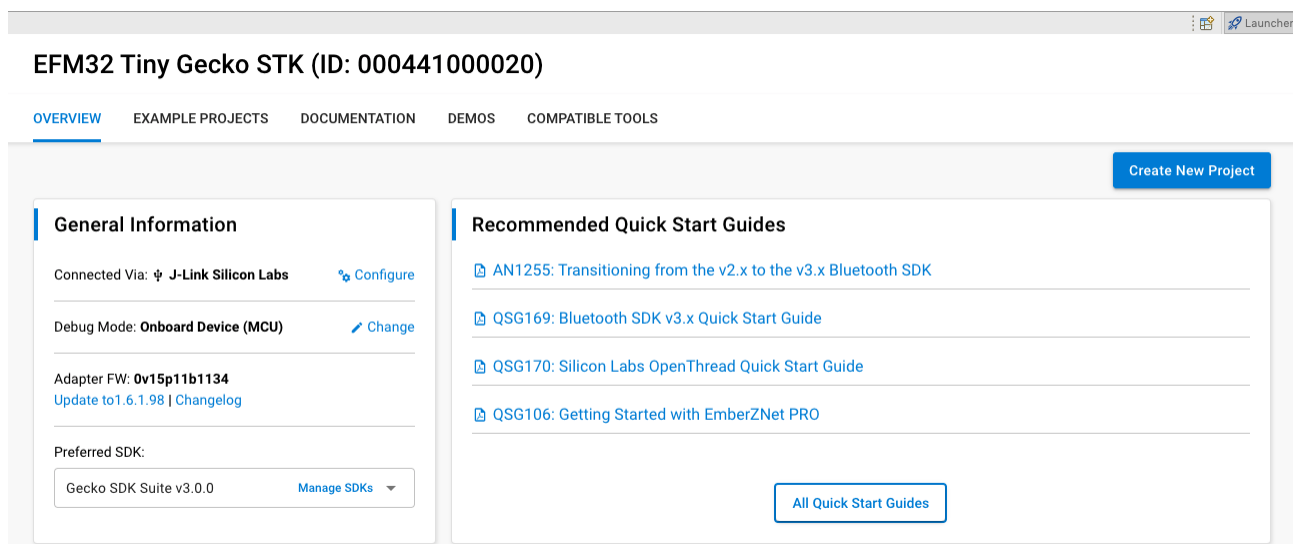

Figure 9.1. Simplicity Studio Kit Information

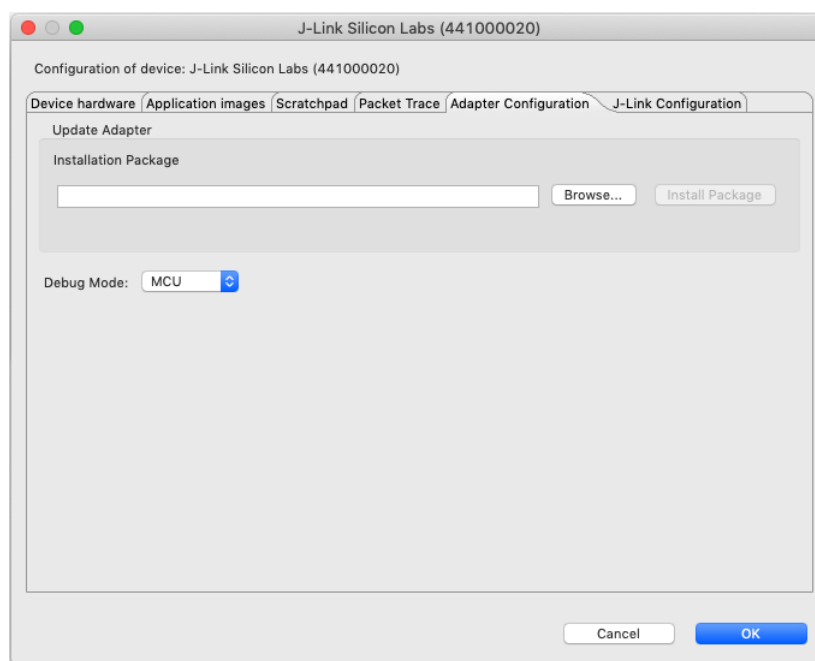

Figure 9.2. Kit Configuration Dialog

9.1 Firmware Upgrades

Upgrading the kit firmware is done through Simplicity Studio. Simplicity Studio will automatically check for new updates on startup.

You can also use the kit configuration dialog for manual upgrades. Click the **[Browse]** button in the **[Update Adapter]** section to select the correct file ending in `.emz`. Then, click the **[Install Package]** button.

10. Schematics, Assembly Drawings, and BOM

Schematics, assembly drawings, and bill of materials (BOM) are available through Simplicity Studio when the kit documentation package has been installed. They are also available from the kit page on the Silicon Labs website: <http://www.silabs.com/>.

11. Kit Revision History and Errata

11.1 Revision History

The kit revision can be found printed on the box label of the kit, as outlined in the figure below.

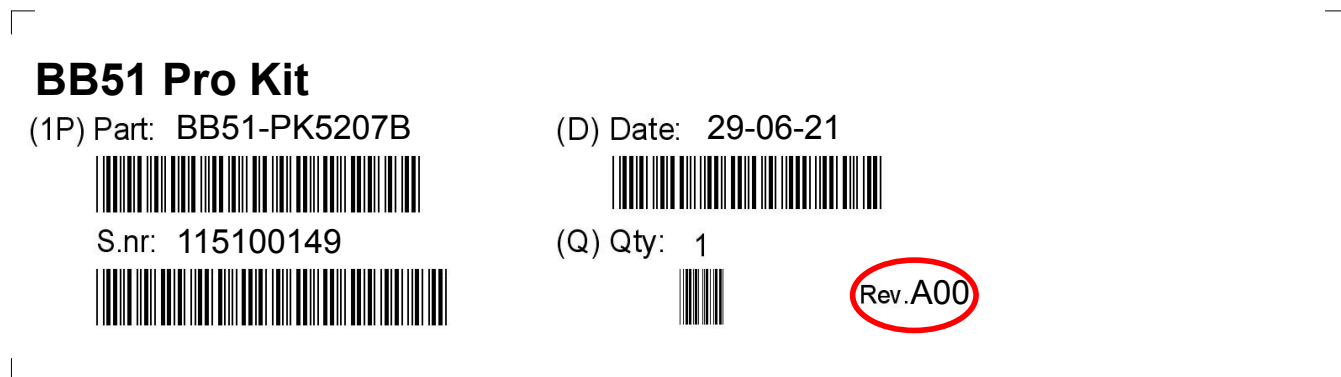

Figure 11.1. Revision Information

Table 11.1. BB51-PK5207B Kit Revision History

Kit Revision	Released	Description
A00	29 June 2021	Initial kit revision based on BB51-PK5207A where BRD5207A Rev. A02 has been replaced with BRD5207B Rev. A01.

Table 11.2. BB51-PK5207A Kit Revision History

Kit Revision	Released	Description
A02	17 March 2021	Kit revised due to BRD5207A being updated to revision A02.
A01	4 November 2020	Initial kit revision.

11.2 Errata

There are no known errata at present.

12. Document Revision History

Revision 1.2

October 2021

Changed document title.

Revision 1.1

September 2021

Updated kit from BB51-PK5207A to BB51-PK5207B.

Revision 1.0

December 2020

Initial document version.

Simplicity Studio

One-click access to MCU and wireless tools, documentation, software, source code libraries & more. Available for Windows, Mac and Linux!



IoT Portfolio
www.silabs.com/IoT



SW/HW
www.silabs.com/simplicity



Quality
www.silabs.com/quality



Support & Community
www.silabs.com/community

Disclaimer

Silicon Labs intends to provide customers with the latest, accurate, and in-depth documentation of all peripherals and modules available for system and software implementers using or intending to use the Silicon Labs products. Characterization data, available modules and peripherals, memory sizes and memory addresses refer to each specific device, and "Typical" parameters provided can and do vary in different applications. Application examples described herein are for illustrative purposes only. Silicon Labs reserves the right to make changes without further notice to the product information, specifications, and descriptions herein, and does not give warranties as to the accuracy or completeness of the included information. Without prior notification, Silicon Labs may update product firmware during the manufacturing process for security or reliability reasons. Such changes will not alter the specifications or the performance of the product. Silicon Labs shall have no liability for the consequences of use of the information supplied in this document. This document does not imply or expressly grant any license to design or fabricate any integrated circuits. The products are not designed or authorized to be used within any FDA Class III devices, applications for which FDA premarket approval is required or Life Support Systems without the specific written consent of Silicon Labs. A "Life Support System" is any product or system intended to support or sustain life and/or health, which, if it fails, can be reasonably expected to result in significant personal injury or death. Silicon Labs products are not designed or authorized for military applications. Silicon Labs products shall under no circumstances be used in weapons of mass destruction including (but not limited to) nuclear, biological or chemical weapons, or missiles capable of delivering such weapons. Silicon Labs disclaims all express and implied warranties and shall not be responsible or liable for any injuries or damages related to use of a Silicon Labs product in such unauthorized applications.

Note: This content may contain offensive terminology that is now obsolete. Silicon Labs is replacing these terms with inclusive language wherever possible. For more information, visit www.silabs.com/about-us/inclusive-lexicon-project

Trademark Information

Silicon Laboratories Inc.[®], Silicon Laboratories[®], Silicon Labs[®], SiLabs[®] and the Silicon Labs logo[®], Bluegiga[®], Bluegiga Logo[®], EFM[®], EFM32[®], EFR, Ember[®], Energy Micro, Energy Micro logo and combinations thereof, "the world's most energy friendly microcontrollers", Redpine Signals[®], WiSeConnect, n-Link, ThreadArch[®], EZLink[®], EZRadio[®], EZRadioPRO[®], Gecko[®], Gecko OS, Gecko OS Studio, Precision32[®], Simplicity Studio[®], Telegesis, the Telegesis Logo[®], USBXpress[®], Zentri, the Zentri logo and Zentri DMS, Z-Wave[®], and others are trademarks or registered trademarks of Silicon Labs. ARM, CORTEX, Cortex-M3 and THUMB are trademarks or registered trademarks of ARM Holdings. Keil is a registered trademark of ARM Limited. Wi-Fi is a registered trademark of the Wi-Fi Alliance. All other products or brand names mentioned herein are trademarks of their respective holders.



Silicon Laboratories Inc.
400 West Cesar Chavez
Austin, TX 78701
USA

www.silabs.com