

Positioning Sensors • self-aligning, pneumatic

22800.0320



Product Description

Used in jigs and fixtures as positioning control for unmachined workpieces (version flat-faced ball, bearing surface ribbed) or pre-machined workpieces (flat-faced ball, bearing surface plain). The response accuracy for the flat-faced ball version with plain bearing surface is in the range of 0.015-0.075 mm depending on the workpiece and for the flat-faced ball version with ribbed bearing surface constant at 0.005 mm. The system is monitored by the compressed-air backwash which indicated on the monitoring unit (Art. No. 22800.0701).

Material

Ball

- Ball-bearing steel, hardened

Body

- Heat-treated steel, tempered, phosphated

More information

Notes

Further information on request.

Further products

- Monitoring Units, for positioning sensors, pneumatic

Drawing

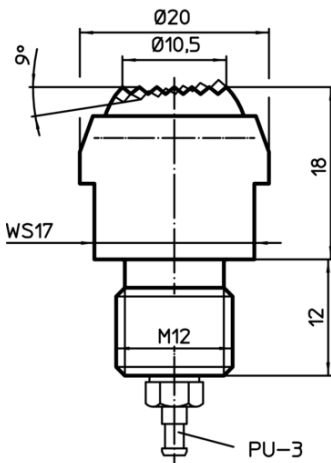

picture 1

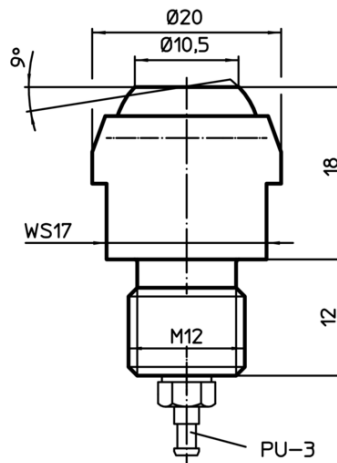

picture 2

Order information

Load capacity for static load max. [kN]	[g]	Art. No.
		flat-faced ball, bearing surface plain
15	49	

Application example

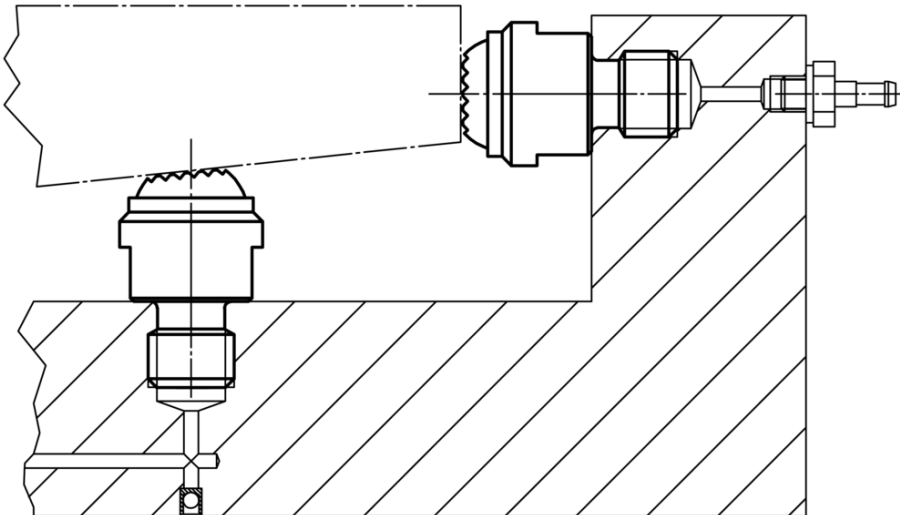

Compliance

RoHS compliant

Compliant according to Directive 2011/65/EU and Directive 2015/863

Does not contain SVHC substances

No SVHC substances with more than 0.1% w/w contained - SVHC list [REACH] as of 10.06.2022

Does not contain Proposition 65 substances

No Proposition 65 substances included
<https://www.P65Warnings.ca.gov/>

Free from Conflict Minerals

This product does not contain any substances designated as "conflict minerals" such as tantalum, tin, gold or tungsten from the Democratic Republic of Congo or adjacent countries.