

Data sheet

Article Description

Article picture

Line-end Switch Type 8016

10 A, 250 V, 1-pole, on-off-switch, screwed housing and strain relief, screw terminals

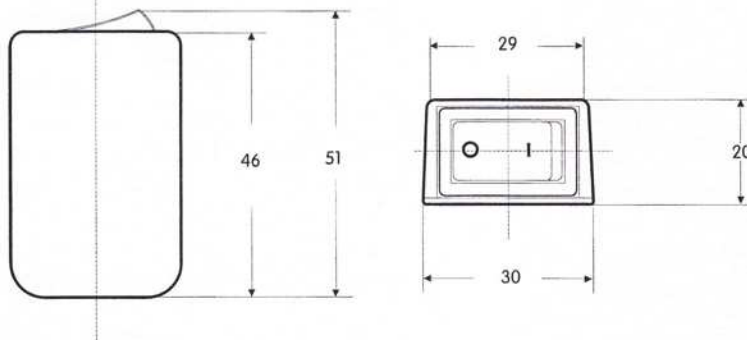

<i>inter BÄR-item</i>	<i>colour housing</i>	<i>rocker</i>
8016-001.01	white	white
8016-002.01	black	black

Technische Änderungen vorbehalten!

Der Anschluss an das 230 V-Netz darf nur von einer Elektro-Fachkraft durchgeführt werden!