

## Face milling cutters, 45°

For milling cutter indexable inserts SEET 1204, SEEW 1204

**ATORN®**

### Application

Universal use in all materials.

### Version

- Wear-resistant, nickel-plated version
- With robust support design
- Extremely soft cut
- Variable pitch for smooth running
- Clamping screw tightening torque (indexable insert) M5 = 8 Nm

<b>Art. No.</b>	<b>16024 101</b>
<b>Min. cutting edge diameter</b>	100 mm
<b>Max. cutting edge diameter</b>	113 mm
<b>Length</b>	50 mm
<b>Bore diameter</b>	32 mm
<b>max. ap</b>	6 mm
<b>Number of cutting edges</b>	8 PCS

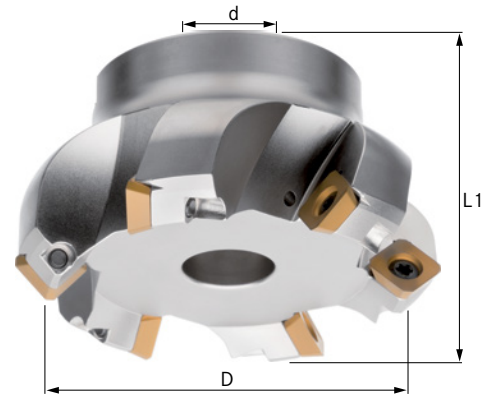

### EAN-Code

4050293320787

