

## Flanschlager DIN 502 Form A, mit Rotgussbuchse Rg7

**Werkstoff:** Grauguss GG25 (GJL-250).  
**Buchse:** Rg7 (CuSn7Zn4Pb7-C).  
**Bohrungstoleranz:** ISO D10.

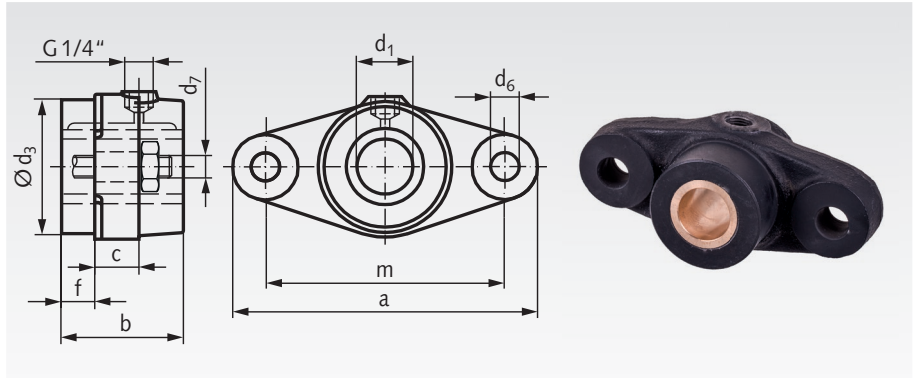

Bestellangaben: z.B.: Art.-Nr. 62102500,  
 Flanschlager DIN 502 A, 25 mm Bohrung

Artikel-Nr.	d <sub>1</sub> mm	a mm	b mm	c mm	d <sub>3</sub> <sup>h9</sup> mm	d <sub>6</sub> mm	d <sub>7</sub> mm	f mm	m mm	Gewicht kg
621 025 00	25	155	60	20	65	14	M12	20	120	1,4
621 030 00	30	155	60	20	65	14	M12	20	120	1,4
621 040 00	40	180	70	25	80	18	M16	20	140	3,0
621 050 00	50	210	80	30	90	22	M20	20	160	4,2

## Flanschlager DIN 502 Form B, ohne Buchse

**Werkstoff:** Grauguss GG25 (GJL-250).  
**Bohrungstoleranz:** ISO D7.

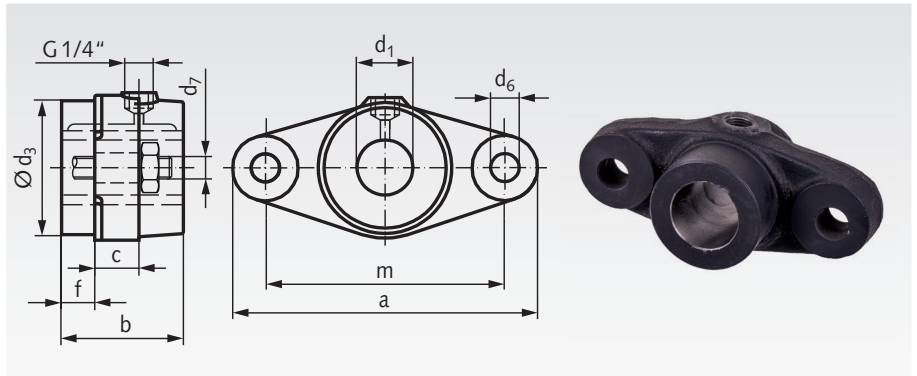

Bestellangaben: z.B.: Art.-Nr. 62112500,  
 Flanschlager DIN 502 B, 25 mm Bohrung

Artikel-Nr.	d <sub>1</sub> mm	a mm	b mm	c mm	d <sub>3</sub> <sup>h9</sup> mm	d <sub>6</sub> mm	d <sub>7</sub> mm	f mm	m mm	Gewicht kg
621 125 00	25	135	60	20	50	14	M12	20	100	1,2
621 130 00	30	135	60	20	50	14	M12	20	100	1,2
621 135 00	35	155	60	20	65	14	M12	20	120	1,4
621 140 00	40	155	60	20	65	14	M12	20	120	1,4

## Flanschlager DIN 503 Form A, mit Rotgussbuchse

**Werkstoff:** Grauguss GG25 (GJL-250).  
**Buchse:** Rg7 (CuSn7Zn4Pb7-C).  
**Bohrungstoleranz:** ISO D10.

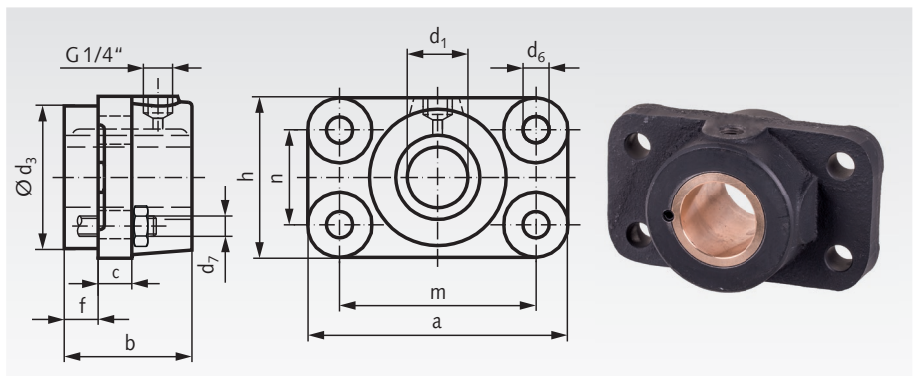

Bestellangaben: z.B.: Art.-Nr. 62124000,  
 Flanschlager DIN 503 A, 40 mm Bohrung

Artikel-Nr.	d <sub>1</sub> mm	a mm	b mm	c mm	d <sub>3</sub> <sup>h9</sup> mm	d <sub>6</sub> mm	d <sub>7</sub> mm	f mm	h mm	m mm	n mm	Gewicht kg
621 240 00	40	145	70	20	80	14	M12	20	85	110	50	3,1
621 250 00	50	175	80	25	100	18	M16	20	105	130	60	5,5
621 260 00	60	195	90	25	120	18	M16	25	125	150	80	8,1
621 270 00	70	220	100	30	140	22	M20	25	150	170	100	12,2
621 280 00	80	240	100	30	160	22	M20	30	170	190	120	14,9

Stellringe, Klemmringe Seite 679.  
 Silberstahl- und Präzisions-Wellenstahl Seite 538.

Schmierstoffgeber Seite 1024.

