

Actuator/sensor cable, PVC extension cable
PKW3M-P7X2-0,6-RSC4T/TEL

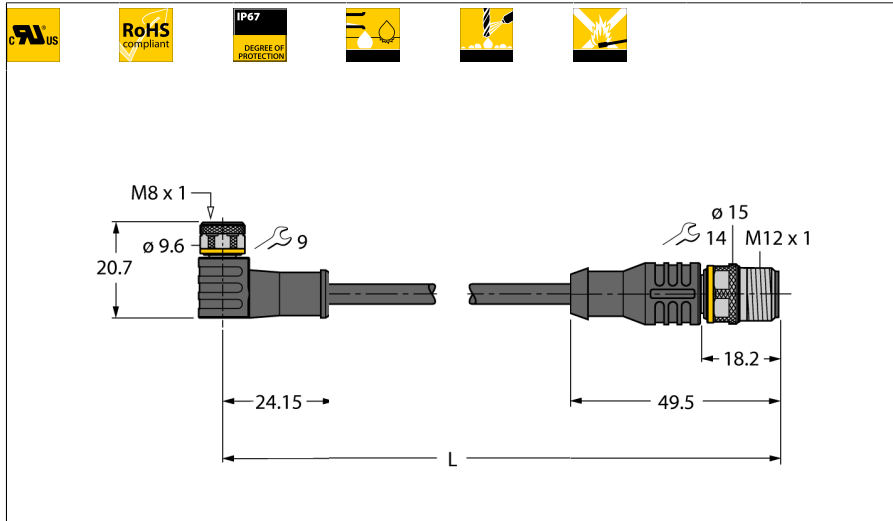

- Female M8, angled, 3-pin
- With 2-color LED (PNP, yellow, green)
- Male M12, straight, 3-pin
- Sheath material: PVC
- Sheath color: black
- Resistant to chemicals and oils
- Flame retardant
- Resistant to acids and alkaline solutions
- Resistant to microbes and hydrolysis
- LABS free
- Approval: cULus
- RoHS conform
- Protection class IP67
- Cable length: 0.6 m

Type designation PKW3M-P7X2-0,6-RSC4T/TEL
Ident no. 6625810

Connector A side
 Number of pins Female connector, M8 ⤵ 1, Angled 3
 Contacts Brass, CuZn, Gold-plated
 Contact carriers Plastic, TPU, Black
 Grip Plastic, TPU, Black
 Coupling nut/screw Brass, CuZn, Nickel-plated
 Seal Plastic, FPM/FKM
 Protection class IP67, A + B side screwed together
 Operating voltage LED green
 Display switch state LED yellow
 Mechanical lifespan > 100 Mating cycles
 Pollution degree 3
 Tightening torque 0.5 ... 0.6 Nm
 (observe max. torque of counter piece!)

Connector B side
 Number of pins Connector, M12 x 1, Straight 3 pins
 Contacts brass, CuZn, Gold-plated
 Contact carriers Plastic, TPU, Black
 Grip plastic, TPU, black
 Coupling nut/screw Brass, CuZn, Nickel-plated
 Protection class IP67, only in screwed state
 Mechanical lifespan > 100 Mating cycles
 Pollution degree 3
 Tightening torque 0.8 ... 1 Nm
 (observe max. torque of counter piece!)

General data
 Cable diameter 4.7 ± 0.20mm
 Cable length 0.6 m
 Cable quality PVC
 Cable color Black
 Core insulation PVC
 Core colors BN, BU, BK
 Core cross-section 3x0.34mm²
 Arrangement of strands 42x0.1 mm

Electrical features at +20 °C
 Current 4 A
 Rated voltage 60 V
 Insulation resistance > 30.5 MΩ/km
 Test voltage 2000 V
 Forward resistance max. 57 Ω/km

Cable Cross-section

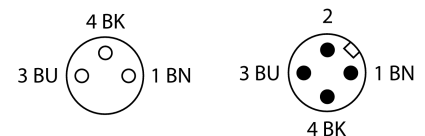
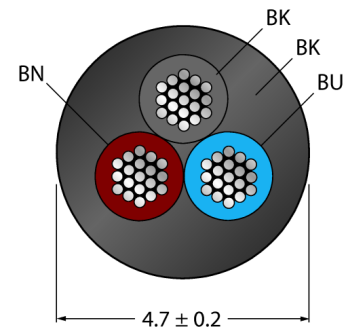

General information

Drawing depicts design version including hexagon coupling nut
 (Production date after CW11/2016).

Circuit Diagram

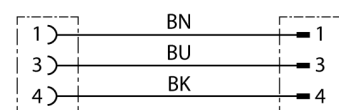

**Actuator/sensor cable, PVC
extension cable
PKW3M-P7X2-0,6-RSC4T/TEL****Mechanical and chemical properties**

Bending radius (stationary laying)	> 5 x Ø
Bending radius (flexible use)	> 10 x Ø
Ambient temperature	
Stationary	-40...+105°C
In motion	0...+80°C

**Actuator/sensor cable, PVC
extension cable
PKW3M-P7X2-0,6-RSC4T/TEL**

TURCK

Industrial
Automation

Accessories

Type code	Ident no.	Description	
Torque-Wrench-Set-AS	6936170	Torque wrench set; handles with adjustable torque 0.4-1.0 Nm, torque wrench for M8 (SW9), fork wrench for M12 (SW 14)	
BLANK-LABEL-FOR-CORDESETS-TEL-TXL	6936206	Label for TEL and TXL cables, length: 18 mm, height: 4 mm, material: polycarbonate (PC), color: white, halogen-free and flame-retardant	