

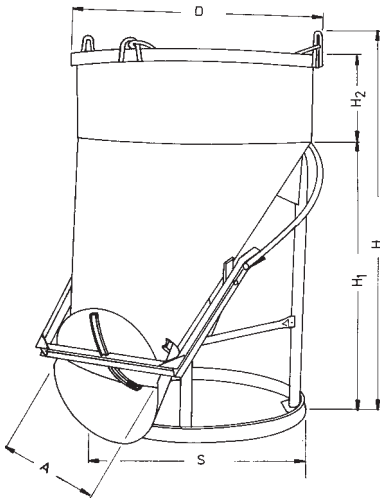

FE 1021 Betonsilo

runde Form mit seitlichem Auslauf, schwere stabile Ausführung, Verschluss mit Hebelbetätigung. Wahlweise mit Haken, abgeschweißter geprüfter Kette oder mit Bügel.



Typ	Inhalt	D	S	A	H1	H2	H	HB	Gew.
1021.1	150	820	820	340	940	100	1140	1340	80
1021.2	200	820	820	380	940	200	1240	1510	92
1021.3	250	820	820	380	940	250	1290	1590	105
1021.4	300	820	820	380	940	300	1340	1640	120
1021.5	350	970	970	420	1150	150	1400	1700	130
1021.6	375	970	970	420	1150	200	1450	1750	140
1021.7	400	970	970	420	1150	250	1500	1800	150
1021.8	500	970	970	420	1150	350	1600	2000	162
1021.9	600	970	970	420	1150	450	1700	2100	180
1021.10	750	1150	1150	480	1270	350	1720	2100	230
1021.11	800	1150	1150	480	1270	400	1770	2150	245
1021.12	1000	1300	1340	500	1330	350	1780	2300	275
1021.13	1250	1400	1440	500	1400	400	1900	2450	358
1021.14	1500	1400	1440	500	1400	600	2100	2600	405
1021.15	1750	1600	1600	500	1600	400	2100	2800	446
1021.16	2000	1600	1600	500	1600	550	2250	2950	465
1021.17	2500	1800	1800	600	1800	400	2300	3000	620
1021.18	3000	1800	1800	600	1800	600	2500	3200	760
1021.19	3500	1800	1800	600	1800	800	2700	3400	870
1021.20	4000	1800	1800	600	1800	1000	2900	3600	990



FE 1023 Betonsilo

runde Form mit seitlichem Auslauf und Schlauchanschlußstück, Verschluss mit Hebelbetätigung. Wahlweise mit Haken, angeschweißter geprüfter Kette oder mit Bügel.

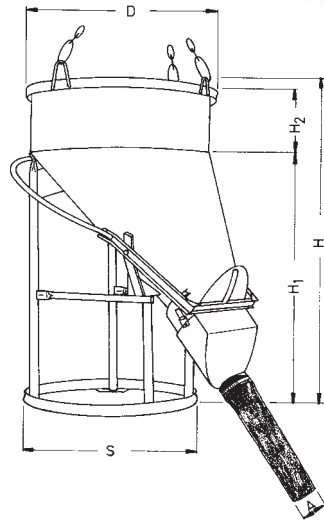

Typ	Inhalt	D	S	A	H1	H2	H	HB	Gew.
1023.3	250	820	820	wahl	1190	250	1540	1870	160
1023.6	375	970	970	wahl	1400	200	1700	2100	200
1023.8	500	970	970	wahl	1400	350	1850	2250	230
1023.10	750	1150	1150	wahl	1520	350	1970	2470	270
1023.12	1000	1300	1300	wahl	1580	350	2030	2580	310
1023.13	1250	1400	1400	wahl	1650	400	2150	2750	350
1023.14	1500	1400	1400	wahl	1650	600	2350	2950	385
1023.15	1750	1600	1600	wahl	1850	400	2350	3050	440
1023.16	2000	1600	1600	wahl	1850	550	2500	3200	500

A wahlweise: Ø 150, Ø 200, Ø 300



FE 1025 Betonsilo

liegende runde Form mit seitlichem Auslauf, schwere stabile Ausführung mit Bügel. Verschluss mit Hebelbetätigung.

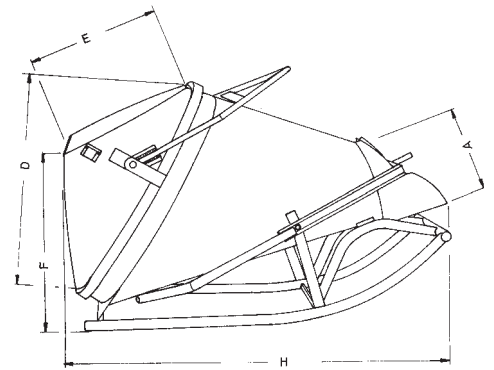

Typ	Inhalt	D	A	E	F	H	HB	Gew.
1025.1	150	740	340	600	620	1020	1390	90
1025.2	200	820	380	500	650	1400	1660	98
1025.3	250	820	380	500	730	1500	1800	115
1025.4	300	820	380	500	750	1550	1850	120
1025.5	350	820	380	500	770	1600	1900	140
1025.6	375	1150	420	650	800	1820	2400	185
1025.7	400	1150	420	650	820	1850	2430	195
1025.8	500	1150	420	650	850	1900	2480	220
1025.9	600	1150	420	650	870	1930	2510	240
1025.10	750	1150	420	700	900	1960	2540	320
1025.11	800	1150	420	700	940	1980	2560	350
1025.12	1000	1150	420	700	980	2200	2780	420
1025.13	1250	1400	500	850	1150	2400	3100	535
1025.14	1500	1400	500	850	1200	2500	3200	580
1025.15	1750	1400	500	850	1250	2600	3300	795
1025.16	2000	1400	500	850	1300	2700	3400	820
1025.17	2500	1600	600	900	1450	2800	3600	1020
1025.18	3000	1600	600	900	1500	3000	3800	1160
1025.19	3500	1600	600	900	1550	3200	4000	1260
1025.20	4000	1600	600	900	1600	3400	4200	1320