

FEATURES

- Fast access time : 12/15ns
- Low power consumption:
Operating current : 50/40mA (TYP.)
Standby current : 1mA (TYP.)
- Single 4.5V ~ 5.5V power supply
- All inputs and outputs TTL compatible
- Fully static operation
- Tri-state output
- Data retention voltage : 2.0V (MIN.)
- **Lead free and green package available**
- Package : 32-pin 300 mil SOJ
32-pin 8mm x 20mm TSOP-I
32-pin 8mm x 13.4mm STSOP

GENERAL DESCRIPTION

The LY611024 is a 1,048,576-bit low power CMOS static random access memory organized as 131,072 words by 8 bits. It is fabricated using very high performance, high reliability CMOS technology. Its standby current is stable within the range of operating temperature.

The LY611024 is well designed for very high speed system applications, and particularly well suited for battery back-up nonvolatile memory application.

The LY611024 operates from a single power supply of 4.5V ~ 5.5V and all inputs and outputs are fully TTL compatible

PRODUCT FAMILY

Product Family	Operating Temperature	Vcc Range	Speed	Power Dissipation	
				Standby(IsB1,TYP.)	Operating(Icc,TYP.)
LY611024	0 ~ 70°C	4.5 ~ 5.5V	12/15ns	1mA	50/40mA
LY611024(E)	-20 ~ 80°C	4.5 ~ 5.5V	12/15ns	1mA	50/40mA
LY611024(I)	-40 ~ 85°C	4.5 ~ 5.5V	12/15ns	1mA	50/40mA

FUNCTIONAL BLOCK DIAGRAM

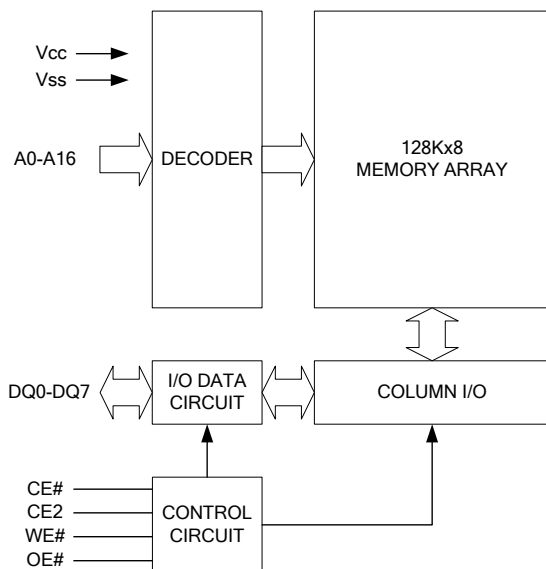

PIN DESCRIPTION

SYMBOL	DESCRIPTION
A0 - A16	Address Inputs
DQ0 - DQ7	Data Inputs/Outputs
CE#, CE2	Chip Enable Inputs
WE#	Write Enable Input
OE#	Output Enable Input
Vcc	Power Supply
Vss	Ground
NC	No Connection



PIN CONFIGURATION

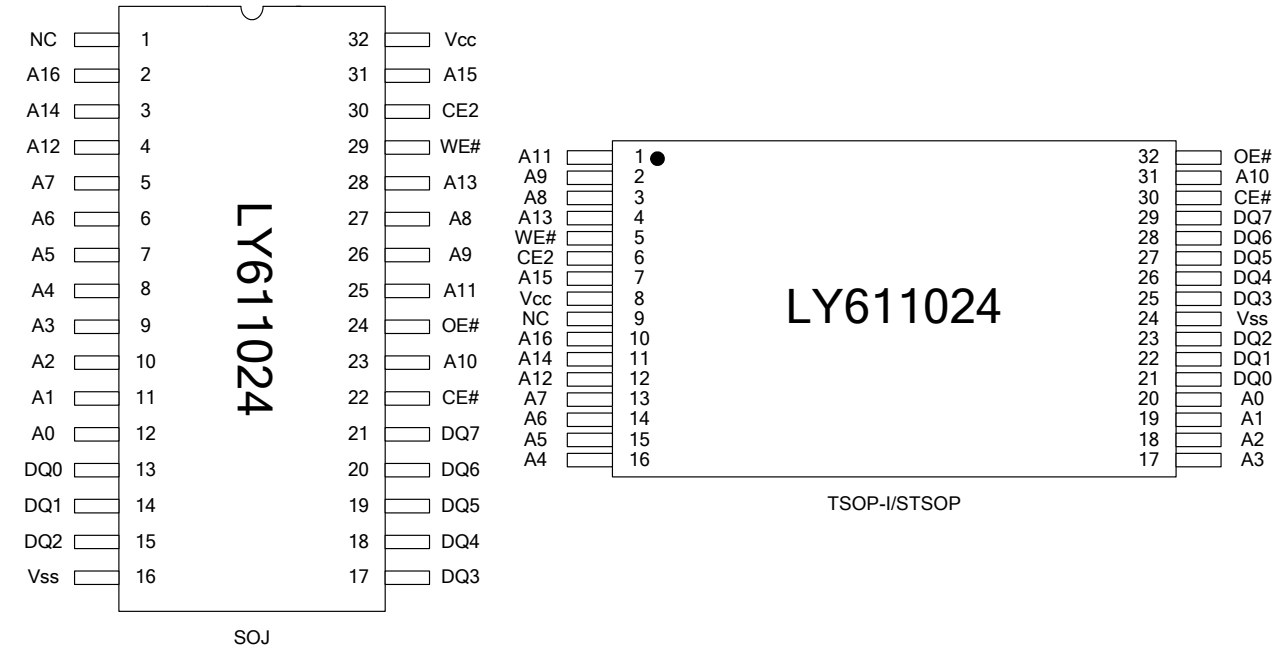

ABSOLUTE MAXIMUM RATINGS*

PARAMETER	SYMBOL	RATING	UNIT
Terminal Voltage with Respect to V _{SS}	V _{TERM}	-0.5 to 7.0	V
Operating Temperature	T _A	0 to 70(C grade)	°C
		-20 to 80(E grade)	°C
		-40 to 85(I grade)	°C
Storage Temperature	T _{STG}	-65 to 150	°C
Power Dissipation	P _D	1	W
DC Output Current	I _{OUT}	50	mA
Soldering Temperature (under 10 sec)	T _{SOLDER}	260	°C

*Stresses greater than those listed under "Absolute Maximum Ratings" may cause permanent damage to the device. This is a stress rating only and functional operation of the device or any other conditions above those indicated in the operational sections of this specification is not implied. Exposure to the absolute maximum rating conditions for extended period may affect device reliability.

TRUTH TABLE

MODE	CE#	CE2	OE#	WE#	I/O OPERATION	SUPPLY CURRENT
Standby	H	X	X	X	High-Z	I _{SB} , I _{SB1}
	X	L	X	X	High-Z	I _{SB} , I _{SB1}
Output Disable	L	H	H	H	High-Z	I _{CC}
Read	L	H	L	H	D _{OUT}	I _{CC}
Write	L	H	X	L	D _{IN}	I _{CC}

Note: H = V_{IH}, L = V_{IL}, X = Don't care.



DC ELECTRICAL CHARACTERISTICS

PARAMETER	SYMBOL	TEST CONDITION	MIN.	TYP. ⁴	MAX.	UNIT	
Supply Voltage	V _{CC}		4.5	5.0	5.5	V	
Input High Voltage	V _{IH} ¹		2.4	-	V _{CC} +0.5	V	
Input Low Voltage	V _{IL} ²		- 0.5	-	0.8	V	
Input Leakage Current	I _{LI}	V _{CC} ≥ V _{IN} ≥ V _{SS}	- 1	-	1	μA	
Output Leakage Current	I _{LO}	V _{CC} ≥ V _{OUT} ≥ V _{SS} , Output Disabled	- 1	-	1	μA	
Output High Voltage	V _{OH}	I _{OH} = -4mA	2.4	-	-	V	
Output Low Voltage	V _{OL}	I _{OL} = 8mA	-	-	0.4	V	
Average Operating Power supply Current	I _{CC}	Cycle time = Min. CE# = V _{IL} and CE2 = V _{IH} , I _{I/O} = 0mA	- 12	-	50	80	mA
			- 15	-	40	65	mA
Standby Power Supply Current	I _{SB}	CE# = V _{IH} or CE2 = V _{IL}	-	3	20	mA	
	I _{SB1}	CE# ≥ V _{CC} -0.2V or CE2 ≤ 0.2V	-	1 ⁵	5	mA	

Notes:

- V_{IH}(max) = V_{CC} + 3.0V for pulse width less than 10ns.
- V_{IL}(min) = V_{SS} - 3.0V for pulse width less than 10ns.
- Over/Undershoot specifications are characterized, not 100% tested.
- Typical values are included for reference only and are not guaranteed or tested.
Typical valued are measured at V_{CC} = V_{CC}(TYP.) and T_A = 25°C
- 20μA for special request.

CAPACITANCE (T_A = 25°C, f = 1.0MHz)

PARAMETER	SYMBOL	MIN.	MAX	UNIT
Input Capacitance	C _{IN}	-	6	pF
Input/Output Capacitance	C _{I/O}	-	8	pF

Note : These parameters are guaranteed by device characterization, but not production tested.

AC TEST CONDITIONS

Input Pulse Levels	0.2V to V _{CC} - 0.2V
Input Rise and Fall Times	3ns
Input and Output Timing Reference Levels	1.5V
Output Load	C _L = 30pF + 1TTL, I _{OH} /I _{OL} = -4mA/8mA



AC ELECTRICAL CHARACTERISTICS

(1) READ CYCLE

PARAMETER	SYM.	LY611024-12		LY611024-15		UNIT
		MIN.	MAX.	MIN.	MAX.	
Read Cycle Time	t _{RC}	12	-	15	-	ns
Address Access Time	t _{AA}	-	12	-	15	ns
Chip Enable Access Time	t _{ACE}	-	12	-	15	ns
Output Enable Access Time	t _{OE}	-	6	-	7	ns
Chip Enable to Output in Low-Z	t _{CLZ} *	3	-	4	-	ns
Output Enable to Output in Low-Z	t _{OLZ} *	0	-	0	-	ns
Chip Disable to Output in High-Z	t _{CHZ} *	-	6	-	7	ns
Output Disable to Output in High-Z	t _{OHZ} *	-	6	-	7	ns
Output Hold from Address Change	t _{OH}	3	-	3	-	ns

(2) WRITE CYCLE

PARAMETER	SYM.	LY611024-12		LY611024-15		UNIT
		MIN.	MAX.	MIN.	MAX.	
Write Cycle Time	t _{WC}	12	-	15	-	ns
Address Valid to End of Write	t _{AW}	10	-	12	-	ns
Chip Enable to End of Write	t _{CW}	10	-	12	-	ns
Address Set-up Time	t _{AS}	0	-	0	-	ns
Write Pulse Width	t _{WP}	9	-	10	-	ns
Write Recovery Time	t _{WR}	0	-	0	-	ns
Data to Write Time Overlap	t _{DW}	7	-	8	-	ns
Data Hold from End of Write Time	t _{DH}	0	-	0	-	ns
Output Active from End of Write	t _{OW} *	3	-	4	-	ns
Write to Output in High-Z	t _{WHZ} *	-	7	-	8	ns

*These parameters are guaranteed by device characterization, but not production tested.



TIMING WAVEFORMS

READ CYCLE 1 (Address Controlled) (1,2)

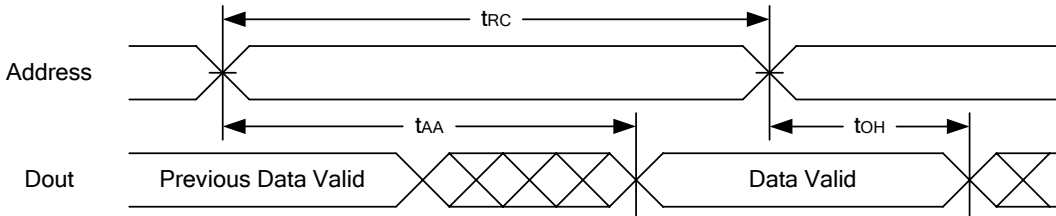

READ CYCLE 2 (CE# and CE2 and OE# Controlled) (1,3,4,5)

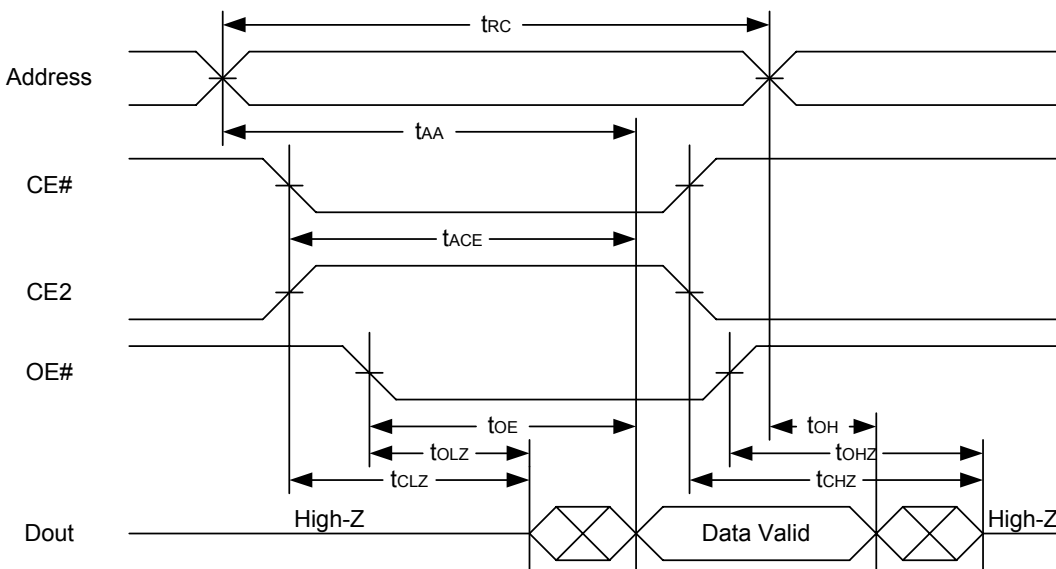

Notes :

1. WE# is high for read cycle.
2. Device is continuously selected OE# = low, CE# = low, CE2 = high.
3. Address must be valid prior to or coincident with CE# = low, CE2 = high; otherwise tAA is the limiting parameter.
4. tCLZ, tOLZ, tCHZ and tOHZ are specified with CL = 5pF. Transition is measured ±500mV from steady state.
5. At any given temperature and voltage condition, tCHZ is less than tCLZ, tOHZ is less than tOLZ.



WRITE CYCLE 1 (WE# Controlled) (1,2,3,5,6)

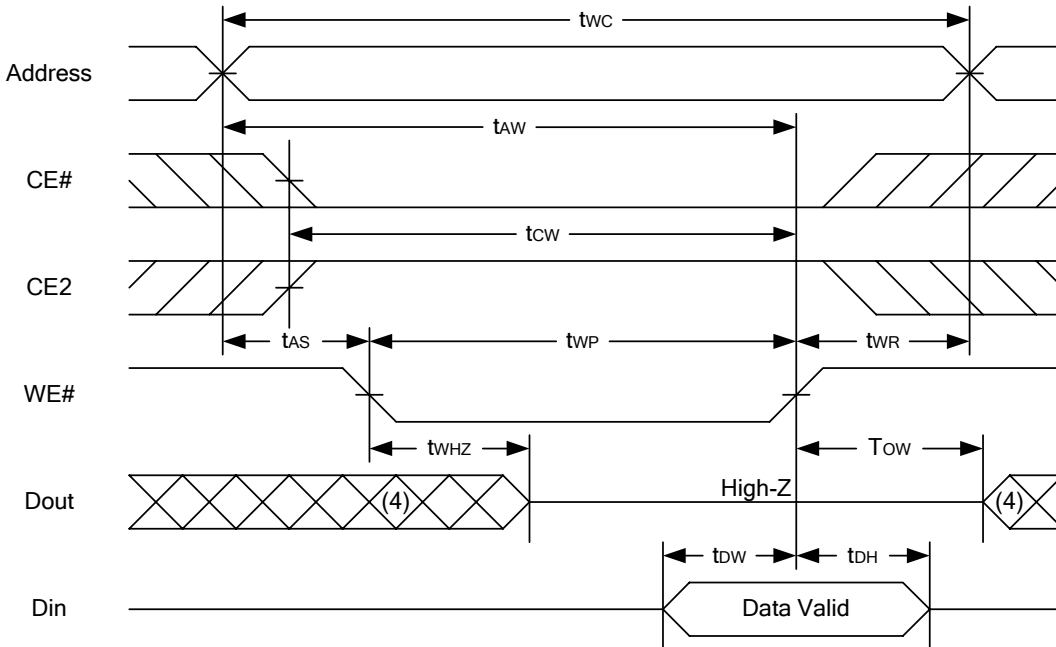

WRITE CYCLE 2 (CE# and CE2 Controlled) (1,2,5,6)

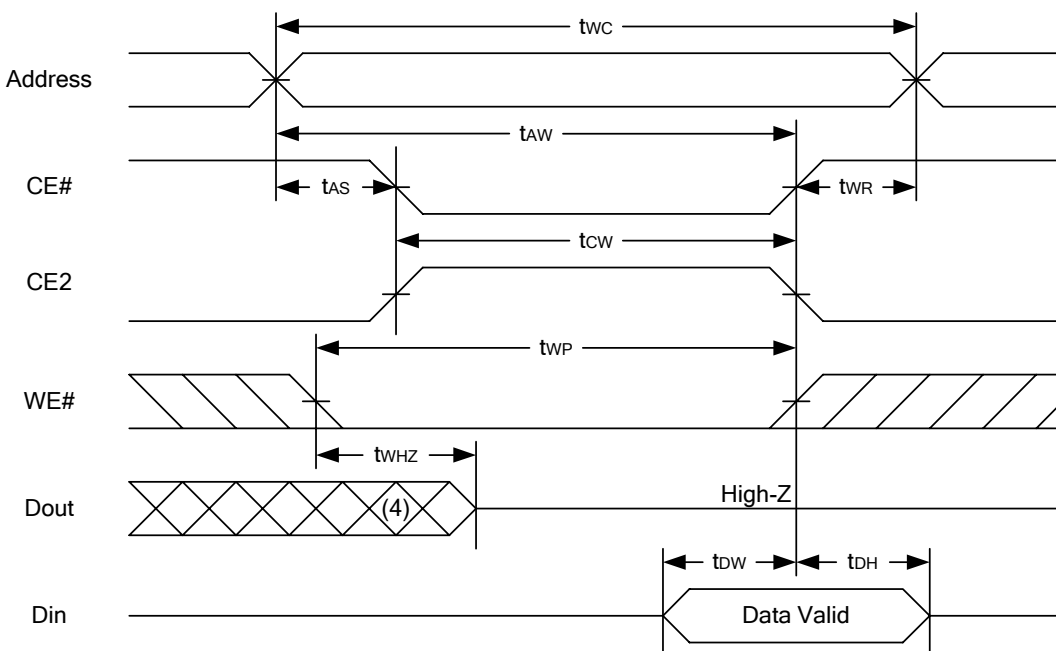

Notes :

1. WE#, CE# must be high or CE2 must be low during all address transitions.
2. A write occurs during the overlap of a low CE#, high CE2, low WE#.
3. During a WE#-controlled write cycle with OE# low, twp must be greater than twhz + tdw to allow the drivers to turn off and data to be placed on the bus.
4. During this period, I/O pins are in the output state, and input signals must not be applied.
5. If the CE# low transition and CE2 high transition occurs simultaneously with or after WE# low transition, the outputs remain in a high impedance state.
6. tow and twhz are specified with CL = 5pF. Transition is measured ±500mV from steady state.



DATA RETENTION CHARACTERISTICS

PARAMETER	SYMBOL	TEST CONDITION	MIN.	TYP.	MAX.	UNIT
Vcc for Data Retention	V _{DR}	CE# ≥ V _{CC} - 0.2V or CE2 ≤ 0.2V	2.0	-	5.5	V
Data Retention Current	I _{DR}	V _{CC} = 2.0V CE# ≥ V _{CC} - 0.2V or CE2 ≤ 0.2V	-	0.01	3	mA
Chip Disable to Data Retention Time	t _{CDR}	See Data Retention Waveforms (below)	0	-	-	ns
Recovery Time	t _R		t _{RC*}	-	-	ns

t_{RC*} = Read Cycle Time

DATA RETENTION WAVEFORM

Low Vcc Data Retention Waveform (1) (CE# controlled)

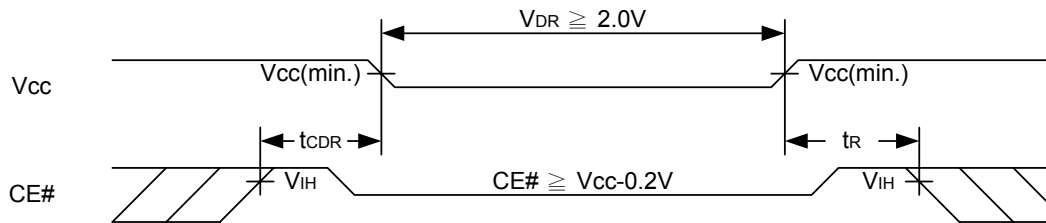

Low Vcc Data Retention Waveform (2) (CE2 controlled)

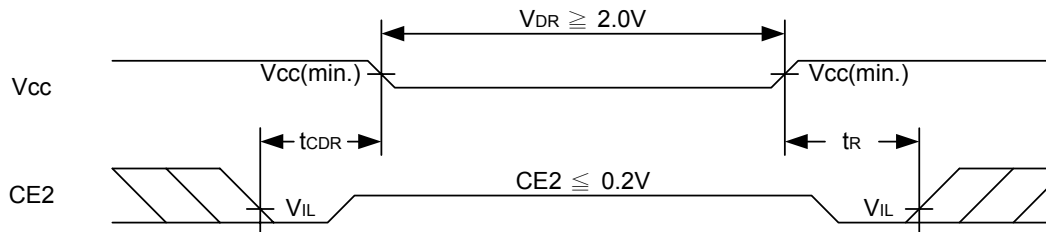



PACKAGE OUTLINE DIMENSION

32 pin 300mil SOJ Package Outline Dimension

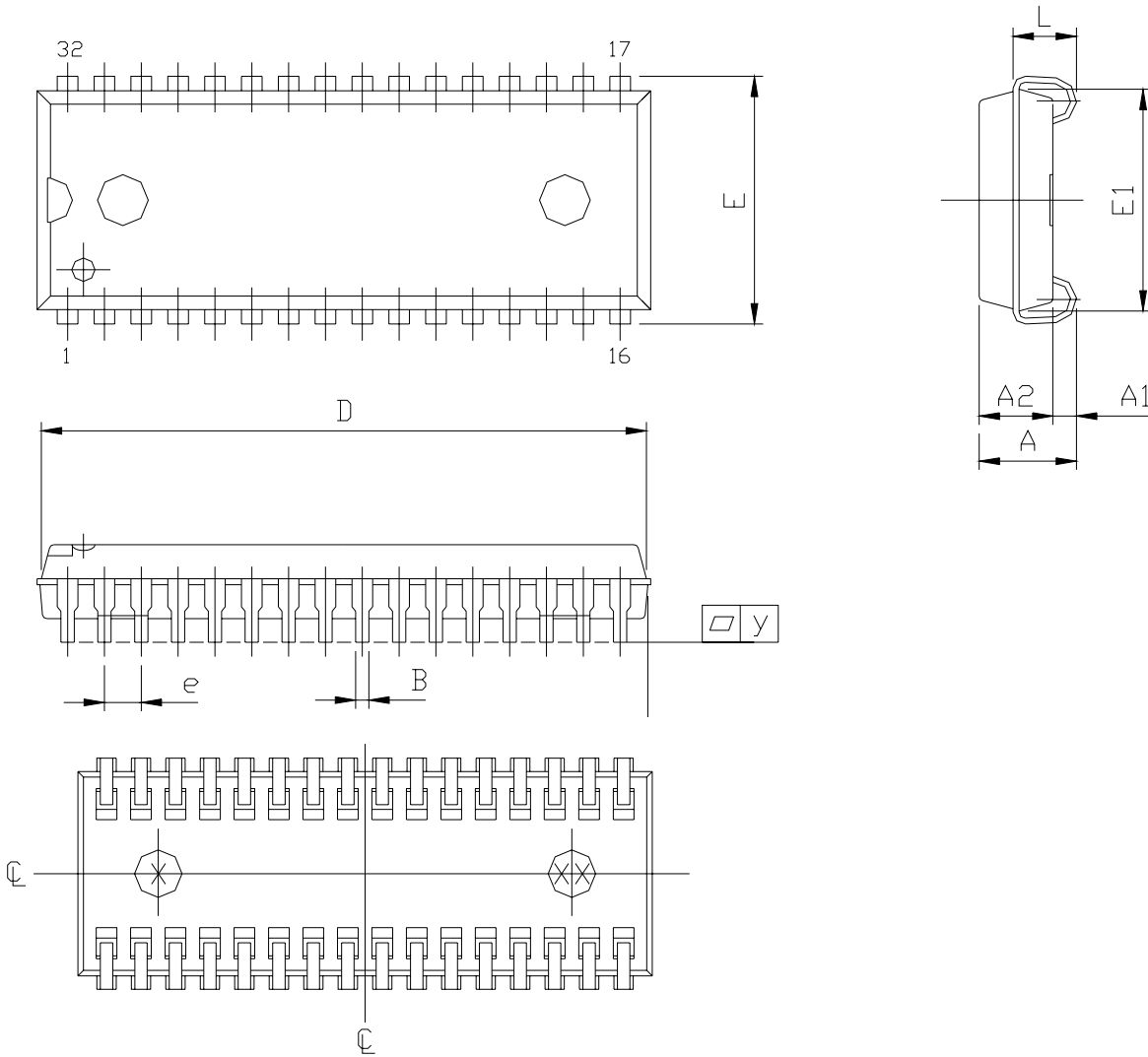

SYMBOL	UNIT	INCH(BASE)	MM(REF)
A		0.148 (MAX)	3.759 (MAX)
A1		0.026 (MIN)	0.660 (MIN)
A2		0.100 ±0.005	2.540 ±0.127
B		0.018 (TYP)	0.457 (TYP)
D		0.830 (MAX)	21.082 (MAX)
E		0.335 (TYP)	8.509 (TYP)
E1		0.300 ±0.005	7.620 ±0.127
e		0.050 (TYP)	1.270 (TYP)
L		0.086 ±0.010	2.184 ±0.254
y		0.003 (MAX)	0.076 (MAX)



32 pin 8mm x 20mm TSOP-I Package Outline Dimension

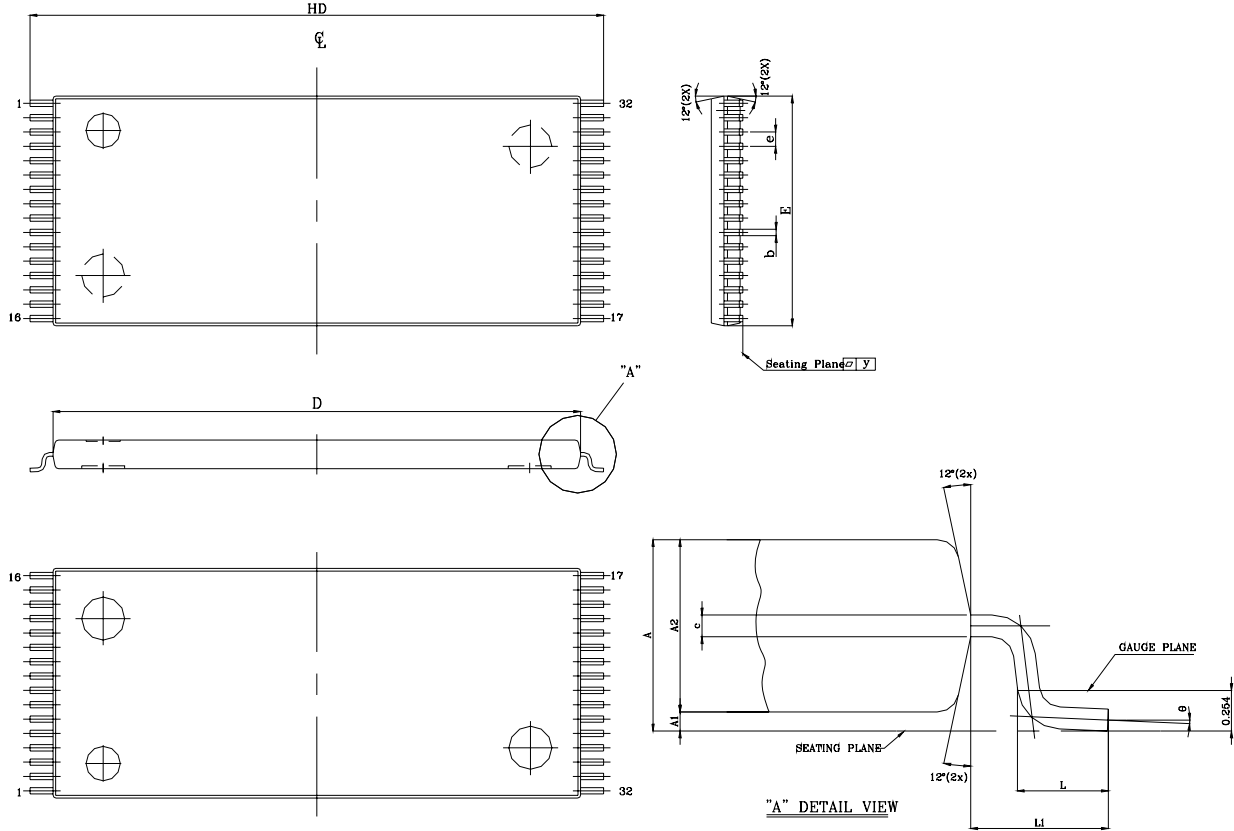

SYM.	UNIT	INCH(BASE)	MM(REF)
A		0.047 (MAX)	1.20 (MAX)
A1		0.004 ±0.002	0.10 ±0.05
A2		0.039 ±0.002	1.00 ±0.05
b		0.008 + 0.002 - 0.001	0.20 + 0.05 - 0.03
c		0.005 (TYP)	0.127 (TYP)
D		0.724 ±0.004	18.40 ±0.10
E		0.315 ±0.004	8.00 ±0.10
e		0.020 (TYP)	0.50 (TYP)
HD		0.787 ±0.008	20.00 ±0.20
L		0.0197 ±0.004	0.50 ±0.10
L1		0.0315 ±0.004	0.08 ±0.10
y		0.003 (MAX)	0.076 (MAX)
θ		0°~5°	0°~5°



32 pin 8mm x 13.4mm STSOP Package Outline Dimension

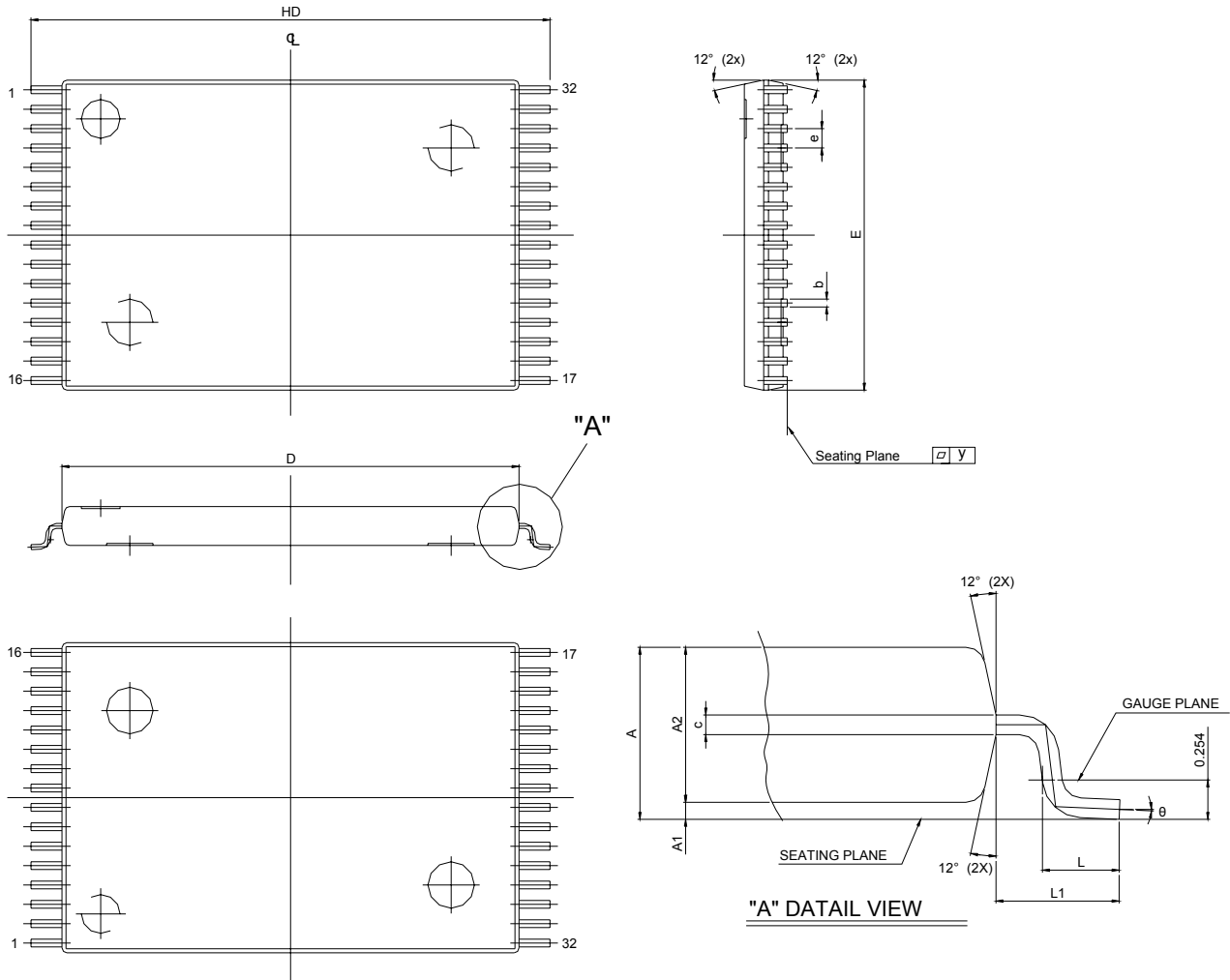

SYM.	UNIT	INCH(BASE)	MM(REF)
A		0.049 (MAX)	1.25 (MAX)
A1		0.005 ±0.002	0.130 ±0.05
A2		0.039 ±0.002	1.00 ±0.05
b		0.008 ±0.01	0.20±0.025
c		0.005 (TYP)	0.127 (TYP)
D		0.465 ±0.004	11.80 ±0.10
E		0.315 ±0.004	8.00 ±0.10
e		0.020 (TYP)	0.50 (TYP)
HD		0.528±0.008	13.40 ±0.20.
L		0.0197 ±0.004	0.50 ±0.10
L1		0.0315 ±0.004	0.8 ±0.10
y		0.003 (MAX)	0.076 (MAX)
Θ		0°~5°	0°~5°



ORDERING INFORMATION

LY611024 V W - XX Z

Z : Temperature Range
Blank : (Commercial) 0°C ~ 70°C
E : (Extend) -20°C ~ 80°C
I : (Industrial) -40°C ~ 85°C

XX : Access Time(Speed)

W : Lead Information
N : Normal
L : Lead Free

V : Package Type
J : 32-pin 300 mil SOJ
L : 32-pin 8 mm x 20 mm TSOP-I
R : 32-pin 8 mm x 13.4 mm STSOP



Lyontek Inc.

LY611024

Rev. 1.2

128K X 8 BIT HIGH SPEED CMOS SRAM

THIS PAGE IS LEFT BLANK INTENTIONALLY.