



Contactor, 3-pole + 2 N/O + 2 N/C, 1200 A/AC1

Part no. DILH1200/22(RAW250)
Catalog No. 151242
Eaton Catalog No. XTCEC12P22B

Delivery program

Product range			Contactors
Application			Mains contactors for resistive loads from 1000 A
Subrange			AC -1 contactors greater than 1000 A
Utilization category			AC-1: Non-inductive or slightly inductive loads, resistance furnaces
Connection technique			Screw connection
Rated operational current			
AC-1			
Conventional free air thermal current, 3 pole, 50 - 60 Hz			
Open			
at 40 °C	$I_{th} = I_e$	A	1450
Conventional free air thermal current, 1 pole			
open	I_{th}	A	3000
Contact sequence			
For use with			DILM820-XHI...
Actuating voltage			RAW 250: 230 - 250 V 50 - 60 Hz/230 - 350 V DC
Voltage AC/DC			AC and DC operation
Auxiliary contacts			
possible variants at auxiliary contact module fitting options			on the side: 2 x DILM820-XHI11(V)-SI; 2 x DILM820-XHI11-SA
Side mounting auxiliary contacts			
Instructions			integrated suppressor circuit in actuating electronics 660 V, 690 V or 1000 V: not directly reversing

Technical data

General			
Standards			IEC/EN 60947, VDE 0660, UL, CSA, CCC
Lifespan, mechanical			
AC operated	Operations	$\times 10^6$	3
DC operated	Operations	$\times 10^6$	3
Operating frequency, mechanical			
AC operated	Operations/h		1000
DC operated	Operations/h		1000
Climatic proofing			Damp heat, constant, to IEC 60068-2-78 Damp heat, cyclic, to IEC 60068-2-30
Ambient temperature			
Open		°C	-40 - +60
Enclosed		°C	-40 - +40
Storage		°C	-40 - +80
Mounting position			
Mechanical shock resistance (IEC/EN 60068-2-27)			
Half-sinusoidal shock, 10 ms			
Main contacts			

N/O contact		g	10
Auxiliary contacts			
N/O contact		g	10
N/C contact		g	8
Degree of Protection			IP00
Weight		kg	14.4
Terminal capacity main cable			
Busbar	Width	mm	80
Main cable connection screw/bolt			M12
Tightening torque		Nm	35
Terminal capacity control circuit cables			
Solid		mm ²	1 x (0.75 - 2.5) 2 x (0.75 - 2.5)
Flexible with ferrule		mm ²	1 x (0.75 - 2.5) 2 x (0.75 - 2.5)
Solid or stranded		AWG	2 x (18 - 12) 18 - 14
Stripping length		mm	10
Control circuit cable connection screw/bolt			M3.5
Tightening torque		Nm	1.2
Tool			
Main cable			
Width across flats		mm	18
Control circuit cables			
Pozidriv screwdriver		Size	2
Standard screwdriver		mm	0.8 x 5.5/1 x 6

Main conducting paths

Rated impulse withstand voltage	U_{imp}	V AC	8000
Overvoltage category/pollution degree			III/3
Rated insulation voltage	U_i	V AC	1000
Rated operational voltage	U_e	V AC	1000
Safe isolation to EN 61140			
between coil and contacts		V AC	500
between the contacts		V AC	500
Making capacity (p.f. to IEC/EN 60947)		A	9840
Breaking capacity			
220 V 230 V		A	8200
380 V 400 V		A	8200
500 V		A	8200
660 V 690 V		A	8200
1000 V		A	5800
Component lifespan			
			AC1: See → Engineering, characteristic curves

AC

AC-1			
Rated operational current			
Conventional free air thermal current, 3 pole, 50 - 60 Hz			
Open			
at 40 °C	$I_{th} = I_e$	A	1450
at 50 °C	$I_{th} = I_e$	A	1315
at 55 °C	$I_{th} = I_e$	A	1250
at 60 °C	$I_{th} = I_e$	A	1200
Conventional free air thermal current, 1 pole			
Note			at maximum permissible ambient air temperature
open	I_{th}	A	3000

Current heat loss

3 pole, at I_{th} (60°)	W	135
---------------------------	---	-----

Magnet systems

Voltage tolerance		
U_S		230 - 250 V 50/60 Hz 230 - 350 V DC
AC operated	Pick-up	$x U_S$ 0.7 x $U_{S\ min}$ - 1.15 x $U_{S\ max}$
DC operated	Pick-up	$x U_S$ 0.7 x $U_{S\ min}$ - 1.15 x $U_{S\ max}$
AC operated	Drop-out	$x U_S$ 0.2 x $U_{S\ max}$ - 0.6 x $U_{S\ min}$
DC operated	Drop-out	$x U_S$ 0.2 x $U_{S\ max}$ - 0.6 x $U_{S\ min}$
Power consumption of the coil in a cold state and $1.0 \times U_C$		
Note on power consumption		Control transformer with $u_k \leq 0.7$
Pull-in power	Pick-up	VA 800
Pull-in power	Pick-up	W 700
Sealing power	Sealing	CO 6.5
Sealing power	Sealing	VA 7.5
Sealing power	Sealing	W 6.5
Duty factor	% DF	100
Changeover time at 100 % U_C (recommended value)		
Main contacts		
Closing delay	ms	70
Opening delay	ms	40
Behaviour in marginal and transitional conditions		
Sealing		
Voltage interruptions		
$(0 \dots 0.2 \times U_{C\ min}) \leq 10\ ms$		Time is bridged successfully
$(0 \dots 0.2 \times U_{C\ min}) > 10\ ms$		Drop-out of the contactor
Voltage drops		
$(0.2 \dots 0.6 \times U_{C\ min}) \leq 12\ ms$		Time is bridged successfully
$(0.2 \dots 0.6 \times U_{C\ min}) > 12\ ms$		Drop-out of the contactor
$(0.6 \dots 0.7 \times U_{C\ min})$		Contactor remains switched on
Excess voltage		
$(1.15 \dots 1.3 \times U_{C\ max})$		Contactor remains switched on
Pick-up phase		
$(0 \dots 0.7 \times U_{C\ min})$		Contactor does not switch on
$(0.7 \times U_{C\ min} \dots 1.15 \times U_{C\ max})$		Contactor switches on with certainty
Admissible transitional contact resistance (of the external control circuit device when actuating A11)	mΩ	≤ 500
PLC signal level (A3 - A4) to IEC/EN 61131-2 (type 2)		
High	V	15
Low	V	5

Electromagnetic compatibility (EMC)

Electromagnetic compatibility		This product is designed for operation in industrial environments (environment 2). The use in residential environments (environment 1) could cause electrical interference so that addition suppression must be planned.
-------------------------------	--	--

Rating data for approved types

Switching capacity		
Maximum motor rating		
General use	A	1380
Auxiliary contacts		
Pilot Duty		
AC operated		A600
DC operated		P300
General Use		
AC	V	600

AC	A	15
DC	V	250
DC	A	1
Special Purpose Ratings		
Resistance Air Heating		
480V 60Hz 3phase, 277V 60Hz 1phase	A	1380
600V 60Hz 3phase, 347V 60Hz 1phase	A	1380

Design verification as per IEC/EN 61439

Technical data for design verification			
Rated operational current for specified heat dissipation	I_n	A	1200
Heat dissipation per pole, current-dependent	P_{vid}	W	47
Equipment heat dissipation, current-dependent	P_{vid}	W	0
Static heat dissipation, non-current-dependent	P_{vs}	W	6.5
Heat dissipation capacity	P_{diss}	W	0
Operating ambient temperature max.		°C	-40
Operating ambient temperature max.		°C	60
IEC/EN 61439 design verification			
10.2 Strength of materials and parts			
10.2.2 Corrosion resistance			Meets the product standard's requirements.
10.2.3.1 Verification of thermal stability of enclosures			Meets the product standard's requirements.
10.2.3.2 Verification of resistance of insulating materials to normal heat			Meets the product standard's requirements.
10.2.3.3 Verification of resistance of insulating materials to abnormal heat and fire due to internal electric effects			Meets the product standard's requirements.
10.2.4 Resistance to ultra-violet (UV) radiation			Meets the product standard's requirements.
10.2.5 Lifting			Does not apply, since the entire switchgear needs to be evaluated.
10.2.6 Mechanical impact			Does not apply, since the entire switchgear needs to be evaluated.
10.2.7 Inscriptions			Meets the product standard's requirements.
10.3 Degree of protection of ASSEMBLIES			Does not apply, since the entire switchgear needs to be evaluated.
10.4 Clearances and creepage distances			Meets the product standard's requirements.
10.5 Protection against electric shock			Does not apply, since the entire switchgear needs to be evaluated.
10.6 Incorporation of switching devices and components			Does not apply, since the entire switchgear needs to be evaluated.
10.7 Internal electrical circuits and connections			Is the panel builder's responsibility.
10.8 Connections for external conductors			Is the panel builder's responsibility.
10.9 Insulation properties			
10.9.2 Power-frequency electric strength			Is the panel builder's responsibility.
10.9.3 Impulse withstand voltage			Is the panel builder's responsibility.
10.9.4 Testing of enclosures made of insulating material			Is the panel builder's responsibility.
10.10 Temperature rise			The panel builder is responsible for the temperature rise calculation. Eaton will provide heat dissipation data for the devices.
10.11 Short-circuit rating			Is the panel builder's responsibility. The specifications for the switchgear must be observed.
10.12 Electromagnetic compatibility			Is the panel builder's responsibility. The specifications for the switchgear must be observed.
10.13 Mechanical function			The device meets the requirements, provided the information in the instruction leaflet (IL) is observed.

Technical data ETIM 6.0

Low-voltage industrial components (EG000017) / Power contactor, AC switching (EC000066)			
Electric engineering, automation, process control engineering / Low-voltage switch technology / Contactor (LV) / Power contactor, AC switching (ecl@ss8.1-27-37-10-03 [AAB718012])			
Rated control supply voltage U_s at AC 50HZ	V		230 - 250
Rated control supply voltage U_s at AC 60HZ	V		230 - 250
Rated control supply voltage U_s at DC	V		230 - 350
Voltage type for actuating			AC/DC
Rated operation current I_e at AC-1, 400 V	A		1470
Rated operation current I_e at AC-3, 400 V	A		0
Rated operation power at AC-3, 400 V	kW		0

Rated operation current I _e at AC-4, 400 V	A	0
Rated operation power I _e at AC-4, 400 V	kW	0
Modular version		No
Number of auxiliary contacts as normally open contact		2
Number of auxiliary contacts as normally closed contact		2
Type of electrical connection of main circuit		Screw connection
Number of normally closed contacts as main contact		0
Number of main contacts as normally open contact		3

Approvals

Product Standards		IEC/EN 60947-4-1; UL 60947-4-1; CSA - C22.2 No. 60947-4-1-14; CE marking
UL File No.		E29096
UL Category Control No.		NLDX
CSA File No.		012528
CSA Class No.		3211-04
North America Certification		UL listed, CSA certified
Specially designed for North America		No

Characteristics

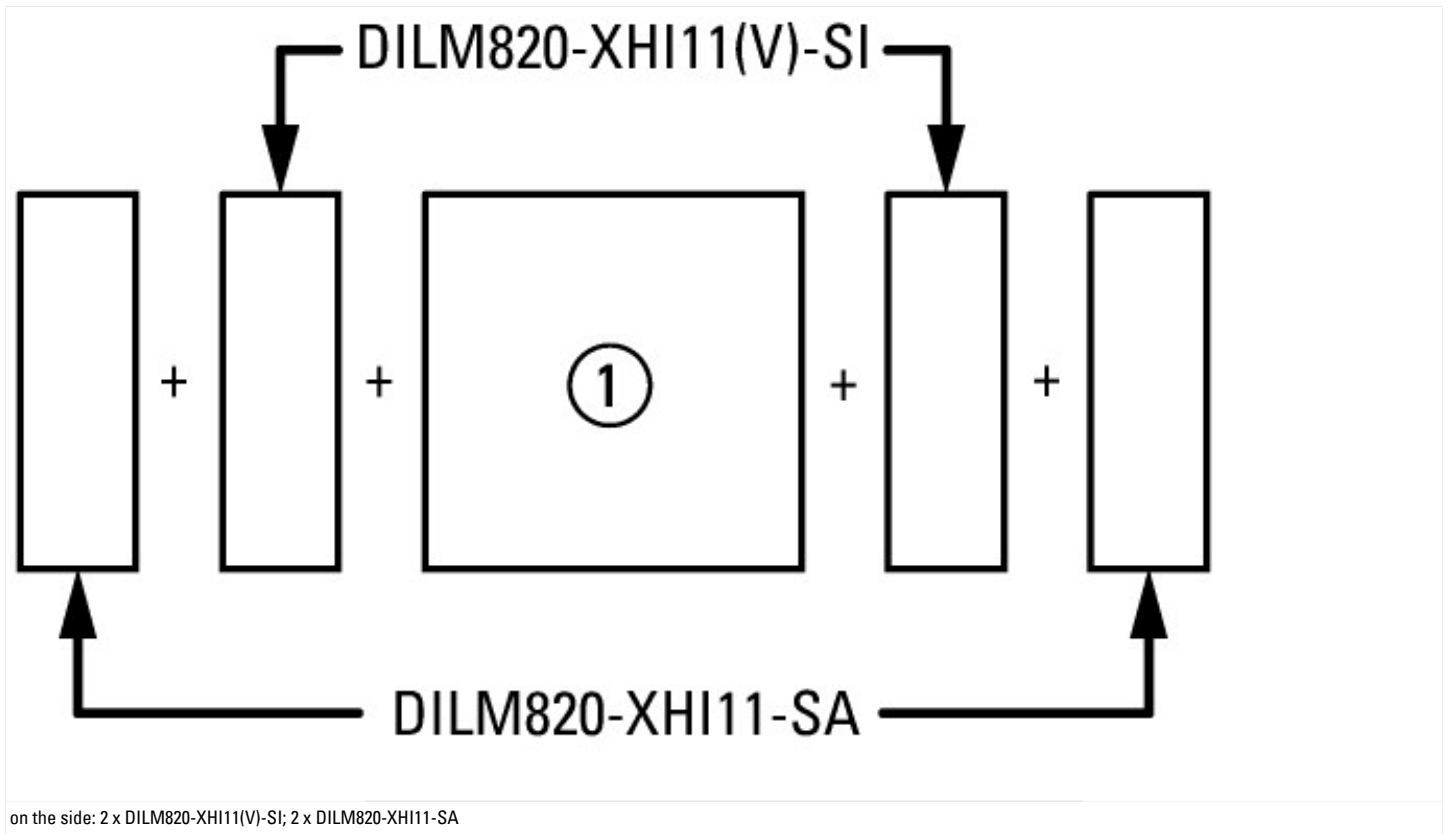

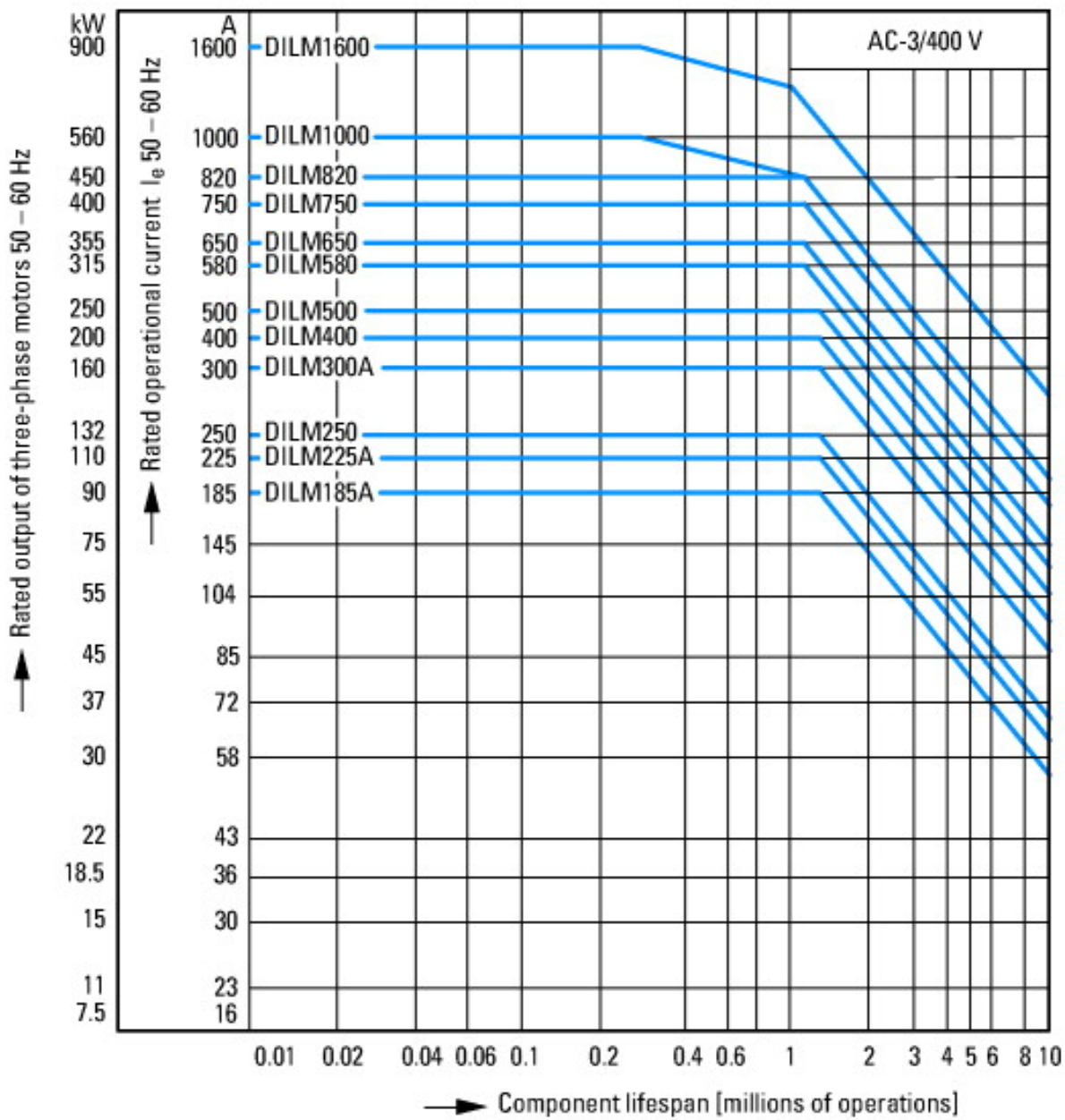

- Normal switching duty
- Normal AC induction motor
- Operating characteristics
- Switch on: from stop
- Switch off: during run
- Electrical characteristics:
- Switch on: up to 6 x Rated motor current
- Switch off: up to 1 x Rated motor current
- Utility category
- 100 % AC-3
- Typical Applications
- Compressors
- Lifts
- Mixers
- Pumps
- Escalators
- Agitators
- fan
- Conveyor belts
- Centrifuges
- Hinged flaps
- Bucket-elevator
- Air-conditioning systems
- General drives for manufacturing and processing machines

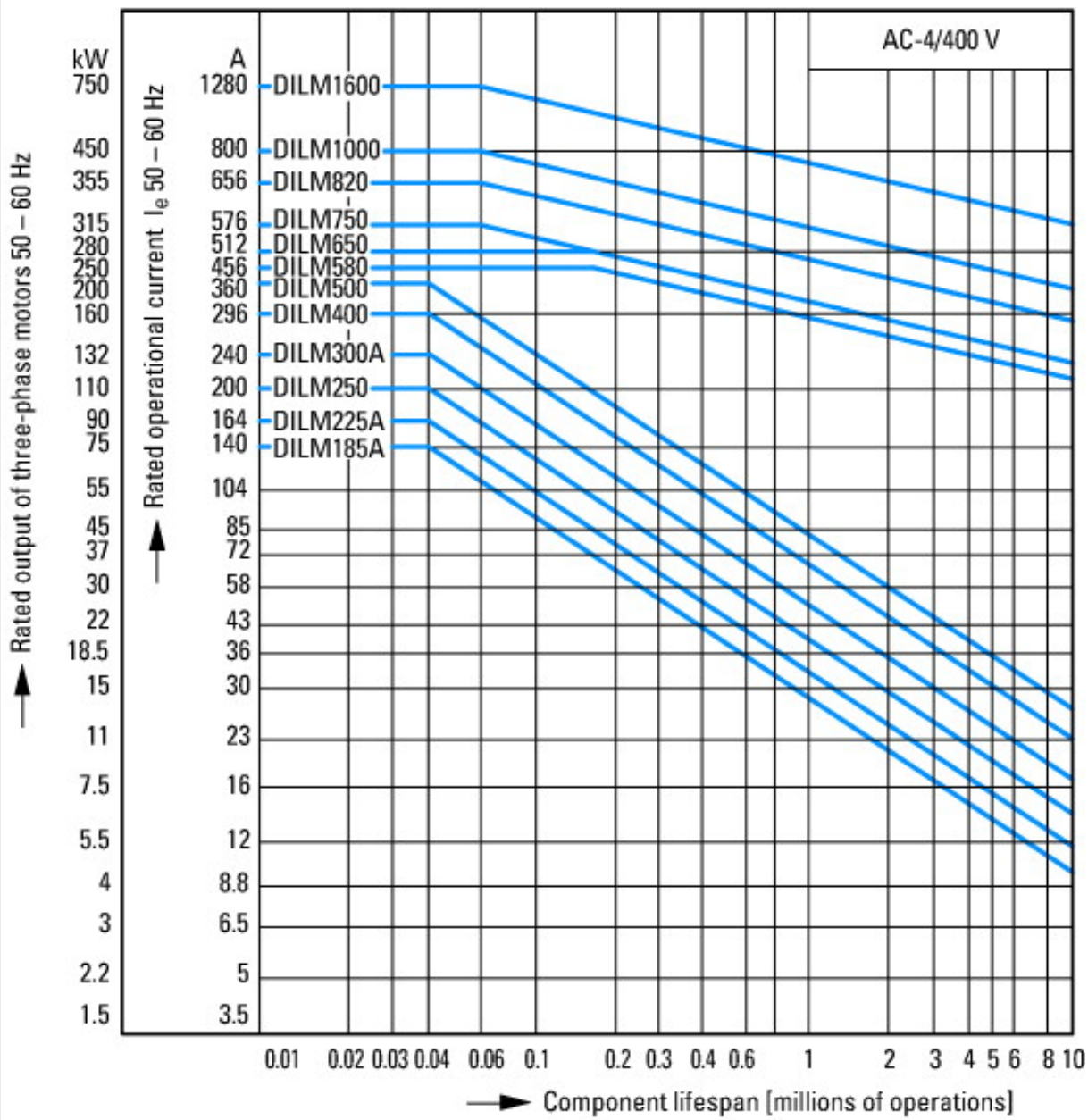

Extreme switching duty
 Squirrel-cage motor
 Operating characteristics
 Inching, plugging, reversing
 Electrical characteristics
 Make: up to 6 x rated motor current
 Break: up to 6 x rated motor current
 Utilization category
 100 % AC-4
 Typical applications
 Printing presses
 Wire-drawing machines
 Centrifuges
 Special drives for manufacturing and processing machines

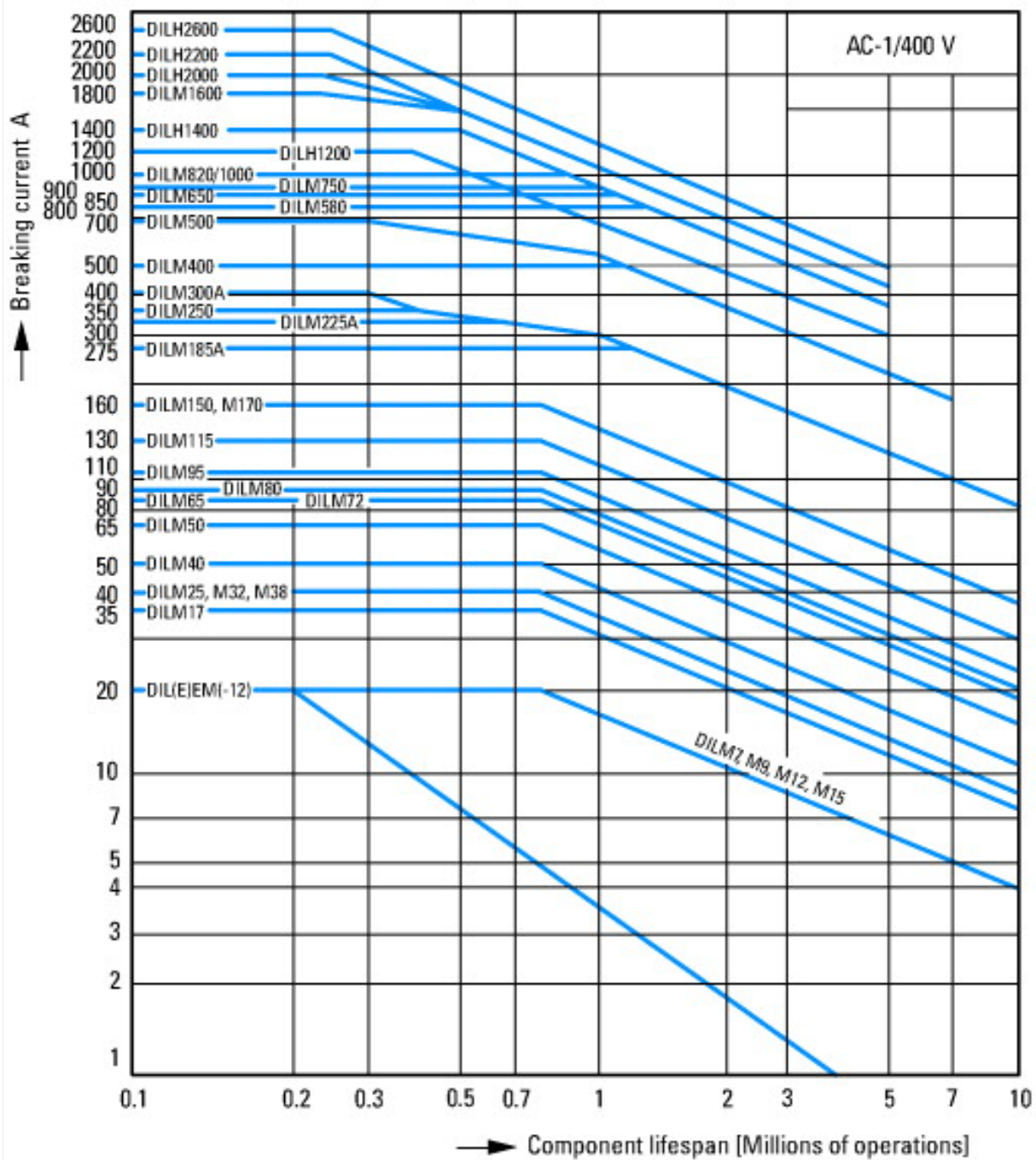

Switching conditions for 3 pole, non-motor loads
 Operating characteristics
 Non inductive and slightly inductive loads
 Electrical characteristics
 Switch on: 1 x rated operational current
 Switch off: 1 x rated operational current
 Utilization category
 100 % AC-1
 Typical examples of application
 Electric heat

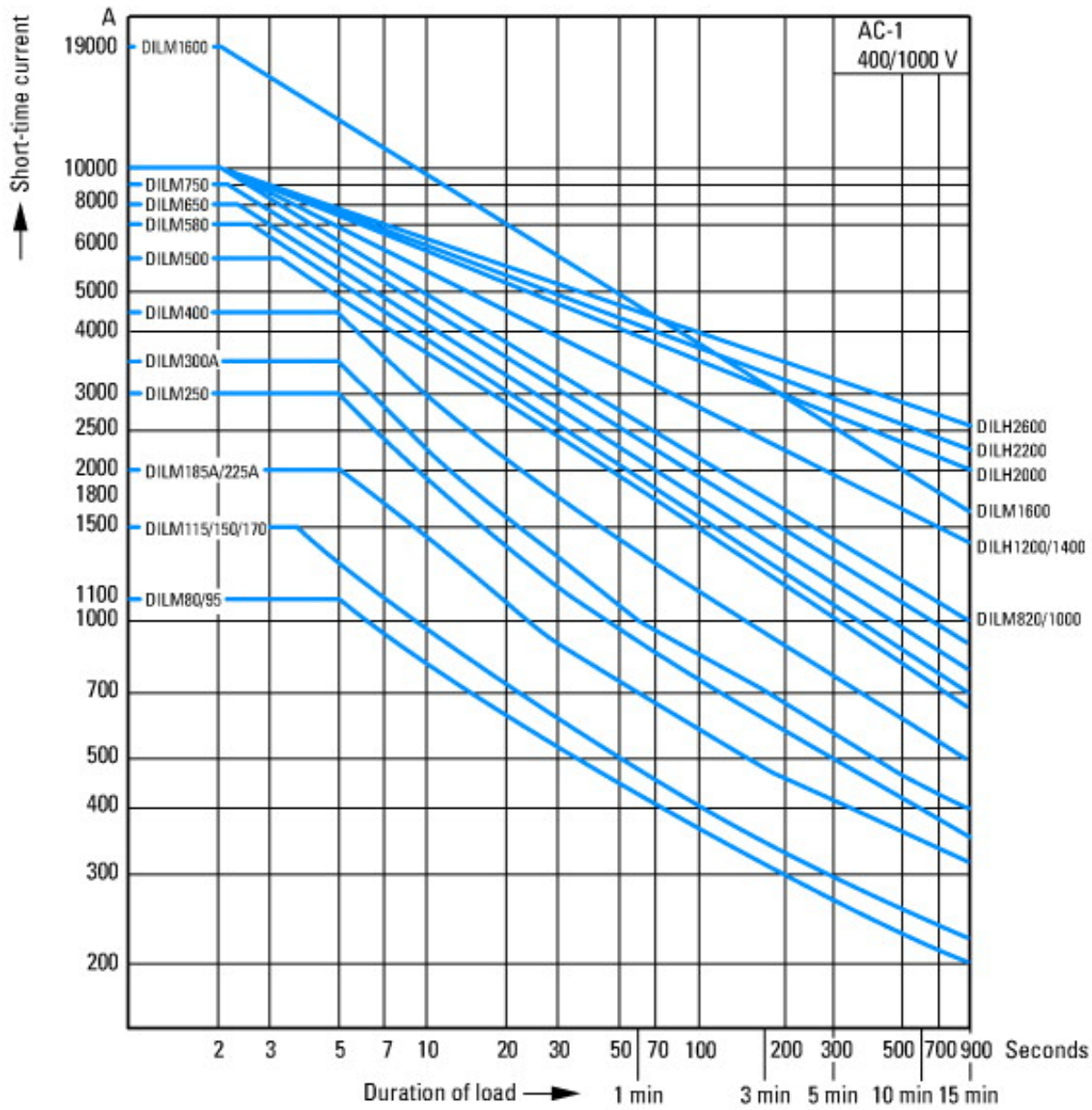

Short-time loading, 3-pole
 Time interval between two loading cycles: 15 minutes

Dimensions

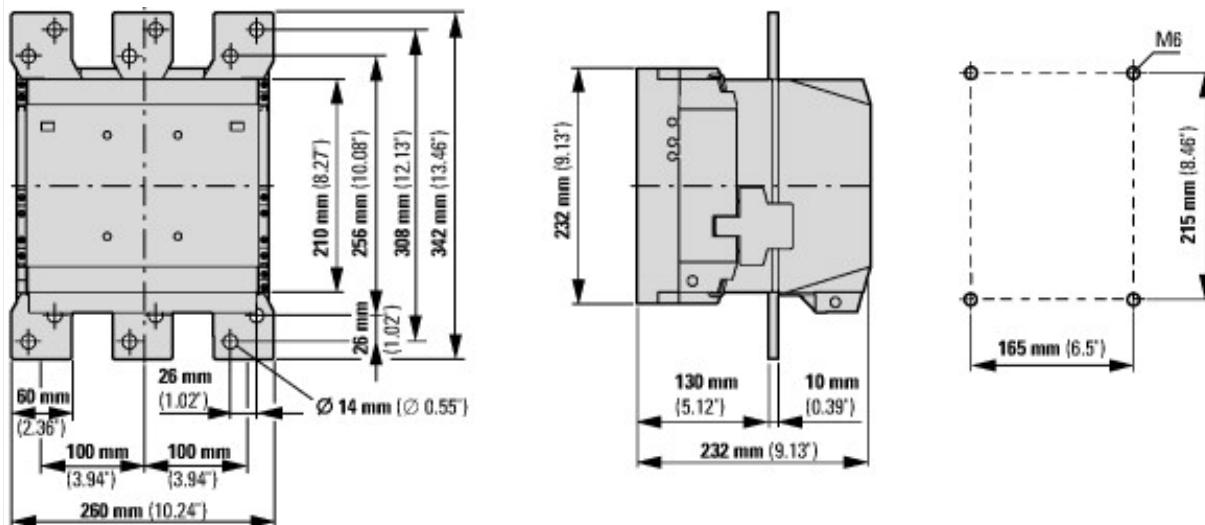

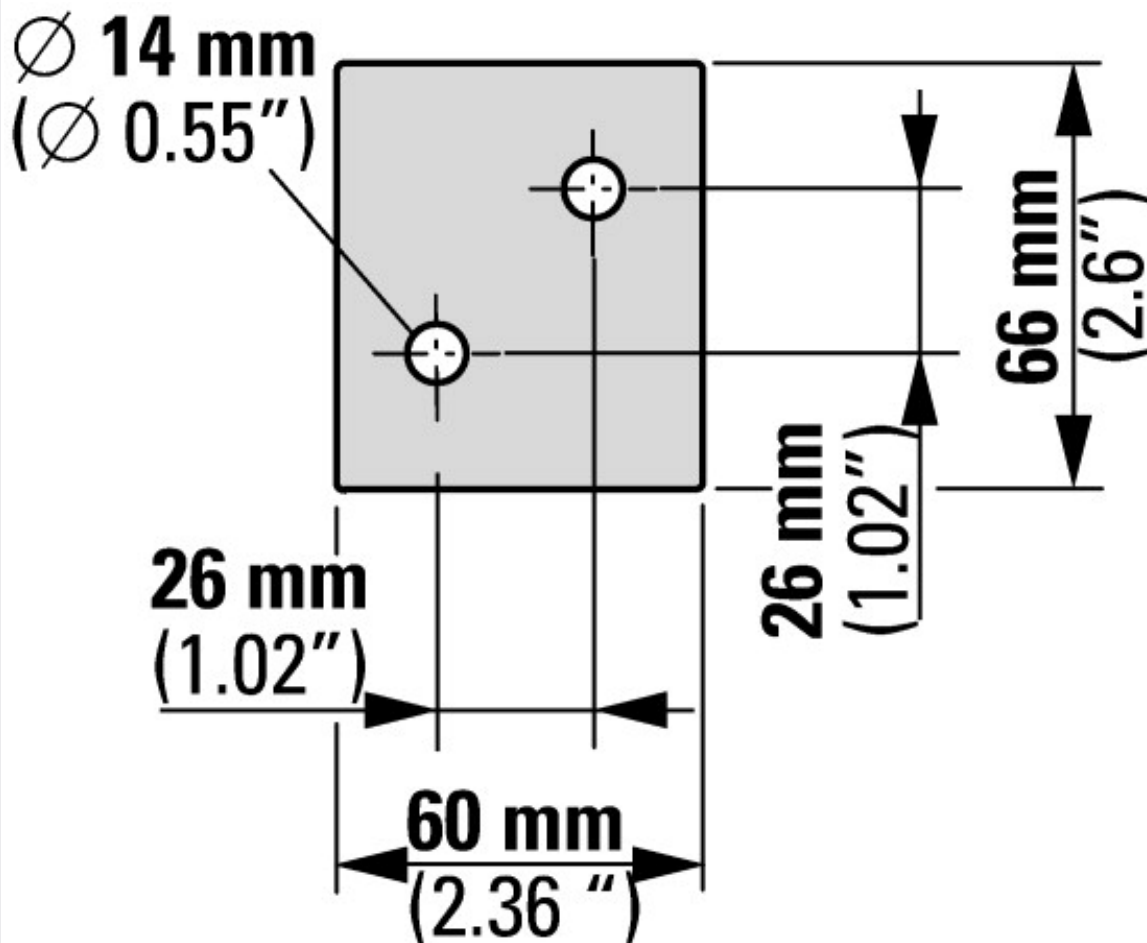

Additional product information (links)

IL034039ZU Contactors >170 A

IL034039ZU Contactors >170 A ftp://ftp.moeller.net/DOCUMENTATION/AWA_INSTRUCTIONS/IL034039ZU2016_10.pdf

Switchgear of Power Factor Correction Systems http://www.moeller.net/binary/ver_techpapers/ver934en.pdf

X-Start - Modern Switching Installations Efficiently Fitted and Wired Securely http://www.moeller.net/binary/ver_techpapers/ver938en.pdf

Mirror Contacts for Highly-Reliable Information Relating to Safety-Related Control Functions http://www.moeller.net/binary/ver_techpapers/ver944en.pdf

Effect of the Cable Capacitance of Long Control Cables on the Actuation of Contactors http://www.moeller.net/binary/ver_techpapers/ver949en.pdf

Motor starters and "Special Purpose Ratings" for the North American market http://www.moeller.net/binary/ver_techpapers/ver953en.pdf

Switchgear for Luminaires http://www.moeller.net/binary/ver_techpapers/ver955en.pdf

Standard Compliant and Functionally Safe Engineering Design with Mechanical Auxiliary Contacts http://www.moeller.net/binary/ver_techpapers/ver956en.pdf

The Interaction of Contactors with PLCs http://www.moeller.net/binary/ver_techpapers/ver957en.pdf

Busbar Component Adapters for modern Industrial control panels http://www.moeller.net/binary/ver_techpapers/ver960en.pdf