

Product	Contacts: 8, cable plug connector, cable outlet 6 - 8 mm
Area	Bayonet NCC Series 770
Article number	99 0771 002 08

Illustration

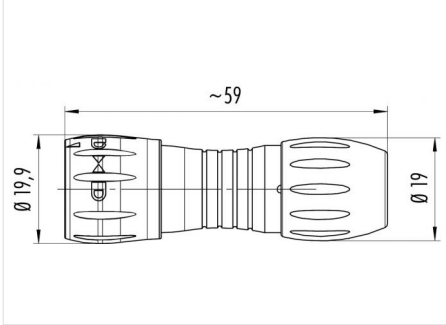

Scale drawing



Contact Arrangement

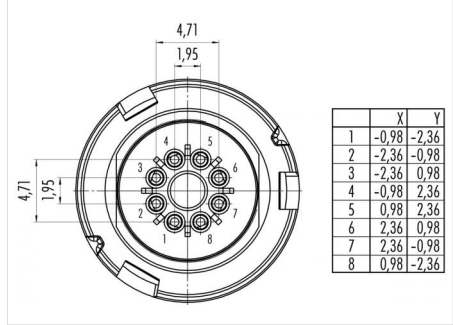

You can find the item description and assembly instruction on the next page.

Technical data

Common values

Connector Design	Cable plug connector
Connector locking system	Bayonet
Termination	Solder
Wire gauge (mm)	0.25 mm ²
Wire gauge (AWG)	max. 24
Cable outlet	6 - 8 mm
Upper temperature	85 °C
Lower temperature	-25 °C

Electrical values

Rated voltage	175 V
Rated impulse voltage	1750 V
Pollution degree	2
Overvoltage category	II
Material group	II
Rated current (40°C)	2 A
Volume resistivity	≤ 15 mΩ
EMV compliance	-
Degree of protection	IP67
Mechanical operation	> 5000 mating cycles

Material

Material of contact	CuZn (Brass)
Contact plating	Au (Gold)
Material of contact body	PA (UL 94 HB)
Material of housing	PA (UL 94 V-0)

Product **Contacts: 8, cable plug connector, cable outlet 6 - 8 mm**

Area **Bayonet NCC Series 770**
 Article number **99 0771 002 08**

Item description

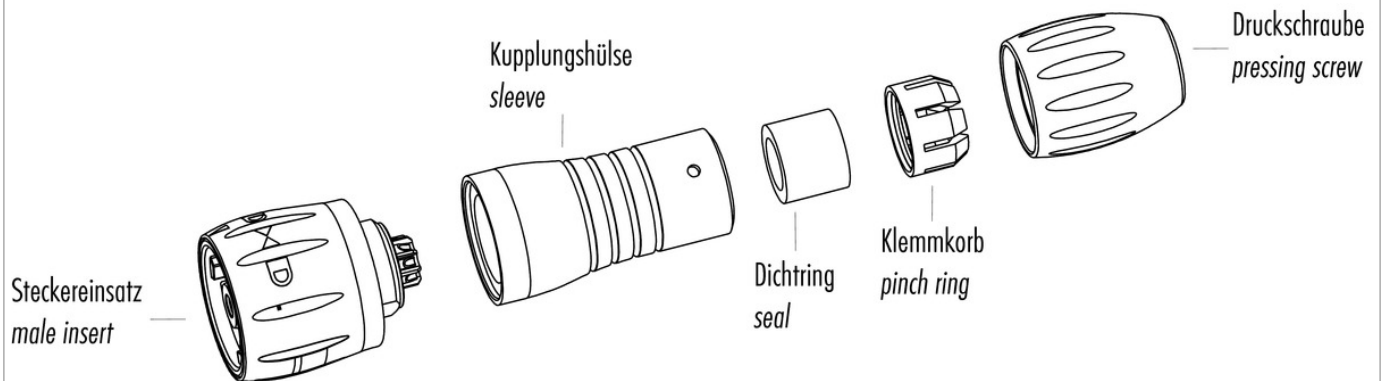

Installation instructions / Mounting cutout

1. Abmanteln auf L = 9mm. Ummantelung abstreifen.
2. Druckschraube, Klemmkorb, Dichtring und Abstandshülse auf Kabel auffädeln.
3. Litzen abisolieren (L = 3mm) und verzinnen.
4. Einsätze einlöten.
5. Bajonettdapter am Gewinde der Abstandshülse aufsetzen und mit leichtem Druck in Pfeilrichtung festschrauben.
6. Den Klemmkorb über den Dichtring bis auf Anschlag aufschieben.
7. Mit Druckschraube Klemm-, dichteinheit gegen Abstandshülse drücken und festschrauben.

1. Strip to 9mm length and take off the cable jacket.
2. Feed pressing screw, pinch ring, seal and distance sleeve to cable.
3. Strip the insulation off the wires (L = 3mm) and tin them.
4. Solder inserts.
5. Put bayonet adapter to the thread of the distance sleeve and screw it with slight pressure in the direction of the arrow.
6. Push pinch ring over sealing ring to block.
7. Push pressing screw together with clamp-sealing unit towards distance sleeve and screw tightly.

