

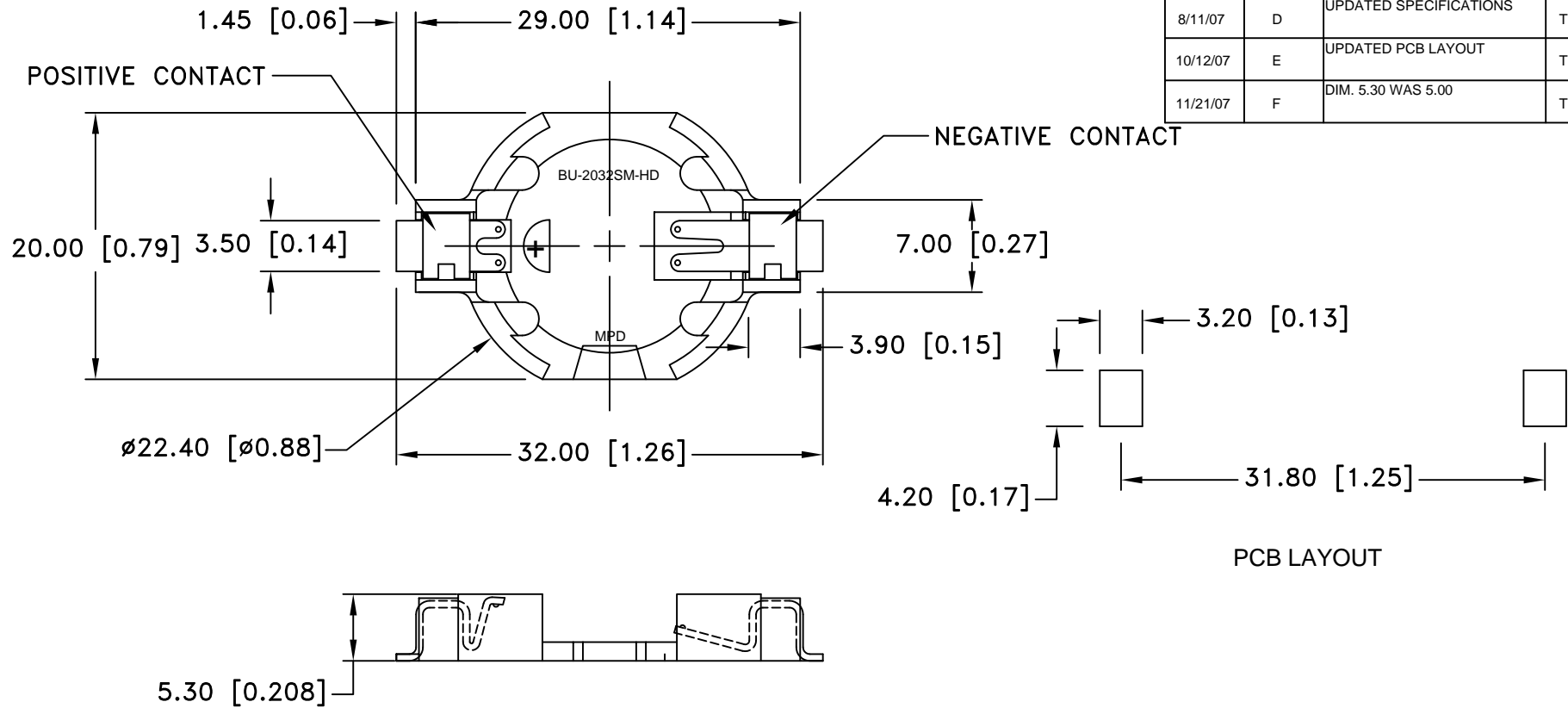

Date	SYM	REVISION RECORD	AUTH	DR.	CK.
12/18/04	A	ADDED SPECIFICATIONS	T.B.	B.S.	
04/16/05	B	ADDED COLOR PALE GOLDEN ROD - WAS WHITE	T.B.	B.S.	
10/22/05	C	ADDED "ROHS COMPLIANT"	T.B.	B.S.	
8/11/07	D	UPDATED SPECIFICATIONS	T.B.	B.S.	
10/12/07	E	UPDATED PCB LAYOUT	T.B.	B.S.	
11/21/07	F	DIM. 5.30 WAS 5.00	T.B.	B.S.	



SPECIFICATIONS:

- * Holder material- 30% glass reinforced Liquid Crystal Polymer resin, UL File No. E123598 UL94V-0
- * Color: White
- * Contacts : 0.020" thick PHOS-BRONZE, GOLD FLASH
- * Temperature range: -40°C to +315°C
- * Vibration Test: 10-50-10 Hz swept in 60 seconds
X,Y,Z direction: 1 hour each direction
- * Result: No dislodgement of the cell or damage
No discontinuity over 10 micro-seconds
- * Shock Test: Half sine wave acceleration 150G. 6 micro-seconds
3 shock pulses each direction per axis, total of 18 pulses
- * Result: No evidence of physical damage
- * ROHS COMPLIANT

Tolerance (Except as noted)	 Memory Protection Devices, Inc 200 Broad Hollow Road, Farmingdale, New York 11735	Scale	Drawn By B.S.
			Approved By T.B.
decimal ±.5 (.020)	Title SURFACE MOUNT BATTERY HOLDER FOR CR2032	Date 11/21/07	
Fractional ± .8 (.030)		Drawing Number BU2032SM-HD-G	
Angular ± 3°			