

GN 927.5 | Cam clamping levers

Stainless steel



- 1
- 2
- 3
- 4
- 5
- 6
- 7
- 8
- 9
- 10
- 11
- 12
- 13
- 14
- 15
- 16
- 17
- 18

LEVER BODY

Cast AISI CF-8 stainless steel, sandblasted matte finish.

ROTATING PIN

AISI 303 stainless steel.

CLAMPING ELEMENT

AISI 303 stainless steel with threaded hole or threaded screw.

STANDARD EXECUTIONS

- **GN 927.5-A**: positioning with AISI 303 stainless steel threaded adjustment wing nut, with AISI 303 stainless steel support bushing with glass fibre reinforced acetal-based technopolymer (POM) contact insert.
- **GN 927.5-B**: positioning without adjustment wing nut, with support bushing in glass-fibre reinforced polyamide based (PA) technopolymer.

FEATURES AND APPLICATIONS

GN 927.5 cam clamping levers are suitable for quick clamping. The GN 927.5-A version with adjustment wing nut provides quick and efficient tightening. In fact, the adjustment wing nut at the base enables adjustment of the tightening force used and simultaneous locking of the lever in the position required. This type of lever allows you to reach clamping forces up to 8 kN.



Way of clamping

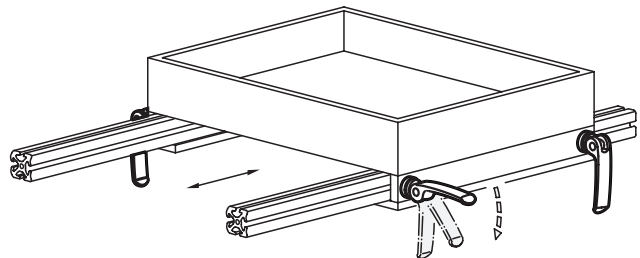
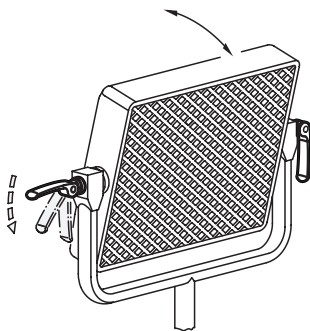
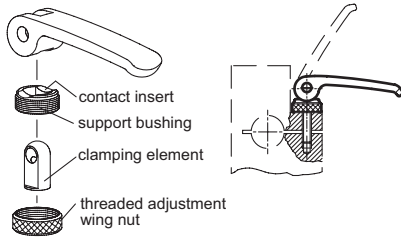

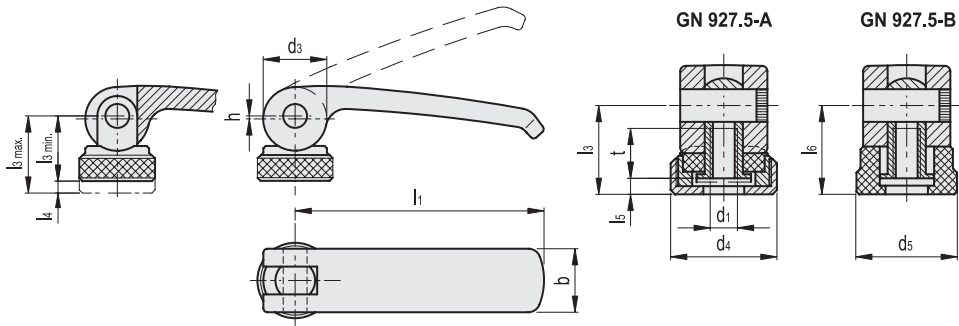

GN 927.5 (d1)

INOX STAINLESS STEEL

Code	Description	l1	d1	l3 min	l3 max	l4	l5	l6	h	d3	d4	d5	t	b	⚖
GN.35891	GN 927.5-44-M4-A	44	M4	13.2	15.2	2	2.2	-	0.5	12	15	-	8	12	28
GN.35911	GN 927.5-44-M5-A	44	M5	13.2	15.2	2	2.2	-	0.5	12	15	-	8	12	28
GN.35892	GN 927.5-44-M4-B	44	M4	-	-	2	2.2	15.2	0.5	12	-	14	8	12	25
GN.35912	GN 927.5-44-M5-B	44	M5	-	-	2	2.2	15.2	0.5	12	-	14	8	12	25
GN.69181	GN 927.5-63-M5-A	63	M5	16.3	18.8	2.5	3	-	0.75	16	19	-	10	16	57
GN.69183	GN 927.5-63-M6-A	63	M6	16.3	18.8	2.5	3	-	0.75	16	19	-	10	16	58
GN.69182	GN 927.5-63-M5-B	63	M5	-	-	2.5	3	16.3	0.75	16	-	18.5	10	16	57
GN.69184	GN 927.5-63-M6-B	63	M6	-	-	2.5	3	16.3	0.75	16	-	18.5	10	16	60
GN.69221	GN 927.5-82-M6-A	82	M6	19.5	22.5	3	3.7	-	1	20	25	-	12	20	60
GN.69223	GN 927.5-82-M8-A	82	M8	19.5	22.5	3	3.7	-	1	20	25	-	12	20	100
GN.69222	GN 927.5-82-M6-B	82	M6	-	-	3	3.7	19.5	1	20	-	22.5	12	20	60
GN.69224	GN 927.5-82-M8-B	82	M8	-	-	3	3.7	19.5	1	20	-	22.5	12	20	98
GN.69261	GN 927.5-101-M8-A	101	M8	25.3	29.3	4	4.8	-	1.5	26	30	-	15	25	216
GN.69263	GN 927.5-101-M10-A	101	M10	25.3	29.3	4	4.8	-	1.5	26	30	-	15	25	211
GN.69262	GN 927.5-101-M8-B	101	M8	-	-	4	4.8	25.3	1.5	26	-	27	15	25	200
GN.69264	GN 927.5-101-M10-B	101	M10	-	-	4	4.8	25.3	1.5	26	-	27	15	25	200

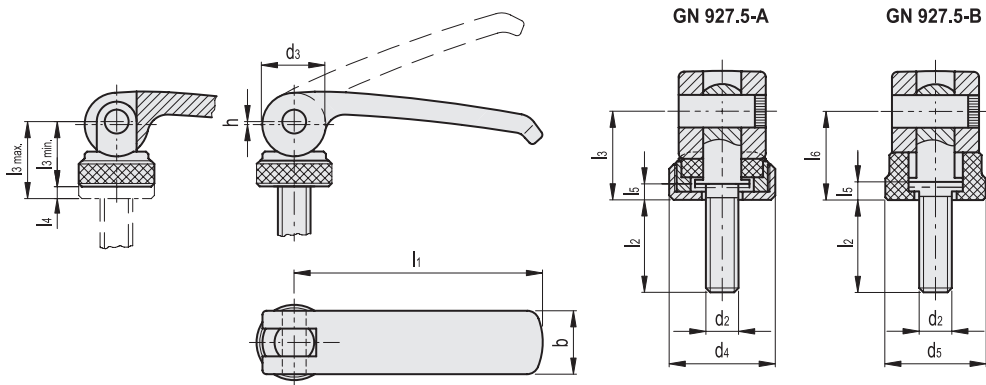

GN 927.5 (d2 - l2)

INOX STAINLESS STEEL

Code	Description	l1	d2	l2	l3 min	l3 max	l4	l5	l6	h	d3	d4	d5	b	⚖
GN.35896	GN 927.5-44-M4-12-A	44	M4	12	13.2	15.2	2	2.2	-	0.5	12	15	-	12	30
GN.35897	GN 927.5-44-M4-16-A	44	M4	16	13.2	15.2	2	2.2	-	0.5	12	15	-	12	30
GN.35898	GN 927.5-44-M4-20-A	44	M4	20	13.2	15.2	2	2.2	-	0.5	12	15	-	12	29
GN.35899	GN 927.5-44-M4-25-A	44	M4	25	13.2	15.2	2	2.2	-	0.5	12	15	-	12	31
GN.35900	GN 927.5-44-M4-30-A	44	M4	30	13.2	15.2	2	2.2	-	0.5	12	15	-	12	31
GN.35916	GN 927.5-44-M5-12-A	44	M5	12	13.2	15.2	2	2.2	-	0.5	12	15	-	12	29
GN.35917	GN 927.5-44-M5-16-A	44	M5	16	13.2	15.2	2	2.2	-	0.5	12	15	-	12	31
GN.35918	GN 927.5-44-M5-20-A	44	M5	20	13.2	15.2	2	2.2	-	0.5	12	15	-	12	33
GN.35919	GN 927.5-44-M5-25-A	44	M5	25	13.2	15.2	2	2.2	-	0.5	12	15	-	12	33
GN.35920	GN 927.5-44-M5-30-A	44	M5	30	13.2	15.2	2	2.2	-	0.5	12	15	-	12	33
GN.35921	GN 927.5-44-M5-35-A	44	M5	35	13.2	15.2	2	2.2	-	0.5	12	15	-	12	35
GN.35922	GN 927.5-44-M5-40-A	44	M5	40	13.2	15.2	2	2.2	-	0.5	12	15	-	12	33



- 1
- 2
- 3
- 4
- 5
- 6
- 7
- 8
- 9
- 10
- 11
- 12
- 13
- 14
- 15
- 16
- 17
- 18

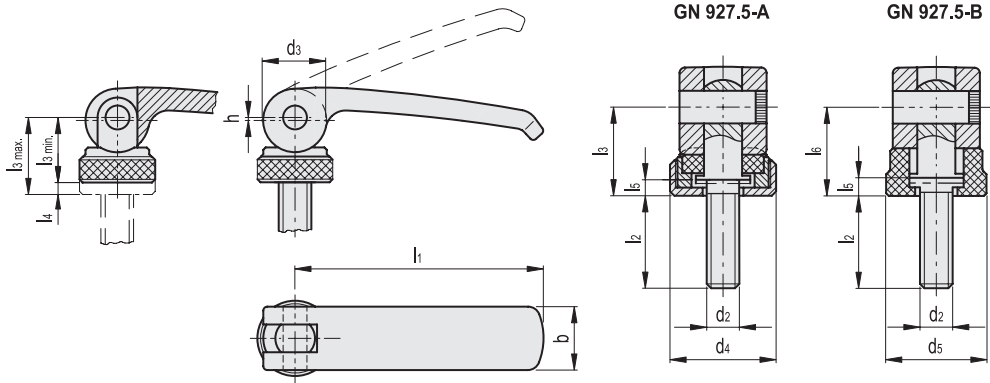

GN 927.5 (d2 - l2)

Code	Description	l1	d2	l2	l3 min	l3 max	l4	l5	l6	h	d3	d4	d5	b	△
GN.35926	GN 927.5-63-M5-16-A	63	M5	16	16.3	18.8	2.5	3	-	0.75	16	19	-	16	67
GN.69191	GN 927.5-63-M5-20-A	63	M5	20	16.3	18.8	2.5	3	-	0.75	16	19	-	16	55
GN.69193	GN 927.5-63-M5-25-A	63	M5	25	16.3	18.8	2.5	3	-	0.75	16	19	-	16	56
GN.69195	GN 927.5-63-M5-30-A	63	M5	30	16.3	18.8	2.5	3	-	0.75	16	19	-	16	62
GN.69197	GN 927.5-63-M5-35-A	63	M5	35	16.3	18.8	2.5	3	-	0.75	16	19	-	16	62
GN.69199	GN 927.5-63-M5-40-A	63	M5	40	16.3	18.8	2.5	3	-	0.75	16	19	-	16	63
GN.69201	GN 927.5-63-M5-50-A	63	M5	50	16.3	18.8	2.5	3	-	0.75	16	19	-	16	65
GN.35930	GN 927.5-63-M6-16-A	63	M6	16	16.3	18.8	2.5	3	-	0.75	16	19	-	16	67
GN.69203	GN 927.5-63-M6-20-A	63	M6	20	16.3	18.8	2.5	3	-	0.75	16	19	-	16	62
GN.69205	GN 927.5-63-M6-25-A	63	M6	25	16.3	18.8	2.5	3	-	0.75	16	19	-	16	63
GN.69207	GN 927.5-63-M6-30-A	63	M6	30	16.3	18.8	2.5	3	-	0.75	16	19	-	16	63
GN.69209	GN 927.5-63-M6-35-A	63	M6	35	16.3	18.8	2.5	3	-	0.75	16	19	-	16	64
GN.69211	GN 927.5-63-M6-40-A	63	M6	40	16.3	18.8	2.5	3	-	0.75	16	19	-	16	65
GN.69213	GN 927.5-63-M6-50-A	63	M6	50	16.3	18.8	2.5	3	-	0.75	16	19	-	16	68
GN.35928	GN 927.5-63-M5-16-B	63	M5	16	-	-	2.5	3	16.3	0.75	16	-	18.5	16	60
GN.69192	GN 927.5-63-M5-20-B	63	M5	20	-	-	2.5	3	16.3	0.75	16	-	18.5	16	55
GN.69194	GN 927.5-63-M5-25-B	63	M5	25	-	-	2.5	3	16.3	0.75	16	-	18.5	16	56
GN.69196	GN 927.5-63-M5-30-B	63	M5	30	-	-	2.5	3	16.3	0.75	16	-	18.5	16	60
GN.69198	GN 927.5-63-M5-35-B	63	M5	35	-	-	2.5	3	16.3	0.75	16	-	18.5	16	62
GN.69200	GN 927.5-63-M5-40-B	63	M5	40	-	-	2.5	3	16.3	0.75	16	-	18.5	16	63
GN.69202	GN 927.5-63-M5-50-B	63	M5	50	-	-	2.5	3	16.3	0.75	16	-	18.5	16	65
GN.35932	GN 927.5-63-M6-16-B	63	M6	16	-	-	2.5	3	16.3	0.75	16	-	18.5	16	60
GN.69204	GN 927.5-63-M6-20-B	63	M6	20	-	-	2.5	3	16.3	0.75	16	-	18.5	16	62
GN.69206	GN 927.5-63-M6-25-B	63	M6	25	-	-	2.5	3	16.3	0.75	16	-	18.5	16	63
GN.69208	GN 927.5-63-M6-30-B	63	M6	30	-	-	2.5	3	16.3	0.75	16	-	18.5	16	63
GN.69210	GN 927.5-63-M6-35-B	63	M6	35	-	-	2.5	3	16.3	0.75	16	-	18.5	16	64
GN.69212	GN 927.5-63-M6-40-B	63	M6	40	-	-	2.5	3	16.3	0.75	16	-	18.5	16	65
GN.69214	GN 927.5-63-M6-50-B	63	M6	50	-	-	2.5	3	16.3	0.75	16	-	18.5	16	68

Clamping handles

GN 927.5 (d2 - l2)

INOX STAINLESS STEEL

Code	Description	l1	d2	l2	l3 min	l3 max	l4	l5	l6	h	d3	d4	d5	b	
GN.35936	GN 927.5-82-M6-20-A	82	M6	20	19.5	22.5	3	3.7	-	1	20	25	-	20	131
GN.69231	GN 927.5-82-M6-25-A	82	M6	25	19.5	22.5	3	3.7	-	1	20	25	-	20	120
GN.69233	GN 927.5-82-M6-30-A	82	M6	30	19.5	22.5	3	3.7	-	1	20	25	-	20	120
GN.69235	GN 927.5-82-M6-35-A	82	M6	35	19.5	22.5	3	3.7	-	1	20	25	-	20	120
GN.69237	GN 927.5-82-M6-40-A	82	M6	40	19.5	22.5	3	3.7	-	1	20	25	-	20	120
GN.69239	GN 927.5-82-M6-50-A	82	M6	50	19.5	22.5	3	3.7	-	1	20	25	-	20	122
GN.69241	GN 927.5-82-M6-60-A	82	M6	60	19.5	22.5	3	3.7	-	1	20	25	-	20	122
GN.35940	GN 927.5-82-M8-20-A	82	M8	20	19.5	22.5	3	3.7	-	1	20	25	-	20	121
GN.69243	GN 927.5-82-M8-25-A	82	M8	25	19.5	22.5	3	3.7	-	1	20	25	-	20	122
GN.69245	GN 927.5-82-M8-30-A	82	M8	30	19.5	22.5	3	3.7	-	1	20	25	-	20	123
GN.69247	GN 927.5-82-M8-35-A	82	M8	35	19.5	22.5	3	3.7	-	1	20	25	-	20	125
GN.69249	GN 927.5-82-M8-40-A	82	M8	40	19.5	22.5	3	3.7	-	1	20	25	-	20	129
GN.69251	GN 927.5-82-M8-50-A	82	M8	50	19.5	22.5	3	3.7	-	1	20	25	-	20	130
GN.69253	GN 927.5-82-M8-60-A	82	M8	60	19.5	22.5	3	3.7	-	1	20	25	-	20	132
GN.35938	GN 927.5-82-M6-20-B	82	M6	20	-	-	3	3.7	19.5	1	20	-	22.5	20	118
GN.69232	GN 927.5-82-M6-25-B	82	M6	25	-	-	3	3.7	19.5	1	20	-	22.5	20	120
GN.69234	GN 927.5-82-M6-30-B	82	M6	30	-	-	3	3.7	19.5	1	20	-	22.5	20	120
GN.69236	GN 927.5-82-M6-35-B	82	M6	35	-	-	3	3.7	19.5	1	20	-	22.5	20	120
GN.69238	GN 927.5-82-M6-40-B	82	M6	40	-	-	3	3.7	19.5	1	20	-	22.5	20	120
GN.69240	GN 927.5-82-M6-50-B	82	M6	50	-	-	3	3.7	19.5	1	20	-	22.5	20	122
GN.69242	GN 927.5-82-M6-60-B	82	M6	60	-	-	3	3.7	19.5	1	20	-	22.5	20	122
GN.35942	GN 927.5-82-M8-20-B	82	M8	20	-	-	3	3.7	19.5	1	20	-	22.5	20	121
GN.69244	GN 927.5-82-M8-25-B	82	M8	25	-	-	3	3.7	19.5	1	20	-	22.5	20	122
GN.69246	GN 927.5-82-M8-30-B	82	M8	30	-	-	3	3.7	19.5	1	20	-	22.5	20	123
GN.69248	GN 927.5-82-M8-35-B	82	M8	35	-	-	3	3.7	19.5	1	20	-	22.5	20	125
GN.69250	GN 927.5-82-M8-40-B	82	M8	40	-	-	3	3.7	19.5	1	20	-	22.5	20	129
GN.69252	GN 927.5-82-M8-50-B	82	M8	50	-	-	3	3.7	19.5	1	20	-	22.5	20	130
GN.69254	GN 927.5-82-M8-60-B	82	M8	60	-	-	3	3.7	19.5	1	20	-	22.5	20	132
GN.69271	GN 927.5-101-M8-20-A	101	M8	20	25.3	29.3	4	4.8	-	1.5	26	30	-	25	224
GN.35946	GN 927.5-101-M8-25-A	101	M8	25	25.3	29.3	4	4.8	-	1.5	26	30	-	25	256
GN.69273	GN 927.5-101-M8-30-A	101	M8	30	25.3	29.3	4	4.8	-	1.5	26	30	-	25	227
GN.35950	GN 927.5-101-M8-35-A	101	M8	35	25.3	29.3	4	4.8	-	1.5	26	30	-	25	200
GN.69275	GN 927.5-101-M8-40-A	101	M8	40	25.3	29.3	4	4.8	-	1.5	26	30	-	25	232
GN.69277	GN 927.5-101-M8-50-A	101	M8	50	25.3	29.3	4	4.8	-	1.5	26	30	-	25	235
GN.69279	GN 927.5-101-M8-60-A	101	M8	60	25.3	29.3	4	4.8	-	1.5	26	30	-	25	238
GN.69281	GN 927.5-101-M10-20-A	101	M10	20	25.3	29.3	4	4.8	-	1.5	26	30	-	25	229
GN.35954	GN 927.5-101-M10-25-A	101	M10	25	25.3	29.3	4	4.8	-	1.5	26	30	-	25	260
GN.69283	GN 927.5-101-M10-30-A	101	M10	30	25.3	29.3	4	4.8	-	1.5	26	30	-	25	234
GN.35958	GN 927.5-101-M10-35-A	101	M10	35	25.3	29.3	4	4.8	-	1.5	26	30	-	25	264
GN.69285	GN 927.5-101-M10-40-A	101	M10	40	25.3	29.3	4	4.8	-	1.5	26	30	-	25	240
GN.69287	GN 927.5-101-M10-50-A	101	M10	50	25.3	29.3	4	4.8	-	1.5	26	30	-	25	260
GN.69289	GN 927.5-101-M10-60-A	101	M10	60	25.3	29.3	4	4.8	-	1.5	26	30	-	25	265
GN.69272	GN 927.5-101-M8-20-B	101	M8	20	-	-	4	4.8	25.3	1.5	26	-	27	25	224
GN.35948	GN 927.5-101-M8-25-B	101	M8	25	-	-	4	4.8	25.3	1.5	26	-	27	25	229
GN.69274	GN 927.5-101-M8-30-B	101	M8	30	-	-	4	4.8	25.3	1.5	26	-	27	25	227
GN.35952	GN 927.5-101-M8-35-B	101	M8	35	-	-	4	4.8	25.3	1.5	26	-	27	25	234
GN.69276	GN 927.5-101-M8-40-B	101	M8	40	-	-	4	4.8	25.3	1.5	26	-	27	25	232
GN.69278	GN 927.5-101-M8-50-B	101	M8	50	-	-	4	4.8	25.3	1.5	26	-	27	25	235
GN.69280	GN 927.5-101-M8-60-B	101	M8	60	-	-	4	4.8	25.3	1.5	26	-	27	25	238
GN.69282	GN 927.5-101-M10-20-B	101	M10	20	-	-	4	4.8	25.3	1.5	26	-	27	25	229
GN.35956	GN 927.5-101-M10-25-B	101	M10	25	-	-	4	4.8	25.3	1.5	26	-	27	25	235
GN.69284	GN 927.5-101-M10-30-B	101	M10	30	-	-	4	4.8	25.3	1.5	26	-	27	25	234
GN.35960	GN 927.5-101-M10-35-B	101	M10	35	-	-	4	4.8	25.3	1.5	26	-	27	25	240
GN.69286	GN 927.5-101-M10-40-B	101	M10	40	-	-	4	4.8	25.3	1.5	26	-	27	25	240
GN.69288	GN 927.5-101-M10-50-B	101	M10	50	-	-	4	4.8	25.3	1.5	26	-	27	25	260
GN.69290	GN 927.5-101-M10-60-B	101	M10	60	-	-	4	4.8	25.3	1.5	26	-	27	25	265



Clamping handles