

Locking Assemblies COM-AS

Material: Steel.

- For fixing a hub (e.g. V-belt pulley or similar) on a shaft.
- For medium high torques. Like COM-A, but with slotted rings.
- Not self-centering.
- Self-releasing at dismounting.
- No axial movement during mounting.

Ordering Details: e.g.: Product No. 615 300 14, Locking Assembly COM-AS, 14 mm

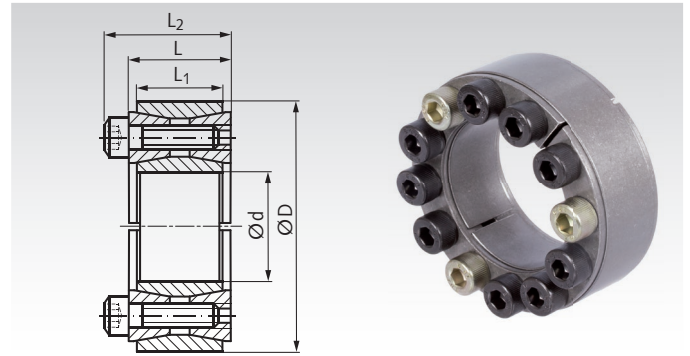

Product No.	d mm	D mm	L mm	L ₁ mm	L ₂ mm	T Nm	F _{ax} kN	P _w N/mm ²	P _N N/mm ²	Screw 12.9 Number x Size	T _A Nm	Weight kg
615 300 14	14	42	20	17	26	190	27	300	101	8 x M6	15	0,18
615 300 15	15	42	20	17	26	210	28	291	103	8 x M6	15	0,18
615 300 16	16	44	20	17	26	215	26	259	102	8 x M6	15	0,18
615 300 17	17	44	20	17	26	230	27	247	95	8 x M6	15	0,18
615 300 18	18	47	20	17	26	250	26	200	85	8 x M6	15	0,22
615 300 19	19	47	20	17	26	320	33	225	98	8 x M6	15	0,22
615 300 20	20	47	20	17	26	340	33	237	103	8 x M6	15	0,21
615 300 22	22	47	20	17	26	340	35	204	95	8 x M6	15	0,21
615 300 24	24	50	20	17	26	450	38	220	108	8 x M6	15	0,23
615 300 25	25	50	20	17	26	470	39	204	105	8 x M6	15	0,23
615 300 28	28	55	20	17	26	610	42	212	109	10 x M6	15	0,27
615 300 30	30	55	20	17	26	610	44	187	104	10 x M6	15	0,26
615 300 32	32	60	20	17	26	810	51	213	118	12 x M6	15	0,30
615 300 35	35	60	20	17	26	910	52	200	119	12 x M6	15	0,30
615 300 38	38	65	20	17	26	1110	58	206	122	14 x M6	15	0,35
615 300 40	40	65	20	17	26	1160	58	194	121	14 x M6	15	0,32
615 300 42	42	75	24	20	32	1840	87	238	135	12 x M8	37	0,57
615 300 45	45	75	24	20	32	2000	87	220	133	12 x M8	37	0,55
615 300 48	48	80	24	20	32	2200	87	218	128	12 x M8	37	0,60
615 300 50	50	80	24	20	32	2200	89	200	124	12 x M8	37	0,56
615 300 55	55	85	24	20	32	2900	105	222	147	14 x M8	37	0,65
615 300 60	60	90	24	20	32	3100	109	196	132	14 x M8	37	0,66
615 300 65	65	95	24	20	32	3800	117	206	143	16 x M8	37	0,72
615 300 70	70	110	28	24	38	5500	146	222	142	14 x M10	70	1,27
615 300 75	75	115	28	24	38	5700	159	189	125	14 x M10	70	1,33
615 300 80	80	120	28	24	38	6400	162	189	130	14 x M10	70	1,35
615 300 85	85	125	28	24	38	7400	172	199	137	16 x M10	70	1,45
615 300 90	90	130	28	24	38	7700	175	182	130	16 x M10	70	1,55
615 300 95	95	135	28	24	38	9200	195	197	141	18 x M10	70	1,65
615 301 00	100	145	33	26	45	11300	221	199	142	14 x M12	127	2,20

More sizes up to d=1,000mm for 2,336,000Nm are available.

Price and delivery time on request.

T = transmittable torque at $F_{ax} = 0$.

F_{ax} = transmittable axial force at $T = 0$.

P_w = surface pressure onto the shaft.

P_N = surface pressure onto the hub.

T_A = fastening torque of the screws.

Fit

Shaft h8, Hub H8.

Surface roughness R_z max. 12.5 μm .

Mounting

Slightly oil the locking assembly before mounting, do not use molybdenum disulphide or grease. Tighten the screws evenly and crosswise in several steps.

Demounting

Due to the cone angle, the locking assembly is usually released once all screws have been fully unfastened. There are three large auxiliary threads cut into the front ring, which serve to remove this ring.