

- 1
- 2
- 3
- 4
- 5
- 6
- 7
- 8
- 9
- 10
- 11
- 12
- 13
- 14
- 15
- 16
- 17
- 18



STANDARD EXECUTIONS

Threaded pass-through hole.

- **GN 206:** cast iron, smooth finish, paintable.
- **GN 206-NI:** stainless steel fine-casting, sandblasted matte finish.

MATERIAL

Cast stainless steel, sandblasted matte finish.

STANDARD EXECUTION

Threaded pass-through hole.

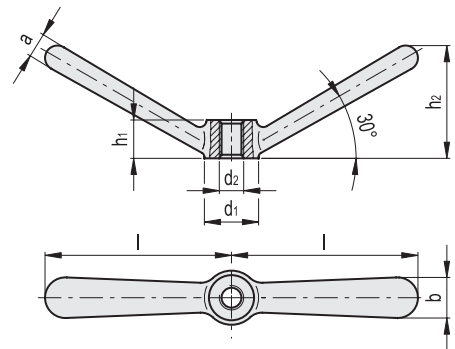
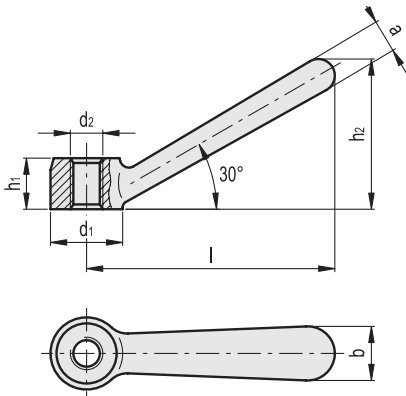

GN 206

Code	Description	d1	d2	l	h1	h2	a	b	△
GN.21101	GN 206-16-M8	16	M8	56	12	34	7	12	38
GN.21111	GN 206-20-M10	20	M10	70	14	42.5	9	14	57
GN.21121	GN 206-25-M12	25	M12	87	18	53	11	18	128
GN.21131	GN 206-32-M16	32	M16	109	22	66.5	15	22	257
GN.21141	GN 206-40-M20	40	M20	140	28	84.5	18	28	518

GN 206-NI

Code	Description	d1	d2	l	h1	h2	a	b	△
GN.21102	GN 206-16-M8-NI	16	M8	56	12	34	7	12	30
GN.21112	GN 206-20-M10-NI	20	M10	70	14	42.5	9	14	60
GN.21122	GN 206-25-M12-NI	25	M12	87	18	53	11	18	125
GN.21132	GN 206-32-M16-NI	32	M16	109	22	66.5	15	22	248
GN.21142	GN 206-40-M20-NI	40	M20	140	28	84.5	18	28	518



Code	Description	d1	d2	l	h1	h2	a	b	△
GN.21202	GN 206.1-16-M8-NI	16	M8	56	12	34	7	12	53
GN.21212	GN 206.1-20-M10-NI	20	M10	70	14	42	9	14	98
GN.21222	GN 206.1-25-M12-NI	25	M12	87	18	53	11	18	200
GN.21232	GN 206.1-32-M16-NI	32	M16	109	22	66	15	22	396
GN.21242	GN 206.1-40-M20-NI	40	M20	140	28	84	18	28	720