

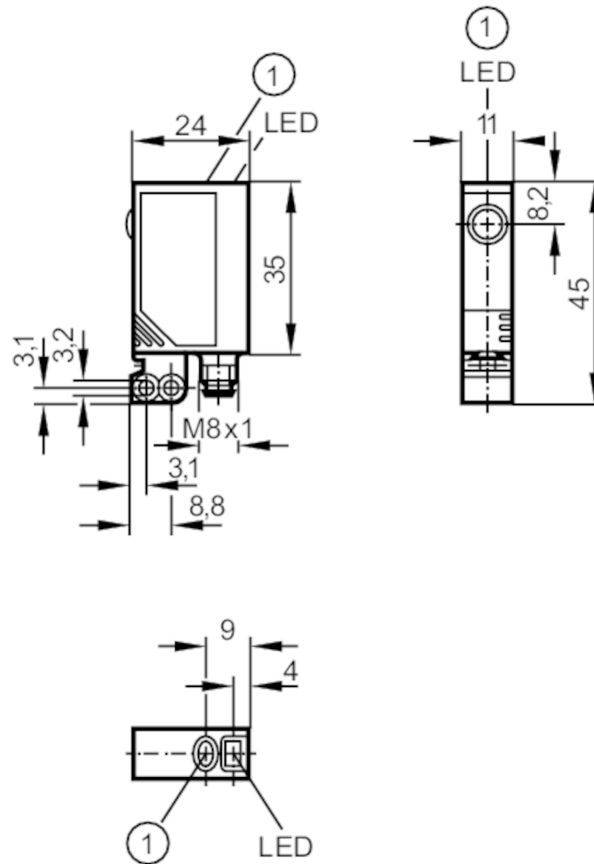

## Through-beam laser sensor receiver

OJELFPKG/SO/AS



1 pushbutton



### Product characteristics

Type of light	red light
Laser protection class	1
Housing	rectangular
Dimensions [mm]	35 x 11 x 24

### Application

Function principle	Through-beam sensor
--------------------	---------------------

### Electrical data

Operating voltage [V]	10...30 DC
Current consumption [mA]	< 12
Protection class	III
Reverse polarity protection	yes
Type of light	red light
Wave length [nm]	650
Typ. lifetime [h]	50000



## Through-beam laser sensor receiver

OJELFPKG/SO/AS

Outputs		
Electrical design		PNP
Output function		light-on/dark-on mode; (programmable)
Max. voltage drop switching output DC	[V]	2.5
Permanent current rating of switching output DC	[mA]	200
Switching frequency DC	[Hz]	1200
Short-circuit protection		yes
Type of short-circuit protection		pulsed
Overload protection		yes
Detection zone		
Transmitter / receiver		receiver
Range	[m]	< 15
Range adjustable		yes
Diameter of the smallest detectable object	[mm]	2
Operating conditions		
Ambient temperature	[°C]	-10...60
Protection		IP 67
Tests / approvals		
EMC		EN 60947-5-2
Laser protection class		1
Notes on laser protection	Caution:	laser light
	laser class:	1
		EN / IEC60825-1:2007
		EN / IEC60825-1:2014
		Complies with 21 CFR 1040 except for deviations pursuant to Laser Notice No. 50, dated June 2007.
MTTF	[years]	952
Mechanical data		
Weight	[g]	42
Housing		rectangular
Dimensions	[mm]	35 x 11 x 24
Materials		housing: ABS; fixture: diecast zinc; LED window: SEPS; pushbutton: SEPS
Lens material		glass
Lens alignment		side lens
Displays / operating elements		
Display	switching status	1 x LED, yellow
	operation	1 x LED, green
	function	1 x LED, red
Electronic lock		yes



## Through-beam laser sensor receiver

OJELFPKG/SO/AS

Accessories	
Accessories (supplied)	Basic clip: 1 x, E20964
	screws: 2 x x M3 x 16
	spring washers: 2 x
	Nuts: 2 x

Remarks	
Remarks	operating voltage "supply class 2" according to cULus
Pack quantity	1 pcs.

### Electrical connection

Connector: 1 x M8



### Connection

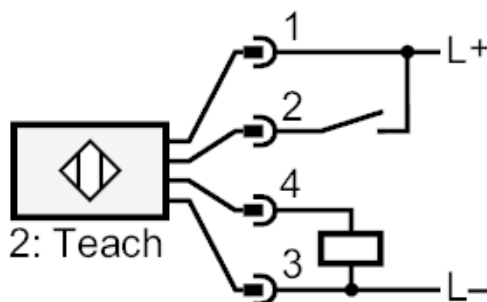

2 Teach

# OJ5039



## Through-beam laser sensor receiver

OJELFPKG/SO/AS

### Diagrams and graphs

excess gain graph

