

**PHYSICAL DIMENSIONS:**

A	4.50 [ .177 ]	± 0.25 [ .010 ]
B	3.20 [ .126 ]	± 0.25 [ .010 ]
C	2.30 [ .091 ]	± 0.25 [ .010 ]
D	0.65 [ .026 ]	± 0.45 [ .018 ]

# H11812V101R-10

**UNCONTROLLED DOCUMENT**

**Z vs FREQUENCY  
IMPEDANCE UNDER DC BIAS**

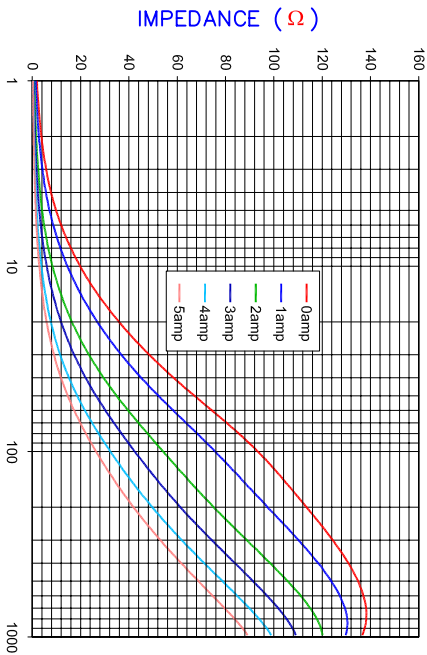

**|Z|, R, AND X vs. FREQUENCY**

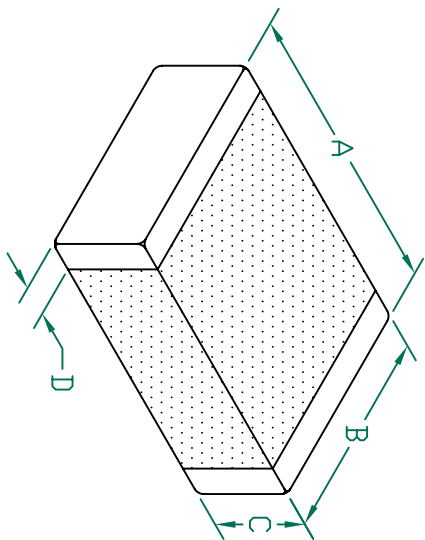
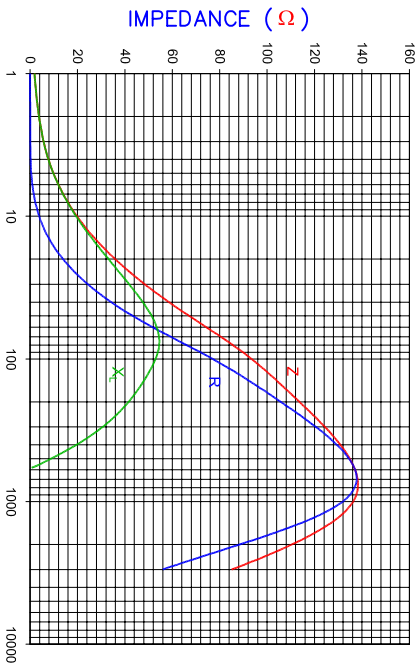

**ELECTRICAL CHARACTERISTICS:**

Z @ 100MHz ( Ω )	DCR ( Ω )	Rated Current
Nominal 100		
Minimum 75		
Maximum 125	0.007	8000 mA

NOTES: UNLESS OTHERWISE SPECIFIED

1. TAPED AND REELED per CURRENT EIA SPECIFICATIONS 13" REELS, 2500 PCS/REEL.
2. TERMINATION FINISH IS 100% TIN.
3. COMPONENTS SHOULD BE ADEQUATELY PREHEATED BEFORE SOLDERING.



**LAND PATTERNS FOR REFLOW SOLDERING**

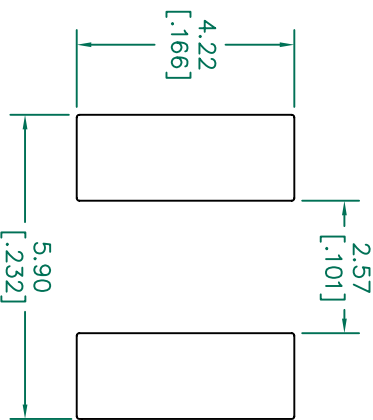

(For wave soldering, add 0.762 [ .030 ] to this dimension)

**RECOMMENDED SOLDERING CONDITIONS**

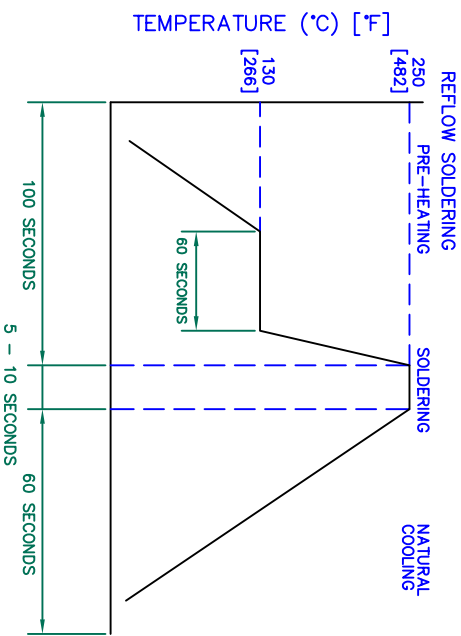

DIMENSIONS ARE IN mm [INCHES].

This print is the property of Laird Tech and is loaned in confidence subject to return upon request and with the understanding that no copies shall be made without the written consent of Laird Tech. All rights to design or invention are reserved.



A		B		C	
REV	DESCRIPTION	DATE	INT	DATE	INT
		04/02/04	TMB	11/06/09	JUN
PROJECT/PART NUMBER:		H11812V101R-10		REV: C	
SCALE:		04/02/04		PART TYPE: CO-FIRE	
DRAWN BY: TMB		SHEET: 2 of 2		DATE: 04/02/04	