

Würth Elektronik eiSos GmbH & Co. KG

EMC & Inductive Solutions

Max-Eyth-Straße 1 · 74638 Waldenburg · Germany

Tel. +49 (0) 79 42 945-0 · Fax +49 (0) 79 42 945-400

eiSos@we-online.de · www.we-online.de



## Product/Process Change Notice (PCN)

- Major change  
 Minor change

PCN #: WE\_CMBH\_20161230

Product Affected: WE-CMBH series

PCN Date: December 30<sup>th</sup> 2016

Effective Date: April 01<sup>st</sup> 2017

- Product Mark  
 Date Code  
 Packaging  
 Others

Contact: Product Management

Phone: +49 (0) 7942 - 945 5001

Fax: +49 (0) 7942 - 945 5179

E-mail: pcn.eisos@we-online.de

Attachment:  Yes  No

Samples:

### DESCRIPTION AND PURPOSE OF CHANGE:

We will add a gluing process in production lines for our WE-CMBH series. There will be no change in fit or function of the product.

### DETAIL OF CHANGE:

Due to the continuous product improvement process, Würth Elektronik will glue the choke ends on the base plate. Toroidal core will also be fixed on the top with the same glue.  
The used material will be Epoxy Glue EPORITE 2080(XX) with UL File number: E105126.

As the pins are not movable anymore, the pin length tolerance will be decreased from  $\pm 1,0$  mm to  $\pm 0,5$  mm

For more details refer to next page

Würth Elektronik eiSos GmbH & Co. KG

EMC & Inductive Solutions

Max-Eyth-Straße 1 · 74638 Waldenburg · Germany

Tel. +49 (0) 79 42 945-0 · Fax +49 (0) 79 42 945-400

eiSos@we-online.de · www.we-online.de

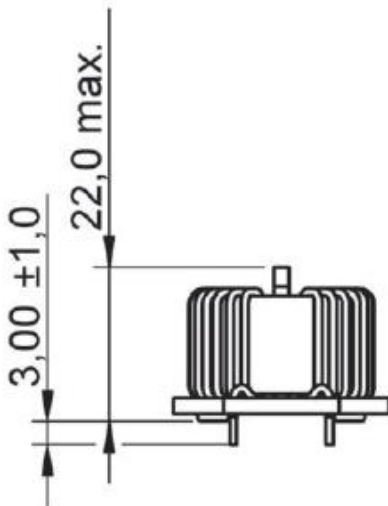
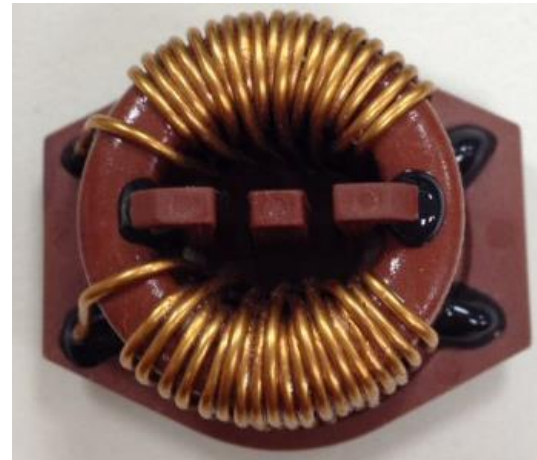
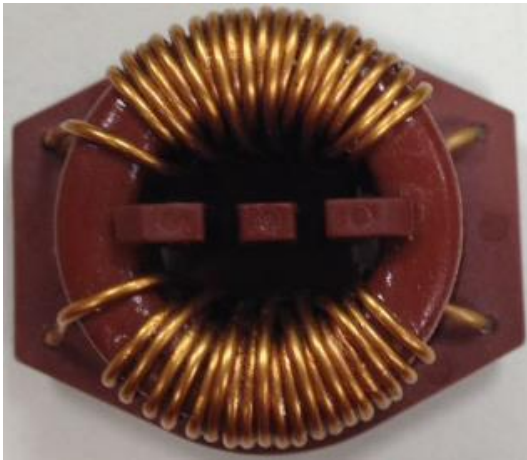

Before change

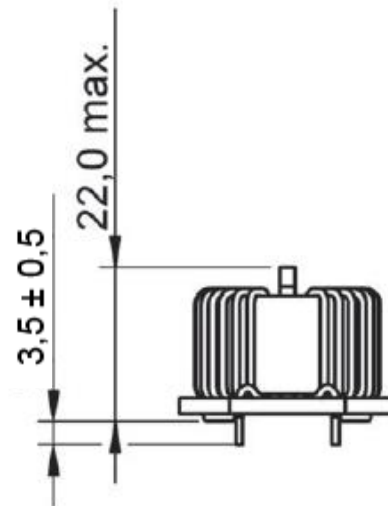

After change

**RELIABILITY / QUALIFICATION SUMMARY:**

Product approval is according to the specification and is internally released by the Product Management Department.]

**DATA SHEET CHANGE:**

Yes

No