

# PTSLR1210

## Low resistance SMD PTC fuses



### Applications

- Data ports
- Micromotors and fans
- Low voltage test and measurement
- Low voltage hand held equipment
- PC-based medical equipment
- USB protection
- Secondary Li-ion battery protection
- Game consoles, set top boxes

### Product features

- Positive temperature coefficient (PTC)
- Surface mount resettable fuse
- Low resistance
- Compact 1210 (3225 metric) footprint
- Voltage rating 6 V
- Current rating from 1.75 A to 5.00 A
- Fast time-to-trip

### Agency information

- cULRus Recognized file no. E343021
- TUV: File R 50455924

### Part number system/ordering:

#### PTSLR12106V175

- PT= PTC resettable fuse
- S= Surface mount
- LR= Low resistance
- 1210= Dimension code
- 6V= Maximum voltage
- 175= Ihold current rating (175= 1.75 A)

**Product specifications**

Part number	V <sub>max</sub> <sup>1</sup>	I <sub>max</sub> <sup>2</sup>	I <sub>hold</sub> <sup>3</sup>	I <sub>trip</sub> <sup>4</sup>	P <sub>d</sub> <sup>5</sup>	Time-to-trip (maximum)		Resistance <sup>6</sup>		Safety approvals		
	(V <sub>dc</sub> )	(A)	(A)	(A)	typical (W)	(A)	(seconds)	Initial (R <sub>i</sub> ) minimum (Ω)	Post trip (R <sub>t</sub> ) maximum (Ω)	Part marking	cURus	TÜV
PTSLR12106V175	6	50	1.75	3.5	0.8	8.0	2.5	0.006	0.040	LA	√	√
PTSLR12106V200	6	50	2.00	4.0	0.8	8.0	3.0	0.005	0.024	LB	√	√
PTSLR12106V260	6	50	2.60	5.0	0.8	8.0	4.0	0.003	0.020	LE	√	√
PTSLR12106V300	6	50	3.00	6.0	0.8	15	2.0	0.003	0.020	LG	√	√
PTSLR12106V350	6	50	3.50	7.0	0.8	17.5	2.0	0.003	0.018	LN	√	√
PTSLR12106V380	6	50	3.80	8.0	0.8	19	2.0	0.003	0.016	LK	√	√
PTSLR12106V400	6	50	4.00	8.0	0.8	20	2.0	0.002	0.014	LM	√	√
PTSLR12106V450	6	50	4.50	9.0	0.8	22.5	2.0	0.002	0.014	LP	√	√
PTSLR12106V500	6	50	5.00	10	0.8	25	2.0	0.002	0.012	LQ	√	√

1. V<sub>max</sub>: Maximum continuous voltage the device can withstand without damage at rated current
2. I<sub>max</sub>: Maximum fault current the device can withstand without damage at rated voltage
3. I<sub>hold</sub>: Maximum current the device will pass without interruption at +23 °C still air unless otherwise specified
4. I<sub>trip</sub>: Minimum current that will transition the device from low resistance to high resistance at +23 °C still air, unless otherwise specified

5. P<sub>d</sub>: Power dissipated from the device when in tripped state at +23 °C still air, unless otherwise specified
6. R<sub>i</sub>: Minimum resistance of the device prior to tripping at +23 °C  
R<sub>t</sub>: Maximum resistance of the device one hour after tripping at +23 °C

**Dimensions—mm**

**Recommended pad layout**

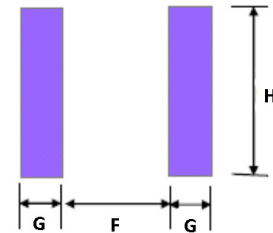
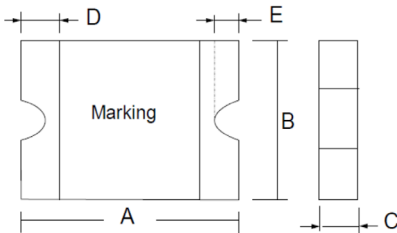

A min	A max	B min	B max	C min	C max	D min	D max	E max	E max	F	G	H
3.00	3.43	2.35	2.80	0.40*	0.70*	0.13	0.75	0.08	0.50	2.0	1.0	2.8
				0.60**	1.2**							

\* PTSLR12106V175, PTSLR12106V200, PTSLR12106V260

\*\* PTSLR12106V300, PTSLR12106V350, PTSLR12106V380, PTSLR12106V400, PTSLR12106V450, PTSLR12106V500

**Thermal derating curve**

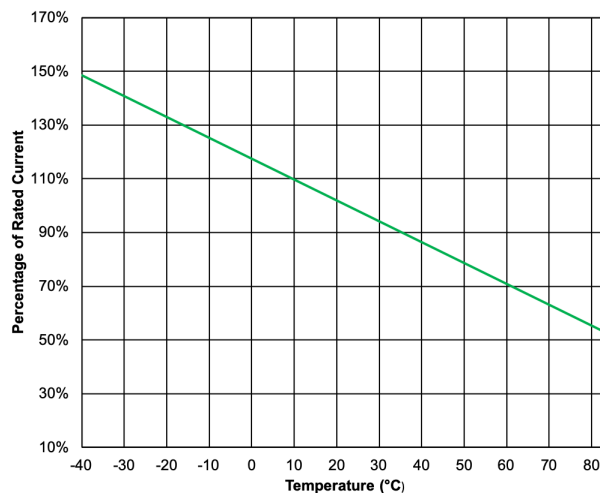

**General specifications**

Operating temperature: -40 °C to +85 °C (with derating)
Storage temperature: -10 °C to +40 °C
Storage relative humidity: ≤75%
Storage condition: Keep away from corrosive atmosphere and sunlight
Passive aging: IEC60738-1, +85 °C, 1000 hours
Humidity aging: +85 °C, 80 to 85% relative humidity, 100 hours
Rapid change of temperature: IEC60738-1, +85 °C to -40 °C, 20 cycles, 30 minutes each
Overload endurance: UL1434, Vmax, 120% Imax, 50 cycles Vmax, 300% Itrip, 6000 cycles
Trip endurance: UL1434, Vmax, Itrip ± Imax, 1000 hours
Solderability: IEC60068-2-58, +245 °C, 3 seconds
Moisture sensitivity test: J-STD-020, MSL=2a

**Packaging information**

Supplied in tape and reel packaging, 3000 parts per 7.0" (178 mm) diameter reel

**Taping specification**

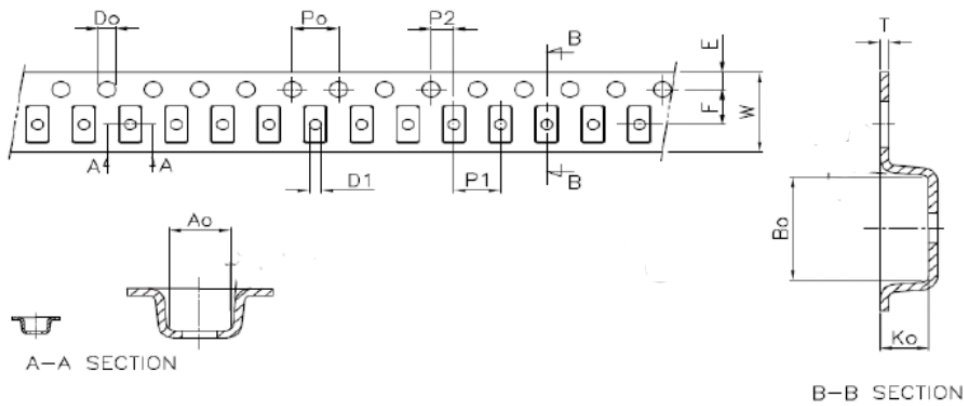

$A_0$	$B_0$	$K_0$	$P_0$	$P_1$	$P_2$	$T$	$E$	$F$	$D_0$	$D_1$	$W$	$10P_0$
± 0.10	± 0.10	± 0.05	± 0.10	± 0.10	± 0.10	± 0.05	± 0.10	± 0.10	± 0.05	min	± 0.30	± 0.20
2.82	3.63	1.47	4.0	4.0	2.0	0.23	1.75	3.50	1.55	1.0	8.0	40

### Wave solder profile

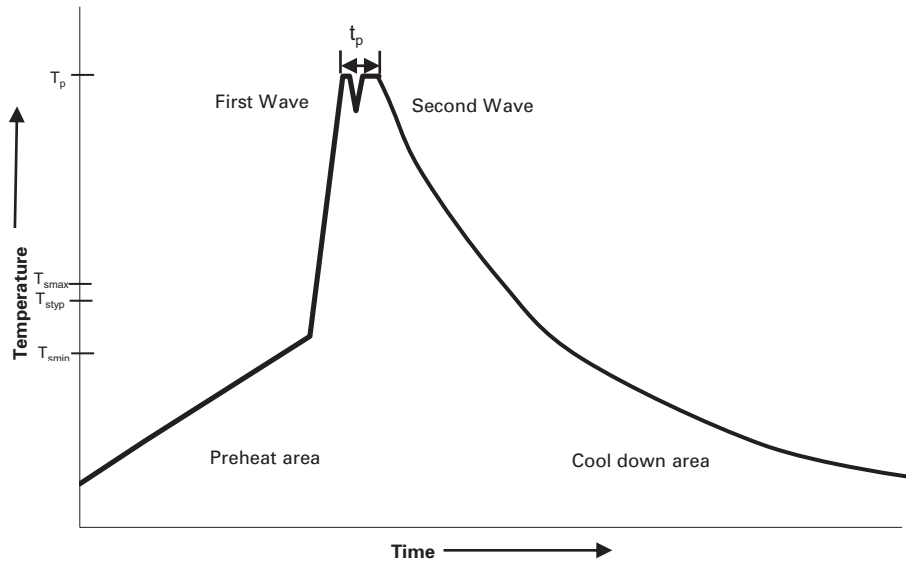

### Reference EN 61760-1:2006

Profile feature	Standard SnPb solder	Lead (Pb) free solder
Preheat		
• Temperature min. ( $T_{smin}$ )	100 °C	100 °C
• Temperature typ. ( $T_{styp}$ )	120 °C	120 °C
• Temperature max. ( $T_{smax}$ )	130 °C	130 °C
• Time ( $T_{smin}$ to $T_{smax}$ ) ( $t_s$ )	70 seconds	70 seconds
$\Delta$ preheat to max Temperature	150 °C max.	150 °C max.
Peak temperature ( $T_p$ )*	235 °C – 260 °C	250 °C – 260 °C
Time at peak temperature ( $t_p$ )	10 seconds max 5 seconds max each wave	10 seconds max 5 seconds max each wave
Ramp-down rate	~ 2 K/s min ~3.5 K/s typ ~5 K/s max	~ 2 K/s min ~3.5 K/s typ ~5 K/s max
Time 25°C to 25°C	4 minutes	4 minutes

### Manual solder

+350 °C (4-5 seconds by soldering iron), generally manual/hand soldering is not recommended

Solder reflow profile

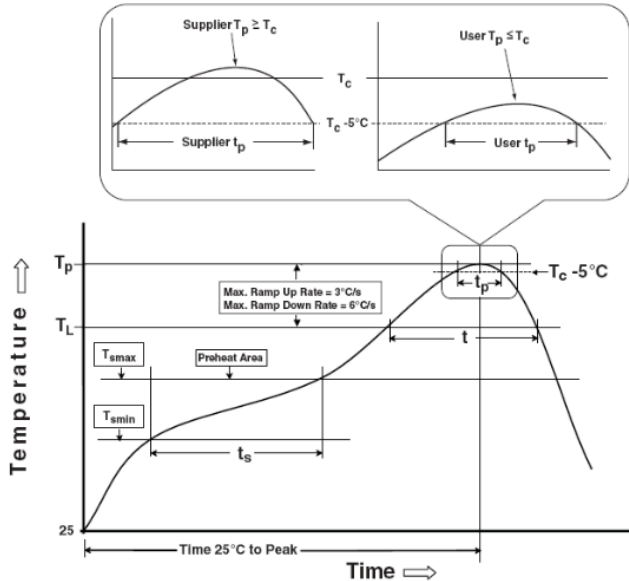

Table 1 - Standard SnPb solder ( $T_c$ )

Package thickness	Volume $\text{mm}^3$ <350	Volume $\text{mm}^3$ $\geq$ 350
<2.5 mm)	235 °C	220 °C
$\geq$ 2.5 mm	220 °C	220 °C

Table 2 - Lead (Pb) free solder ( $T_c$ )

Package thickness	Volume $\text{mm}^3$ <350	Volume $\text{mm}^3$ 350 - 2000	Volume $\text{mm}^3$ >2000
<1.6 mm	260 °C	260 °C	260 °C
1.6 – 2.5 mm	260 °C	250 °C	245 °C
>2.5 mm	250 °C	245 °C	245 °C

Reference J-STD-020

Profile feature	Standard SnPb solder	Lead (Pb) free solder
Preheat and soak		
• Temperature min. ( $T_{smin}$ )	100 °C	150 °C
• Temperature max. ( $T_{smax}$ )	150 °C	200 °C
• Time ( $T_{smin}$ to $T_{smax}$ ) ( $t_s$ )	60-120 seconds	60-120 seconds
Ramp up rate $T_L$ to $T_p$	3 °C/ second max.	3 °C/ second max.
Liquidous temperature ( $T_L$ )	183 °C	217 °C
Time ( $t_L$ ) maintained above $T_L$	60-150 seconds	60-150 seconds
Peak package body temperature ( $T_p$ )*	235 °C	260 °C
Time ( $t_p$ )* within 5 °C of the specified classification temperature ( $T_c$ )	20 seconds*	30 seconds*
Ramp-down rate ( $T_p$ to $T_L$ )	6 °C/ second max.	6 °C/ second max.
Time 25 °C to peak temperature	6 minutes max.	8 minutes max.

\* Tolerance for peak profile temperature ( $T_p$ ) is defined as a supplier minimum and a user maximum.

Life Support Policy: Eaton does not authorize the use of any of its products for use in life support devices or systems without the express written approval of an officer of the Company. Life support systems are devices which support or sustain life, and whose failure to perform, when properly used in accordance with instructions for use provided in the labeling, can be reasonably expected to result in significant injury to the user.

Eaton reserves the right, without notice, to change design or construction of any products and to discontinue or limit distribution of any products. Eaton also reserves the right to change or update, without notice, any technical information contained in this bulletin.

**Eaton**  
Electronics Division  
1000 Eaton Boulevard  
Cleveland, OH 44122  
United States  
Eaton.com/electronics

© 2020 Eaton  
All Rights Reserved  
Printed in USA  
Publication No. 11049 BU-MC20026  
March 2020

Eaton is a registered trademark.

All other trademarks are property of their respective owners.

Follow us on social media to get the latest product and support information.

