

- 1
- 2
- 3
- 4
- 5
- 6
- 7
- 8
- 9
- 10
- 11
- 12
- 13
- 14
- 15
- 16
- 17
- 18

MATERIAL

Glass-fibre reinforced polyamide based (PA) technopolymer, black colour, matte finish.

BOSS CAP

CA.VCT: polypropylene-based (PP) technopolymer, in Elecolors colours, matte finish, press-fit assembly. Supplied. Available also as accessory sold separately (see table).

STANDARD EXECUTIONS

- VTT-C-B: brass boss, threaded pass-through hole.
- VTT-C-p: zinc-plated steel threaded stud, chamfered flat end according to UNI 947 : ISO 4753 (see Technical data on page A-11).

FEATURES AND APPLICATIONS

The three-lobe shape with large recesses is particularly ergonomic also for smaller knobs, ensuring an effective grip even with work gloves.

ACCESSORIES ON REQUEST

CA.VCT: polypropylene-based (PP) technopolymer boss cap, in Elecolors colours, matte finish, press-fit assembly. It can be supplied in other colours or with customised graphic symbols, marks or writings.

SPECIAL EXECUTIONS ON REQUEST

Handwheels with stainless steel metal parts.



ELESA Original design

- C2 RAL2004
- C3 RAL7035
- C4 RAL1021
- C5 RAL5024
- C6 RAL3000
- C17 RAL6017

CA.VCT

	C2	C3	C4	C5	C6	C17	
Cap for	Code						Description
VTT.32-C	6923	6924	6925	6926	6921	6927	CA.VCT.50-*
VTT.40-C	6933	6934	6935	6936	6931	6937	CA.VCT.63-74-95*
VTT.50-C	6983	6984	6985	6986	6981	6987	CA.VCT.84-*

* Complete with colour index (C2, ..., C17).

VTT-C-B

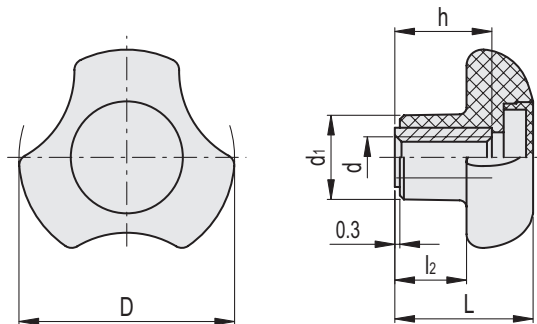

* Complete with colour index, example: 167716-C2 VTT.32-C-B-M6-C2

- C2 RAL2004
- C3 RAL7035
- C4 RAL1021
- C5 RAL5024
- C6 RAL3000
- C17 RAL6017

VTT-C-B

Code	Description	D	d6H	L	d1	l2	h	△
167716-*	VTT.32-C-B-M6-*	32	M6	22	14	11.5	14	15
167717-*	VTT.32-C-B-M8-*	32	M8	22	14	11.5	14	14
167835-*	VTT.40-C-B-M6-*	40	M6	25	16	13.5	18	24
167836-*	VTT.40-C-B-M8-*	40	M8	25	16	13.5	18	22
167965-*	VTT.50-C-B-M8-*	50	M8	29	19	15	20	43
167966-*	VTT.50-C-B-M10-*	50	M10	29	19	15	20	40

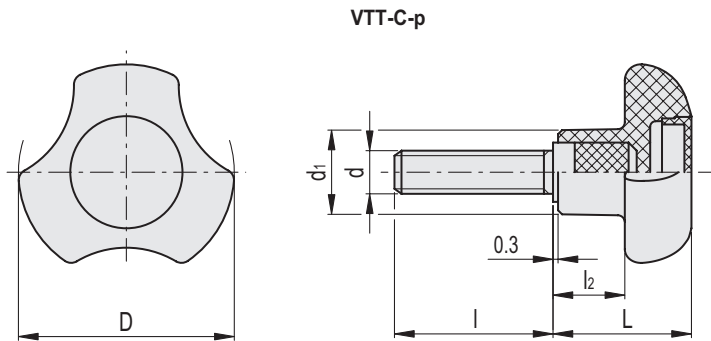

* Complete with colour index, example: 167752-C2 VTT.32-C-p-M6x16-C2

C2 RAL2004 C3 RAL7035 C4 RAL1021 C5 RAL5024 C6 RAL3000 C17 RAL6017

VTT-C-p

Code	Description	D	d6g	L	d1	l	l2	⚖️
167752-*	VTT.32-C-p-M6x16-*	32	M6	22	14	16	11.5	17
167753-*	VTT.32-C-p-M6x20-*	32	M6	22	14	20	11.5	19
167755-*	VTT.32-C-p-M6x25-*	32	M6	22	14	25	11.5	21
167754-*	VTT.32-C-p-M6x30-*	32	M6	22	14	30	11.5	23
167757-*	VTT.32-C-p-M6x35-*	32	M6	22	14	35	11.5	25
167758-*	VTT.32-C-p-M6x40-*	32	M6	22	14	40	11.5	27
167759-*	VTT.32-C-p-M6x45-*	32	M6	22	14	45	11.5	29
167772-*	VTT.32-C-p-M8x16-*	32	M8	22	14	16	11.5	20
167773-*	VTT.32-C-p-M8x20-*	32	M8	22	14	20	11.5	22
167774-*	VTT.32-C-p-M8x25-*	32	M8	22	14	25	11.5	24
167775-*	VTT.32-C-p-M8x30-*	32	M8	22	14	30	11.5	27
167776-*	VTT.32-C-p-M8x35-*	32	M8	22	14	35	11.5	30
167851-*	VTT.40-C-p-M6x10-*	40	M6	25	16	10	13.5	29
167853-*	VTT.40-C-p-M6x16-*	40	M6	25	16	16	13.5	31
167855-*	VTT.40-C-p-M6x20-*	40	M6	25	16	20	13.5	33
167857-*	VTT.40-C-p-M6x25-*	40	M6	25	16	25	13.5	35
167859-*	VTT.40-C-p-M6x30-*	40	M6	25	16	30	13.5	37
167861-*	VTT.40-C-p-M6x40-*	40	M6	25	16	40	13.5	40
167870-*	VTT.40-C-p-M8x16-*	40	M8	25	16	16	13.5	32
167871-*	VTT.40-C-p-M8x20-*	40	M8	25	16	20	13.5	34
167872-*	VTT.40-C-p-M8x25-*	40	M8	25	16	25	13.5	36
167873-*	VTT.40-C-p-M8x30-*	40	M8	25	16	30	13.5	38
167874-*	VTT.40-C-p-M8x35-*	40	M8	25	16	35	13.5	40
167875-*	VTT.40-C-p-M8x40-*	40	M8	25	16	40	13.5	42
167877-*	VTT.40-C-p-M8x50-*	40	M8	25	16	50	13.5	46
167880-*	VTT.40-C-p-M8x55-*	40	M8	25	16	55	13.5	48
167878-*	VTT.40-C-p-M8x60-*	40	M8	25	16	60	13.5	50
167879-*	VTT.40-C-p-M8x70-*	40	M8	25	16	70	13.5	54
167941-*	VTT.50-C-p-M8x16-*	50	M8	29	19	16	15	53
167943-*	VTT.50-C-p-M8x20-*	50	M8	29	19	20	15	55
167945-*	VTT.50-C-p-M8x25-*	50	M8	29	19	25	15	57
167947-*	VTT.50-C-p-M8x30-*	50	M8	29	19	30	15	60
167949-*	VTT.50-C-p-M8x40-*	50	M8	29	19	40	15	64
167951-*	VTT.50-C-p-M8x45-*	50	M8	29	19	45	15	66
167953-*	VTT.50-C-p-M8x50-*	50	M8	29	19	50	15	69
167955-*	VTT.50-C-p-M8x60-*	50	M8	29	19	60	15	72
167981-*	VTT.50-C-p-M10x20-*	50	M10	29	19	20	15	56
167982-*	VTT.50-C-p-M10x25-*	50	M10	29	19	25	15	58
167983-*	VTT.50-C-p-M10x30-*	50	M10	29	19	30	15	61
167984-*	VTT.50-C-p-M10x35-*	50	M10	29	19	35	15	63
167985-*	VTT.50-C-p-M10x40-*	50	M10	29	19	40	15	66
167986-*	VTT.50-C-p-M10x45-*	50	M10	29	19	45	15	69
167988-*	VTT.50-C-p-M10x55-*	50	M10	29	19	55	15	72



Clamping knobs