

19" chassis - *multipacPRO*

19" complete chassis from aluminium with plain top cover and base plate



- Complete chassis from aluminium
- Detachable rear panel for easy machining
- EMC shielding of approx. 30 dB(A) at 1 GHz (without additional shielding material)
- In accordance with standard IEC 60297-3-100, -101, -105
- In the 1 U version 19" and ATX power supplies can be assembled up to a clearance of 35 mm

Delivery comprises (Kit)

Item	Qty	Description
1	1	Front panel, Al extrusion, 3 mm; in 1 U: front anodised, rear etched; from 2 U: front and rear side of front panels clear passivated
2	1	Rear panel, Al, 2 mm, etched
3	1	Base plate, plain, Al, 1 mm
4	1	Cover plate, plain, Al, 1 mm
5	2	Side panel, Al extrusion, raw; with grooves for threaded insert (2 x 7); 5 U, two-piece, 3+2 U
6	1	Assembly kit

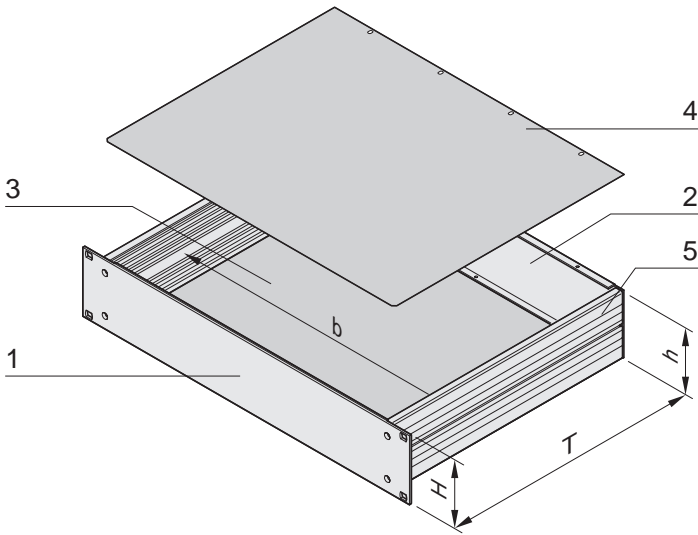

h = clear height (overall) (H - 8.1 mm)
 b = clear installation width = 403 mm

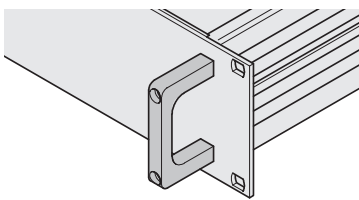

Front handle



ServicePLUS see page 6.118

Order Information

Height U	Height H mm	Depth T mm	Part no. Kit
1	43.7	220	20860-601
1	43.7	280	20860-602
2	88.1	280	20860-605
2	88.1	340	20860-606
3	132.6	280	20860-607
3	132.6	340	20860-608
3	132.6	400	20860-609
4	177.0	340	20860-612
4	177.0	400	20860-613
4	177.0	460	20860-614
5	221.5	460	20860-615

EMC gasketing kit Silicone/nickel gasket 2100 mm for contacting side panel/cover plate; seal, stainless steel, for front panel/cover plate, 1 kit 20860-130

Front handles incl. assembly kit for 1 U, Al extrusion, anodised, PU 2 pieces 20860-256

Front handles incl. assembly kit for 2 U, Al extrusion, anodised, PU 2 pieces 20860-257

Front handles incl. assembly kit for 3 U, Al extrusion, anodised, PU 2 pieces 20860-258

Front handles incl. assembly kit for 4 U, Al extrusion, anodised, PU 2 pieces 20860-259

Front handles incl. assembly kit for 5 U, Al extrusion, anodised, PU 2 pieces 20860-260

Note

- Threaded inserts to push into the side panel see page 6.121
- Telescopic slides to mount into cabinet see page 6.125