

1 YEAR
WARRANTY

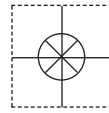

Ω OMEGA® User's Guide

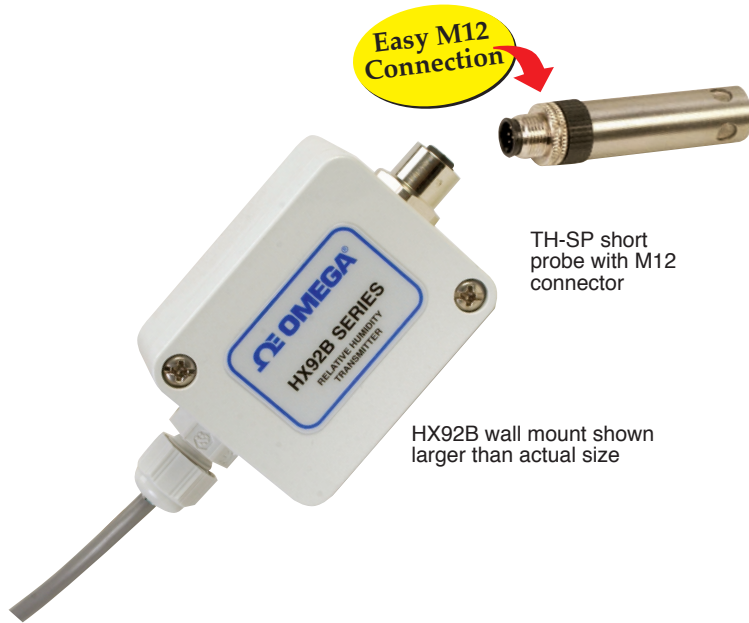

Easy M12
Connection

TH-SP short
probe with M12
connector

HX92B wall mount shown
larger than actual size

**Shop online at
omega.com®**

**e-mail: info@omega.com
For latest product manuals:
www.omegamanual.info**



HX92B(*)-D duct mount
transmitter shown smaller
than actual size

TH-RP remote
probe with 3 m
(10') cable
and M12
connector

HX92B SERIES Relative Humidity Transmitters



omega.com info@omega.com

Servicing North America:

U.S.A.:

Omega Engineering, Inc., One Omega Drive, P.O. Box 4047
Stamford, CT 06907-0047 USA

Toll-Free: 1-800-826-6342 (USA & Canada only)

Customer Service: 1-800-622-2378 (USA & Canada only)

Engineering Service: 1-800-872-9436 (USA & Canada only)

Tel: (203) 359-1660

Fax: (203) 359-7700

e-mail: info@omega.com

For Other Locations Visit omega.com/worldwide

The information contained in this document is believed to be correct, but OMEGA accepts no liability for any errors it contains, and reserves the right to alter specifications without notice.

WARNING: These products are not designed for use in, and should not be used for, human applications.

Patented: Covered by U.S. and International Patents and Patents Pending.



Table of Contents

Section	Page
1. General Description	1-1
2. Unpacking	2-1
3. Theory of Operation and Electrical Connection	3-1
3.1.1 Theory Operation	3-1
4. Mounting	4-1
5. Relative Humidity Output Calculations	5-1
6. Calibration	6-1
7. Maintenance	7-1
8. Specifications	8-1



List of Figures

Figure	Description	Page
Figure 1-1	Transmitter Internal Diagram	1-1
Figure 3-1	Voltage Output Connection Diagram	3-1
Figure 3-2	Current Output Connection Diagram	3-2
Figure 4-1	Wall Mount Model Dimensions	4-1
Figure 4-2	Duct Mount Model Dimensions	4-2
Figure 4-3	Remote Probe Model Dimensions	4-2
Figure 7-1	Sensor Probe Replacement	7-1

Section 1 - General Description

The OMEGA® HX92B Series Relative Humidity Transmitter provides a linearized and temperature compensated output signal of 4 to 20mA, 0 to 1 Vdc, 0 to 5 Vdc or 0 to 10 Vdc depending upon the model selected. The output signals have been calibrated and scaled 0 to 100% Relative Humidity output scale. The digital Relative Humidity sensor is protected by a stainless steel filter that is easily removed for cleaning. The NEMA rated polycarbonate enclosure and cable entry connection provides weathertight protection. Screws are provided for mounting via internal holes inside the enclosure. The terminal connection for the output signal is as shown in Figure 1-1 below.

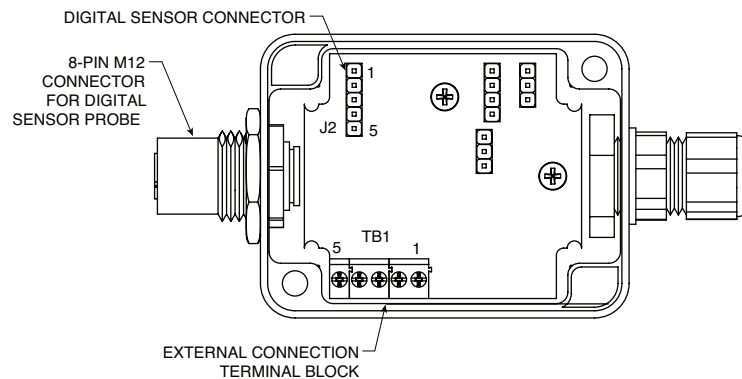

Figure 1-1. Transmitter Internal Diagram

Most of the models come with a replaceable sensor probe; the process of replacing the sensor probe is very simple. See the "Maintenance" section for details.

The models with a replaceable sensor probe are:

HX92BC, HX92BV0, HX92BV1, HX92BV2, HX92BC-RP1, HX92BV0-RP1, HX92BV1-RP1, HX92BV2-RP1.

The models without a replaceable sensor probe are:

HX92BC-D, HX92BV0-D, HX92BV1-D, HX92BV2-D.

Section - 2 Unpacking

Remove the packing list and verify that you have received all your equipment. If you have any questions about the shipment, please call our Customer Service Department at 1-800-622-2378 or 203-359-1660.

On the web you can find us at: www.omega.com e-mail: cservice@omega.com

When you receive the shipment, inspect the container and equipment for any signs of damage. Note any evidence of rough handling in transit. Immediately report any damage to the shipping agent.

NOTE:

The carrier will not honor any damage claims unless all shipping material is saved for inspection. After examining and removing contents, save packing material and carton in the event reshipment is necessary.

The following items are supplied in the box with your HX92B Series transmitter.

- HX92B Series Quick start Manual, MQS-5339 (1 ea.)
- #6 Wall Anchor and #6 Mounting Screw (2 ea.)

2.1 HX92B available models and functional description

Model number	Description
HX92BC	Wall Mount Relative Humidity Transmitter, 4 to 20mA.
HX92BV0	Wall Mount Relative Humidity Transmitter, 0 to 1 volt.
HX92BV1	Wall Mount Relative Humidity Transmitter, 0 to 5 volt.
HX92BV2	Wall Mount Relative Humidity Transmitter, 0 to 10 volt.
HX92BC-D	Duct Mount Relative Humidity Transmitter, 4 to 20mA.
HX92BV0-D	Duct Mount Relative Humidity Transmitter, 0 to 1 volt.
HX92BV1-D	Duct Mount Relative Humidity Transmitter, 0 to 5 volt.
HX92BV2-D	Duct Mount Relative Humidity Transmitter, 0 to 10 volt.
HX92BC-RP1	Remote Probe Relative Humidity Transmitter, 4 to 20mA Output with 3 m (10') cable.
HX92BV0-RP1	Remote Probe Relative Humidity Transmitter, 0 to 1 volt output with 3 m (10') cable.
HX92BV1-RP1	Remote Probe Relative Humidity Transmitter, 0 to 5 volt out put with 3 m (10') cable.
HX92BV2-RP1	Remote Probe Relative Humidity Transmitter, 0 to 10 volt output with 3 m (10') cable.

Accessories

Model number	Description
TH-RP	Field replaceable remote probe with 3 m (10') cable and M12 connector.
TH-SP	Field replaceable 71.88 L mm (2.83") short probe with M12 connector.
HX92-CAL	Calibration Kit and 75% relative humidity standards.
IND-KIT	Spare duct mount kit for HX92(*), HX92B(*)-D or HX92B(*)-RP1

*For 4 to 20 mA output specify "C", for 0 to 1 Vdc output specify "V0", for 0 to 5 Vdc output specify "V1", and for 0 to 10 Vdc output specify "V2".

Section 3 – Theory of Operation and Electrical Connection

3.1.1 Theory of Operation

A 4 to 20 mA loop is a series loop in which a transmitter will vary the current flow depending on the input to the transmitter. In the HX92B the amount of the current allowed to flow in the loop will vary depending on the relative humidity being measured by the sensor. Some advantages of a current output over a voltage output is that the signal measured is less susceptible to electrical noise interference, and the loop can support more than one measuring instrument as long as the maximum loop resistance is not exceeded.

A typical application utilizing a current loop will normally consist of a power supply, the transmitter and a meter, recorder or controller to measure the current flow. The maximum allowable loop resistance for the HX92B to function properly is found by using the following formula:

$$R_{max} = ((\text{power supply voltage} - 4) \div .02)$$

EXAMPLE: (When using a 30 Vdc power supply).

$$R_{max} = ((30 - 4) \div .02) = 1,300 \text{ ohms max loop resistance}$$

CAUTION:

All electrical connections and wiring should be performed by a suitably trained professional only.

Follow the electrical connection diagram shown in figure 3-1 and 3-2 below to set up your Relative Humidity Transmitter.

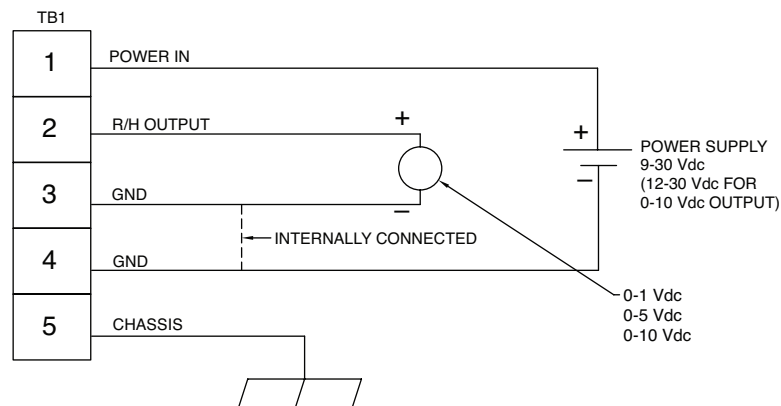

Figure 3-1. Voltage Output Connection Diagram

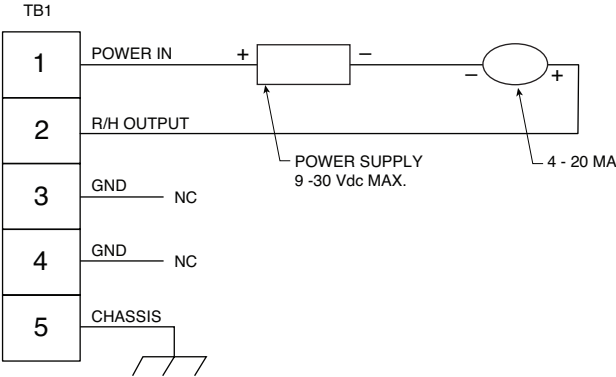

Figure 3-2. Current Output Connection Diagram

Section 4 - Mounting

The HX92B transmitters are designed for wall, duct or remote probe mounting depending upon the model. Plastic wall anchors and mounting screws are included with Wall Mount and Remote Probe models. A duct mounting kit is included with Duct Mount models.

See Figure 4-1, Figure 4-2 and Figure 4-3 for the Wall Mount, Duct Mount and Remote Probe model dimensions for your mounting reference.

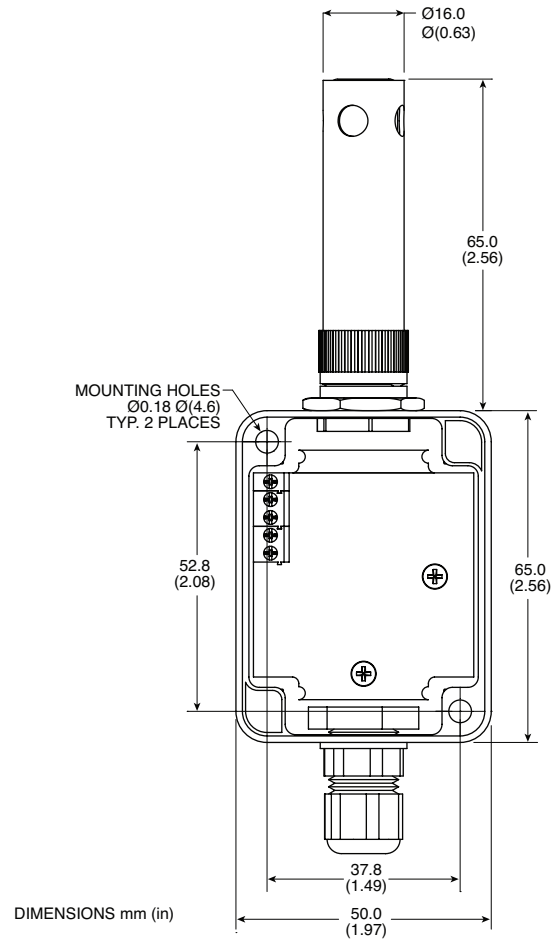

Figure 4-1. Wall Mount Model Dimensions

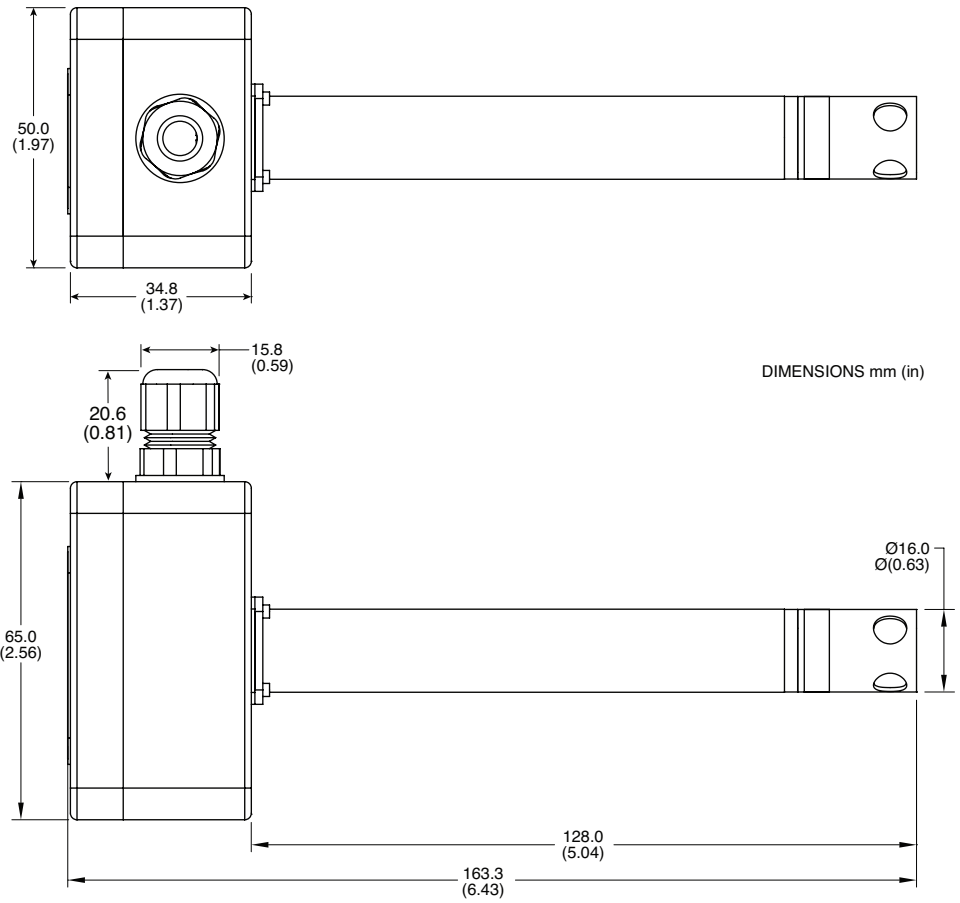

Figure 4-2. Duct Mount Model Dimensions

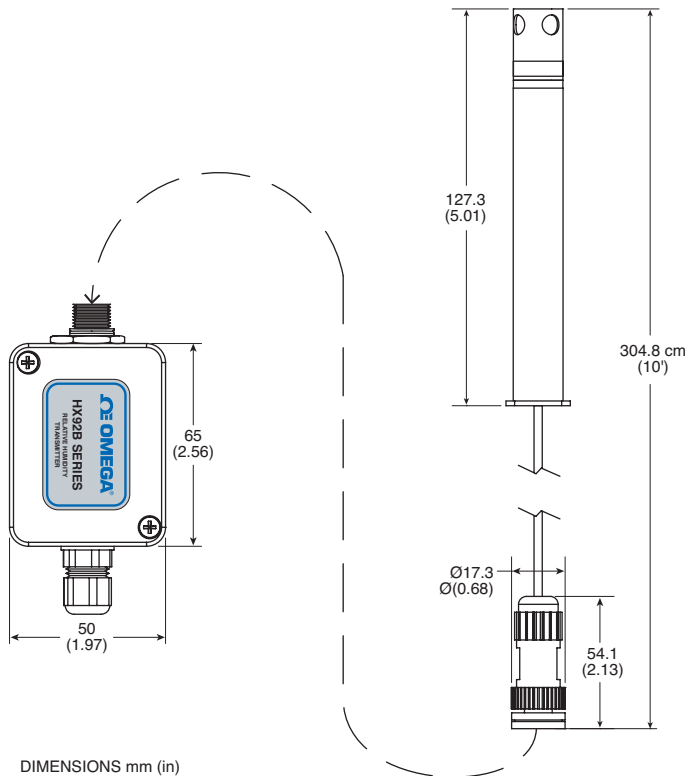

Figure 4-3 Remote Probe Model Dimensions

Section 5 - Relative Humidity Output Calculations

To calculate % relative humidity by measuring the current or voltage output, use the following formulas:

For current output:

$$\%RH = (\text{Current measured in milliamps} - 4) \div 0.16$$

Where:

4 = offset current in mA.

0.16 = full scale current limit in percent (%).

For voltage output

a. 1 volt output:

$$\%RH = (\text{voltage measured in volts} \times 100)$$

b. 5 volt output:

$$\%RH = (\text{voltage measured in volts} / 5) \times 100$$

c. 10 volt output:

$$\%RH = (\text{voltage measured in volts} / 10) \times 100$$

RH Measured Vs Output Reading				
% Relative Humidity	Output			
	Current (mA)	0 to 1 Volt (Vdc)	0 to 5 Volt (Vdc)	0 to 10 Volt (Vdc)
1	4.16	0.01	0.05	0.10
2	4.32	0.02	0.10	0.20
3	4.48	0.03	0.15	0.30
4	4.64	0.04	0.20	0.40
5	4.80	0.05	0.25	0.50
10	5.60	0.10	0.50	1.00
15	6.40	0.15	0.75	1.50
20	7.20	2.20	1.00	2.00
25	8.00	0.25	1.25	2.50
30	8.80	0.30	1.50	3.00
35	9.60	0.35	1.75	3.50
40	10.40	0.40	2.00	4.00
45	11.20	0.45	2.25	4.50
50	12.00	0.50	2.50	5.00
55	12.80	0.55	2.75	5.50
60	13.60	0.60	3.00	6.00
65	14.40	0.65	3.25	6.50
70	15.20	0.70	3.50	7.00
75	16.00	0.75	3.75	7.50
80	16.80	0.80	4.00	8.00
85	17.60	0.85	4.25	8.50
90	18.40	0.90	4.50	9.00
95	19.20	0.95	4.75	9.50
100	20.00	1.00	5.00	10.00

Section 6 - Calibration

Your transmitter has been digitally calibrated and tested to meet or exceed the specifications outlined in this manual in our factory. The transmitter must be sent back to the factory for any re-calibration request.

Section 7 - Maintenance

The sensor probe can be replaced quickly for Wall Mount and Remote Probe models.

Procedure to replace the sensor probe:

- a. Loosen the securing nut, and pull the sensor probe out.
- b. Insert the new sensor probe to the M12 connector, and tighten the securing nut to secure the connection.

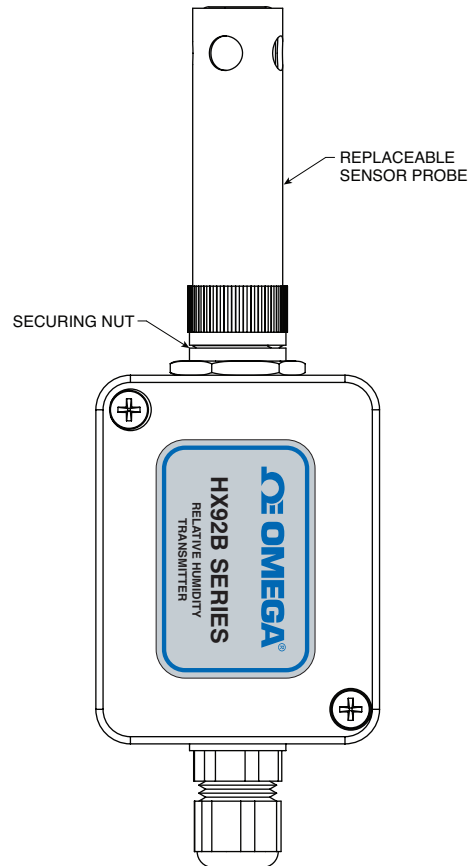

Figure 7-1 Sensor Probe Replacement

If your HX92B will be used in a dusty environment, the protective sensor filter (if clogged) may be removed for cleaning.

Unscrew the protective cover and gently blow compressed air through the filter screen. A soft brush may also be used to remove dirt particles from the screen.

If the sensor is subjected to 100% condensation, it must be dried to obtain correct readings. There will be no permanent damage or calibration shift to the unit.

Units should not be exposed to high concentrations of ammonia or alcohol vapors.

The Duct Mount model transmitter must be sent back to the factory if sensor replacement or recalibration is needed.

Section 8 - Specifications

Measuring Range:	0 to 100%
Accuracy Range:	±2.5% from 20 to 80% RH, ±3.5% from 5 to 20% and 80 to 95% RH; ±4% from 0 to 5% and 95 to 100% RH
Hysteresis:	±1%
Repeatability:	±0.1%
Resolution:	0.1%
Response Time:	8 Seconds typical
Sample Rate:	1 sample every 4 seconds.
Operating Temperature:	-30 to 75°C
Input Power	
4-20mA:	9 to 30 Vdc @ 50mV
0-1V:	9 to 30 Vdc @ 50mA
0-5V:	9 to 30 Vdc @ 50mA
0-10V:	12 to 30 Vdc @ 50mA
Max Loop Resistance:	200 Ohms @ 9 Vdc supply voltage
(4 to 20mA)	1,300 Ohms @ 30 Vdc supply voltage
	Ohms = ((V supply – 4 V) / .02 A)
	Max. Load (min. resistance)
Resistance:	1.25K for outputs: 0 – 1 Vdc, 0 – 5 Vdc
	2.40K for 0 – 10 Vdc output
Sensor Type:	Digital Sensor
Enclosure Housing:	Gray Polycarbonate, NEMA 13 (IP 54).
Connections:	Nylon, Liquid-tight with neoprene gland for 2.29 to 6.73 m (0.09 to 0.265") diameter cable, internal 5 position terminal block accepts wire size from 14 to 22 gauge wire.
Dimensions:	See "Mounting" Section
Weight:	
HX92B (*):	124 g (4.4 oz)
HX92B (*)-D:	132 g (4.7 oz)
HX92B (*)-RP1:	230 g (8.1 oz)

* 4 to 20 mA, 0 to 1 volt, 0 to 5 volts or 0 to 10 volts output. See page 2.2 for model numbers.



WARRANTY/DISCLAIMER

OMEGA ENGINEERING, INC. warrants this unit to be free of defects in materials and workmanship for a period of **13 months** from date of purchase. OMEGA's WARRANTY adds an additional one (1) month grace period to the normal **one (1) year product warranty** to cover handling and shipping time. This ensures that OMEGA's customers receive maximum coverage on each product.

If the unit malfunctions, it must be returned to the factory for evaluation. OMEGA's Customer Service Department will issue an Authorized Return (AR) number immediately upon phone or written request. Upon examination by OMEGA, if the unit is found to be defective, it will be repaired or replaced at no charge. OMEGA's WARRANTY does not apply to defects resulting from any action of the purchaser, including but not limited to mishandling, improper interfacing, operation outside of design limits, improper repair, or unauthorized modification. This WARRANTY is VOID if the unit shows evidence of having been tampered with or shows evidence of having been damaged as a result of excessive corrosion; or current, heat, moisture or vibration; improper specification; misapplication; misuse or other operating conditions outside of OMEGA's control. Components in which wear is not warranted, include but are not limited to contact points, fuses, and triacs.

OMEGA is pleased to offer suggestions on the use of its various products. However, OMEGA neither assumes responsibility for any omissions or errors nor assumes liability for any damages that result from the use of its products in accordance with information provided by OMEGA, either verbal or written. OMEGA warrants only that the parts manufactured by the company will be as specified and free of defects. OMEGA MAKES NO OTHER WARRANTIES OR REPRESENTATIONS OF ANY KIND WHATSOEVER, EXPRESSED OR IMPLIED, EXCEPT THAT OF TITLE, AND ALL IMPLIED WARRANTIES INCLUDING ANY WARRANTY OF MERCHANTABILITY AND FITNESS FOR A PARTICULAR PURPOSE ARE HEREBY DISCLAIMED. LIMITATION OF LIABILITY: The remedies of purchaser set forth herein are exclusive, and the total liability of OMEGA with respect to this order, whether based on contract, warranty, negligence, indemnification, strict liability or otherwise, shall not exceed the purchase price of the component upon which liability is based. In no event shall OMEGA be liable for consequential, incidental or special damages.

CONDITIONS: Equipment sold by OMEGA is not intended to be used, nor shall it be used: (1) as a "Basic Component" under 10 CFR 21 (NRC), used in or with any nuclear installation or activity; or (2) in medical applications or used on humans. Should any Product(s) be used in or with any nuclear installation or activity, medical application, used on humans, or misused in any way, OMEGA assumes no responsibility as set forth in our basic WARRANTY/DISCLAIMER language, and, additionally, purchaser will indemnify OMEGA and hold OMEGA harmless from any liability or damage whatsoever arising out of the use of the Product(s) in such a manner.

RETURN REQUESTS/INQUIRIES

Direct all warranty and repair requests/inquiries to the OMEGA Customer Service Department. BEFORE RETURNING ANY PRODUCT(S) TO OMEGA, PURCHASER MUST OBTAIN AN AUTHORIZED RETURN (AR) NUMBER FROM OMEGA'S CUSTOMER SERVICE DEPARTMENT (IN ORDER TO AVOID PROCESSING DELAYS). The assigned AR number should then be marked on the outside of the return package and on any correspondence.

The purchaser is responsible for shipping charges, freight, insurance and proper packaging to prevent breakage in transit.

FOR **WARRANTY** RETURNS, please have the following information available BEFORE contacting OMEGA:

1. Purchase Order number under which the product was PURCHASED,
2. Model and serial number of the product under warranty, and
3. Repair instructions and/or specific problems relative to the product.

FOR **NON-WARRANTY** REPAIRS, consult OMEGA for current repair charges. Have the following information available BEFORE contacting OMEGA:

1. Purchase Order number to cover the COST of the repair,
2. Model and serial number of the product, and
3. Repair instructions and/or specific problems relative to the product.

OMEGA's policy is to make running changes, not model changes, whenever an improvement is possible. This affords our customers the latest in technology and engineering.

OMEGA is a registered trademark of OMEGA ENGINEERING, INC.

© Copyright 2014 OMEGA ENGINEERING, INC. All rights reserved. This document may not be copied, photocopied, reproduced, translated, or reduced to any electronic medium or machine-readable form, in whole or in part, without the prior written consent of OMEGA ENGINEERING, INC.

Where Do I Find Everything I Need for Process Measurement and Control? **OMEGA...Of Course!** *Shop online at omega.comSM*

TEMPERATURE

- Thermocouple, RTD & Thermistor Probes, Connectors, Panels & Assemblies
- Wire: Thermocouple, RTD & Thermistor
- Calibrators & Ice Point References
- Recorders, Controllers & Process Monitors
- Infrared Pyrometers

PRESSURE, STRAIN AND FORCE

- Transducers & Strain Gages
- Load Cells & Pressure Gages
- Displacement Transducers
- Instrumentation & Accessories

FLOW/LEVEL

- Rotameters, Gas Mass Flowmeters & Flow Computers
- Air Velocity Indicators
- Turbine / Paddlewheel Systems
- Totalizers & Batch Controllers

pH/CONDUCTIVITY

- pH Electrodes, Testers & Accessories
- Benchtop / Laboratory Meters
- Controllers, Calibrators, Simulators & Pumps
- Industrial pH & Conductivity Equipment

DATA ACQUISITION

- Data Acquisition & Engineering Software
- Communications-Based Acquisition Systems
- Plug-in Cards for Apple, IBM & Compatibles
- Data Logging Systems
- Recorders, Printers & Plotters

HEATERS

- Heating Cable
- Cartridge & Strip Heaters
- Immersion & Band Heaters
- Flexible Heaters
- Laboratory Heaters

ENVIRONMENTAL MONITORING AND CONTROL

- Metering & Control Instrumentation
- Refractometers
- Pumps & Tubing
- Air, Soil & Water Monitors
- Industrial Water & Wastewater Treatment
- pH, Conductivity & Dissolved Oxygen Instruments