



# Elektrotechnik Karl-Heinz Mauz GmbH

**LSM-104F/SQ** (Artikel-Nr. 130050)

**EKULIT**

## SPECIFICATIONS:

TYPE	UNIT	LSM-104F/SQ
Impedance	$\Omega$	$8 \pm 15\%$
Power (Nominal)	W	3
Power (Maximum)	W	5
Resonant Frequency	Hz	$150 \pm 20\%$
Sound Pressure Level	dB	$90 \pm 3$
Frequency Range	Hz	Fo~8.000
Operating Temperature	$^{\circ}\text{C}$	-20~+60
Storage Temperature	$^{\circ}\text{C}$	-30~+70

## DIMENSIONS :

(Unit: mm)

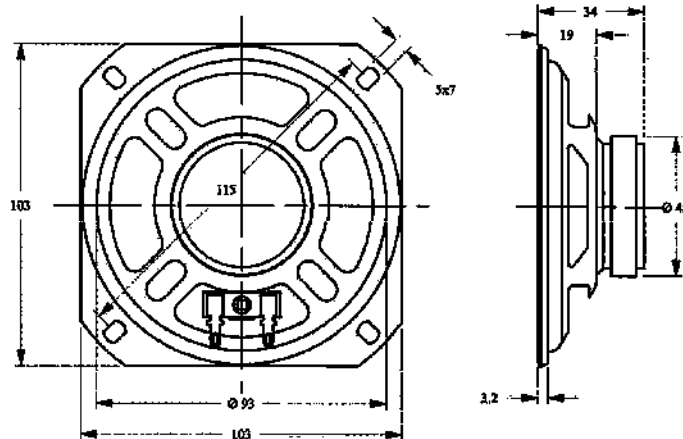

## Frequency response:

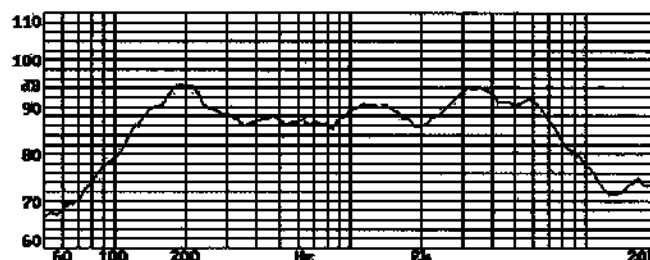

Adresse: Felix-Wankel-Str. 35 • 73760 Ostfildern/Nellingen

Tel: +49-711/3414023

Fax: +49-711/3414024

E-mail: [info@ekulit.de](mailto:info@ekulit.de) Web site: [www.EKULIT.de](http://www.EKULIT.de)