

## Variations

### Footprint Configuration

#### Four-Contact, Six-Position Unshielded

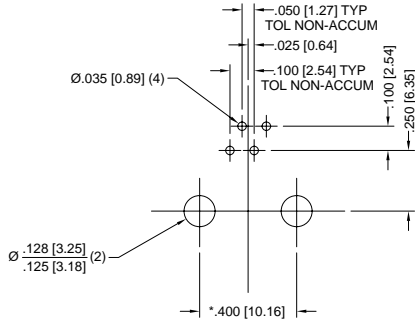

### Flange Options

#### No Flange (NF)

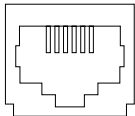

#### Panel Stop (FLS)

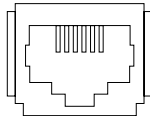

### Keying Option

#### OST (MMJ)

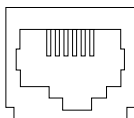

#### Four-Contact, Four-Position Unshielded

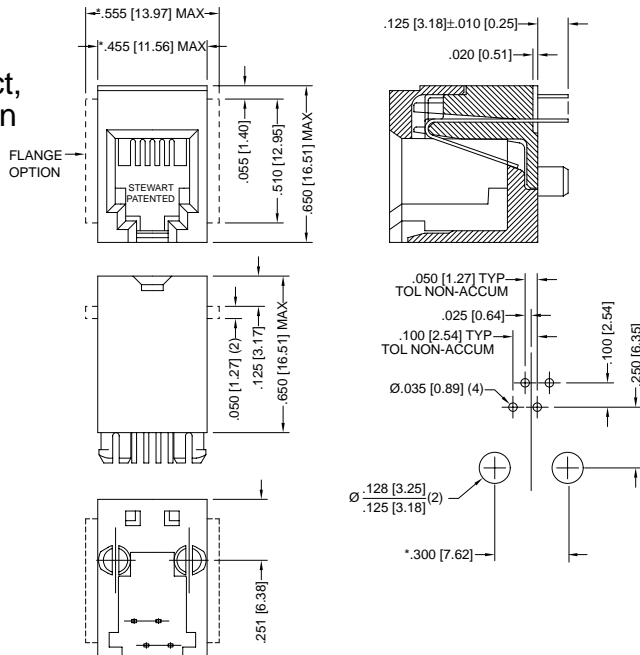

#### Six-Contact, Six-Position Unshielded

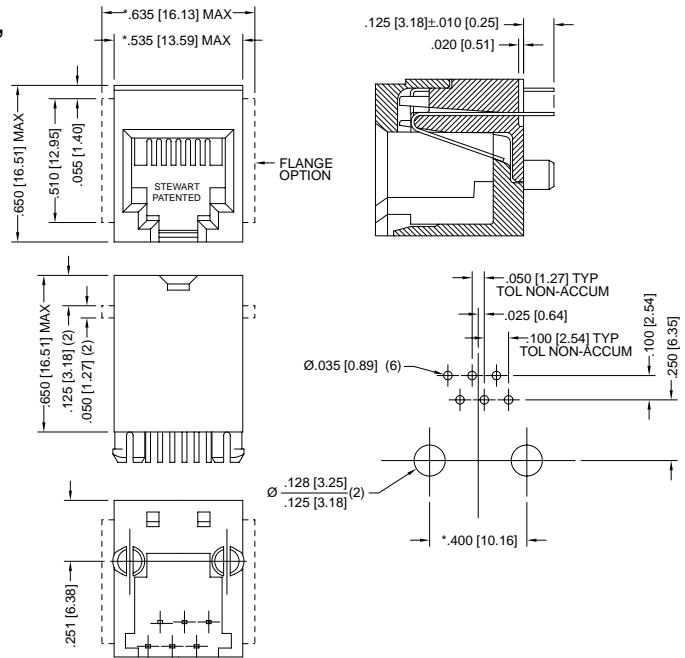

\*Dimension is central about center line.

## Quick Reference Chart

Description		Options			
Series	Contacts Inserted	Contact Positions	Flange Options		Keying Options
			FLS	NF	OST (MMJ)
65	4	4	●	●	
65	4	6	●	●	●
65	6	6	●	●	●

<sup>1</sup>Typical applications.

Note: Configurations shown are the most common for typical applications.

For availability of other configurations not listed, consult Stewart.

All dimensions are in inches with metric values in brackets.

# PC-Mount, Modular Jacks

• Unshielded • Vertical

# 65 Series

## Variations

### Ten-Contact, Ten-Position Unshielded

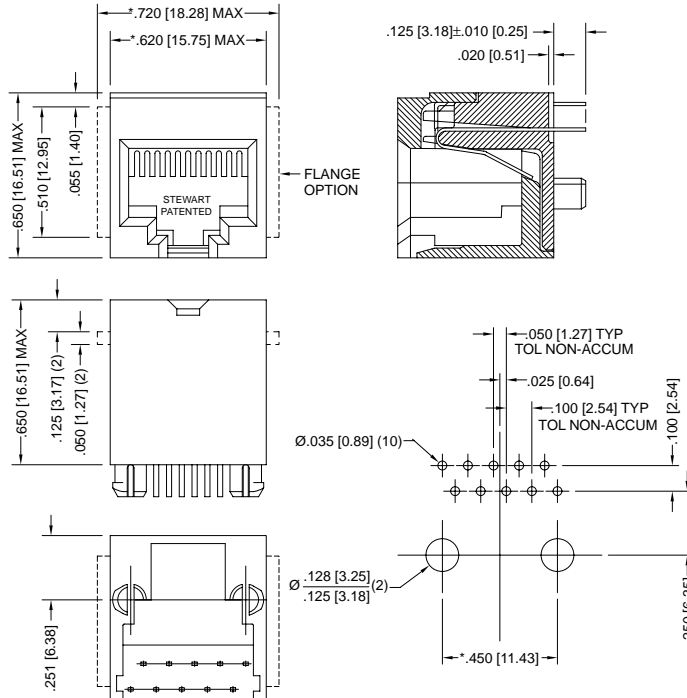

\*Dimension is central about center line.

### Quick Reference Chart

Description				Options				
Series	Contacts Inserted	Contact Positions	Flange Options		Keying Options			
			FLS	NF	K1	K2	RMK	
RJ-45 <sup>1</sup>	65	04	10	●	●	●	●	●
	65	08	10	●	●	●	●	●
	65	10	10	●	●	●	●	●

<sup>1</sup>Typical applications.

Note: Configurations shown are the most common for typical applications. For availability of other configurations not listed, consult Stewart.

### How to Order

EXAMPLE: SS - 65 - 6 - 6 - FLS - OST - 50 - X

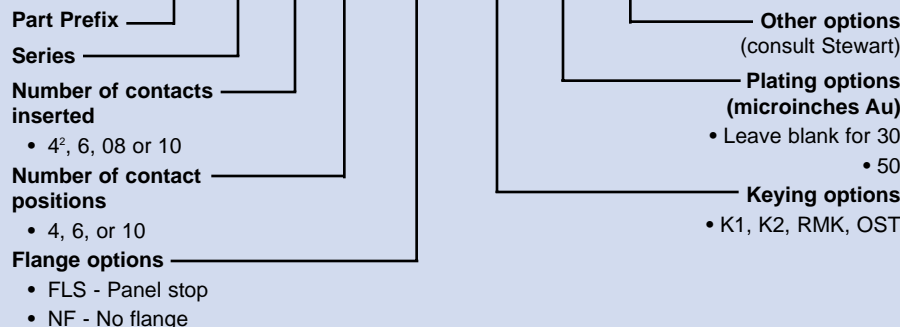

<sup>2</sup>Use 04 when referring to four-contact, ten-position jacks. All dimensions are in inches with metric values in brackets.

### Footprint Configurations

#### Four-Contact, Ten-Position Unshielded

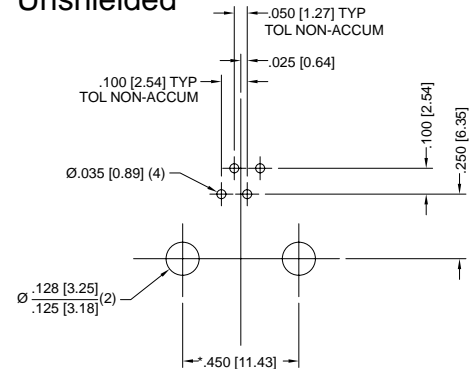

#### Eight-Contact, Ten-Position Unshielded

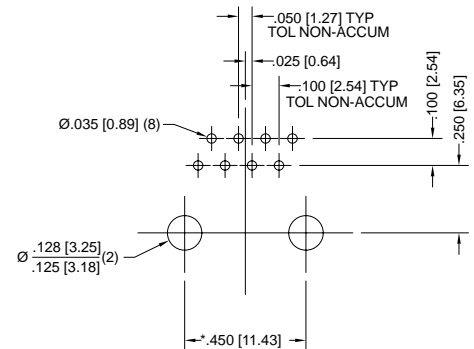

### Flange Options

No Flange (NF)

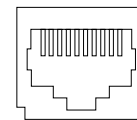

Panel Stop (FLS)

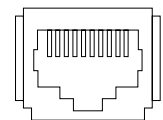

### Keying Options

K1-Key

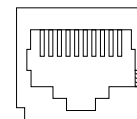

K2-Key

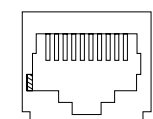

RMK-Key

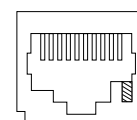

Cutout

## Variations

### Footprint Configurations

#### Four-Contact, Ten-Position Unshielded (A)

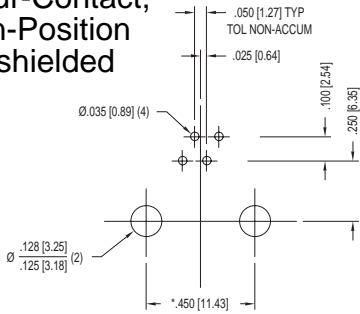

#### Six-Contact, Ten-Position Unshielded (A)

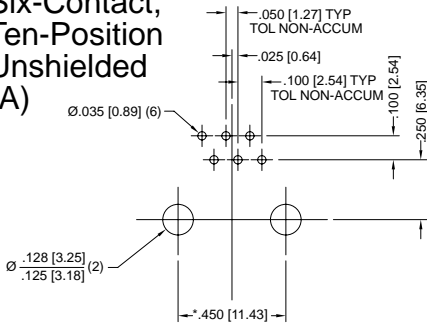

#### Eight-Contact, Ten-Position Unshielded (A)

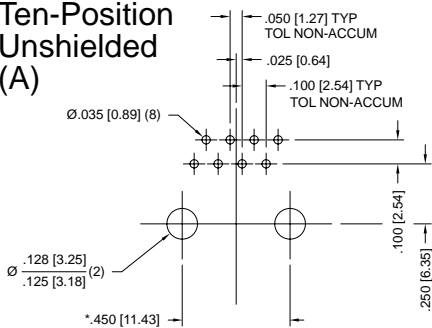

### Keying Options

#### K1-Key

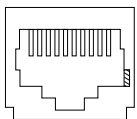

#### K2-Key

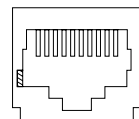

#### RMK-Key

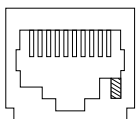

### Ten-Contact, Ten-Position Unshielded Radiused Edges (A)

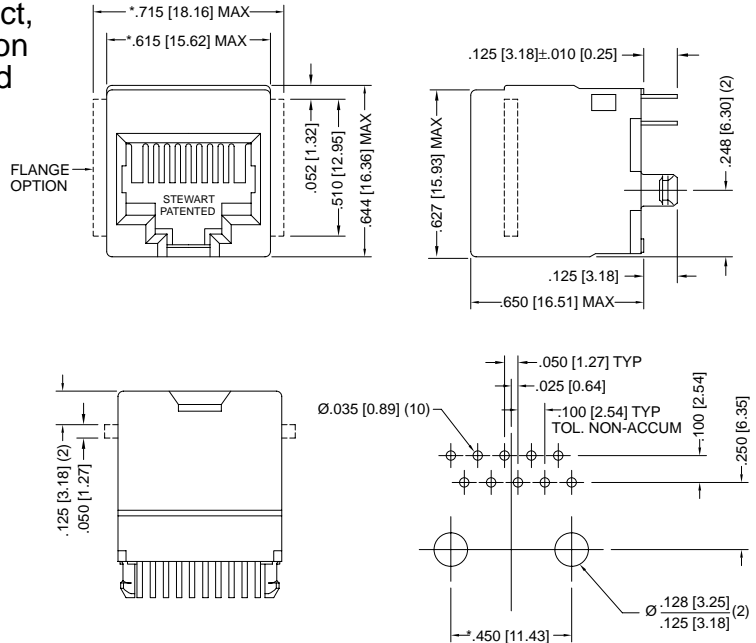

\*Dimension is central about center line.

## Quick Reference Chart

Description					Options				
Series	Contacts Inserted	Contact Positions	Radiused Edges (A)	Flange Options		Keying Options			
				FLS	NF	K1	K2	RMK	
RJ-45 <sup>1</sup>	65	04	10	●	●	●	●	●	
	65	06	10	●	●	●	●	●	
	65	08	10	●	●	●	●	●	
	65	10	10	●	●	●	●	●	

<sup>1</sup>Typical applications.

Note: Configurations shown are the most common for typical applications. For availability of other configurations not listed, consult Stewart.

## How to Order

EXAMPLE: SS - 65 10 10 - A - FLS - K1 - 50 - X

Part Prefix  
Series  
Number of contacts inserted  
• 04, 06, 08 or 10  
Number of contact positions  
• 10  
Radiused Edges

Other options (consult Stewart)  
Plating options (microinches Au)  
• Leave blank for 30  
• 50  
Keying options  
• K1, K2, RMK  
Flange options  
• FLS - Panel stop  
• NF - No flange

All dimensions are in inches with metric values in brackets.