

1 2 3 4 5 6 7 8

| REVISIONS | | |
|-----------|------|------------------------------|
| ISS | ZONE | DESCRIPTION\PER REQUEST\DATE |
| | | |

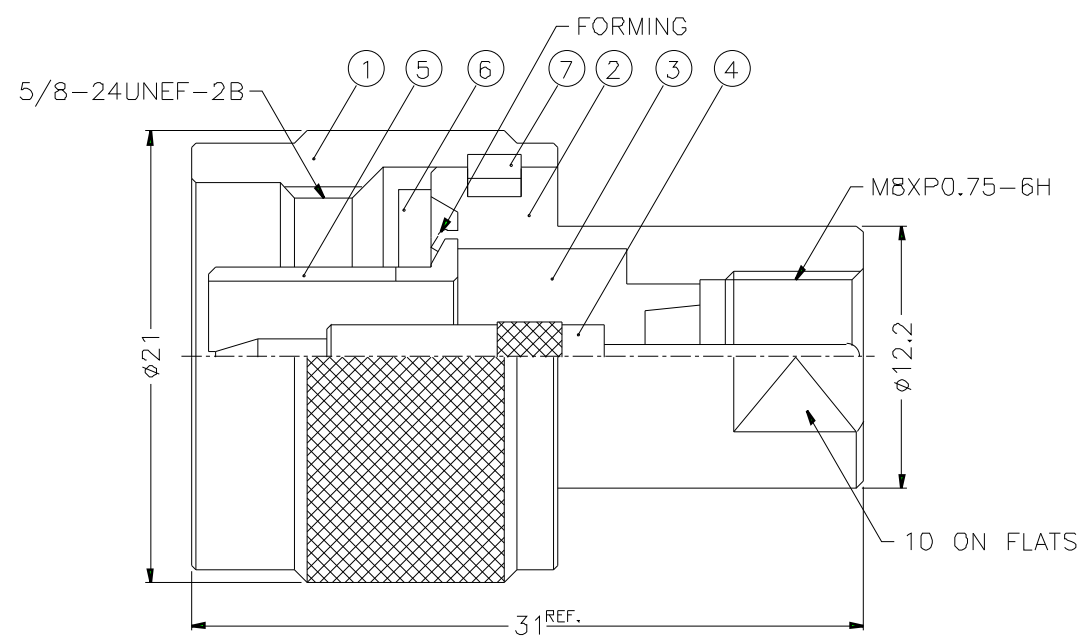

NOTES: FINISH (PLATING THICKNESS IN MICRO-INCHES)
 1. BRASS PER QQ-B-626
 2. NICKEL PL. 100 MIN. THICK OVER COPPER STRIKE
 3. SILVER PL. 200 MIN. THICK OVER COPPER STRIKE
 4. TEFLON MIL-P-19468

| | | | | | | | | | |
|-----|---------------|----------|---------|------|-----------------|--|---------------------------------|----------------|---|
| 7 | RETAINER RING | SUS 304 | NATURAL | 1 | N5000-7-C | DIMENSIONS ARE IN MILLIMETERS UNLESS OTHERWISE SPECIFIED TOLERANCES 0.5-6 = ±0.2 6-30 = ±0.4 30-120 = ±0.6 120-315 = ±1 315-1000 = ±1.6 1000-2000 = ±2.4 | PART NO. FME2071N1-NTS-50 | | <h1>Amphenol</h1> <p>N MALE TO FME MALE ADAPTOR</p> |
| 6 | GASKET | SILICONE | RED | 1 | GS-156/8X15 | | APPROVED | DATE 10-11-01' | |
| 5 | CONTACT BODY | NOTE 1 | NOTE 2 | 1 | N5000-5 | | CHECKED | DATE 10-11-01' | |
| 4 | CONTACT PIN | NOTE 1 | NOTE 3 | 1 | FME2071N1-4 | | DRAWN | DATE 10-11-01' | |
| 3 | INSULATOR | NOTE 4 | NATURAL | 1 | FME2071N1-3T-50 | | DRAWING NO. KJ-FME2071N1-NTS-50 | | |
| 2 | BODY | NOTE 1 | NOTE 2 | 1 | FME2071N1-2 | ITEM NO. | | A | |
| 1 | SHELL | NOTE 1 | NOTE 2 | 1 | N5000-1-B | FILE NO. | | | |
| NO. | DESCRIPTION | MATERIAL | FINISH | Q'TY | DRAWING NO. | SCALE 3/1 | ISSUE A | | |

1 2 3 4 5 6 7 8