

Drawings / Zeichnungen:  
InnoTech Atira

Technik für Möbel

  
**Hettich**

Model / Ausführung	Drawer / Schubkasten
Profile height / Zargenhöhe	70 mm
Nominal length / Nennlänge	420 mm
Cabinet side panel thickness / Korpuseitendicke	16 / 18 / 19 mm

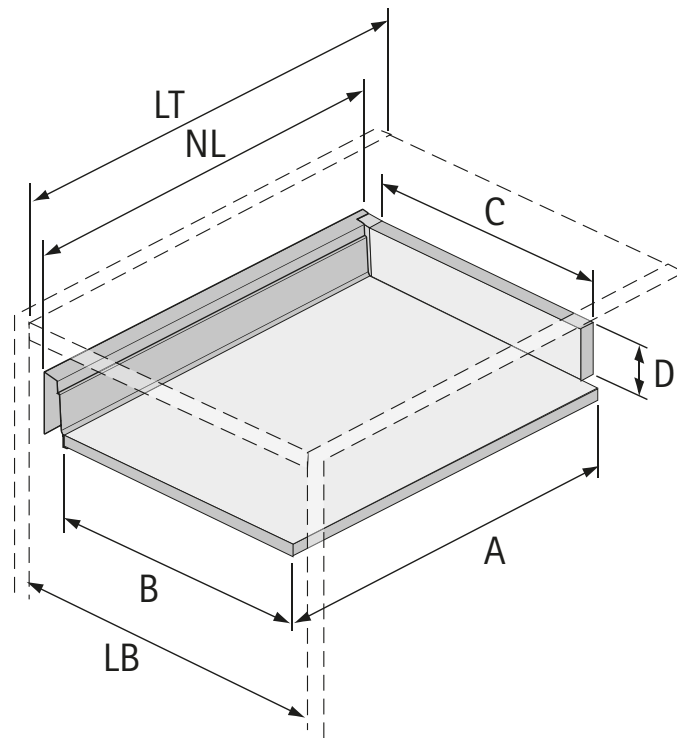

Measurement / Maß	Steel rear panel / Stahlrückwand	Wooden rear panel / Holzurückwand	Alu rear panel / Aluminiumrückwand
A	417	430	417
B	$LB - 2x EB - 51,5$	$LB - 2x EB - 51,5$	$LB - 2x EB - 51,5$
C	-	$LB - 2x EB - 63$	$LB - 2x EB - 63$
D	-	65,5	

Note: For Push to open applications NL 420 the minimum cabinet depth increases by 26 mm.

Achtung: Bei der Verwendung von Push to open NL 420 erhöht sich die Mindestkorpustiefe um 26 mm.

Frontview / Frontansicht 16 mm Quadro 25

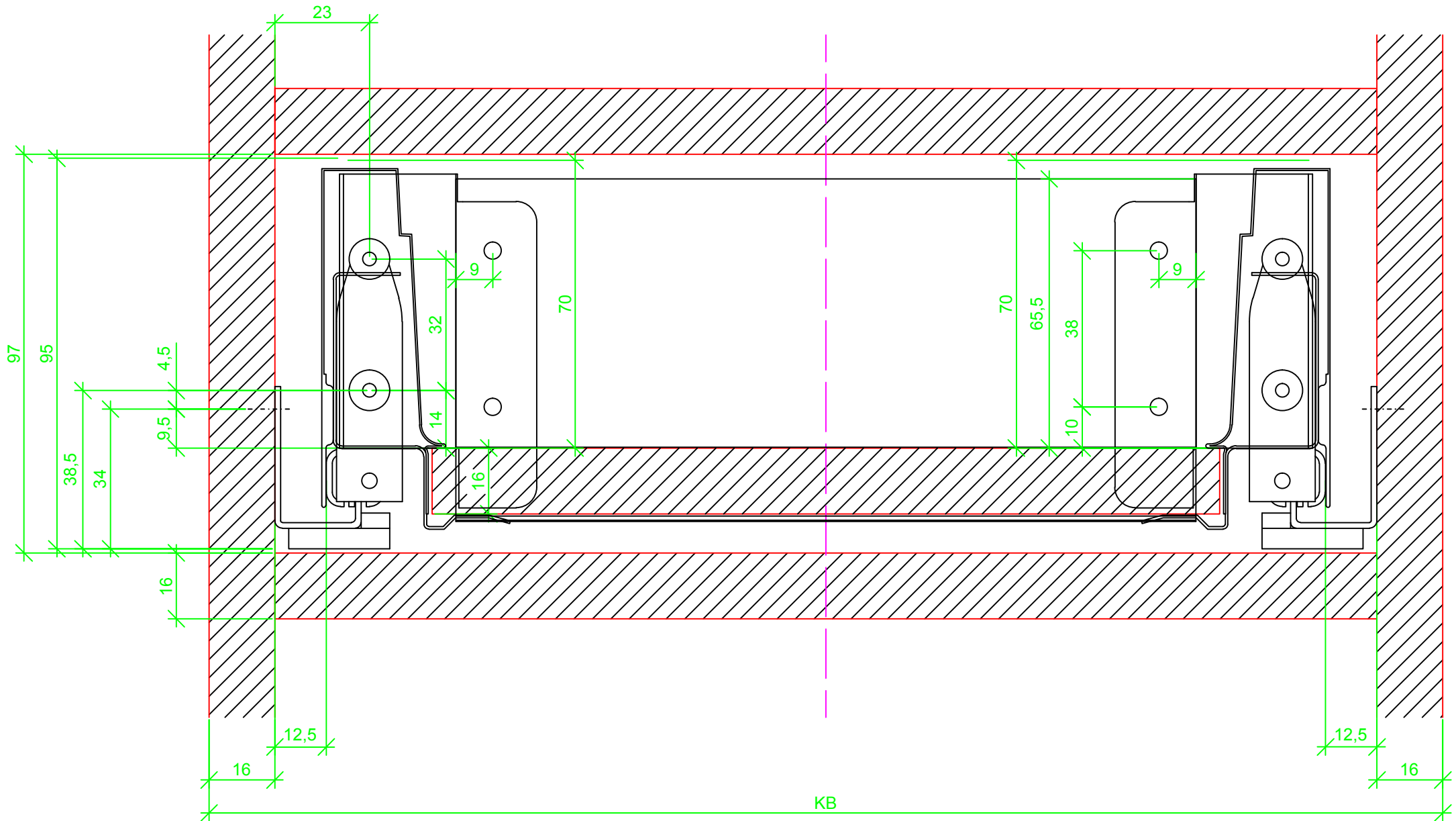

Frontview / Frontansicht 16 mm Quadro V6

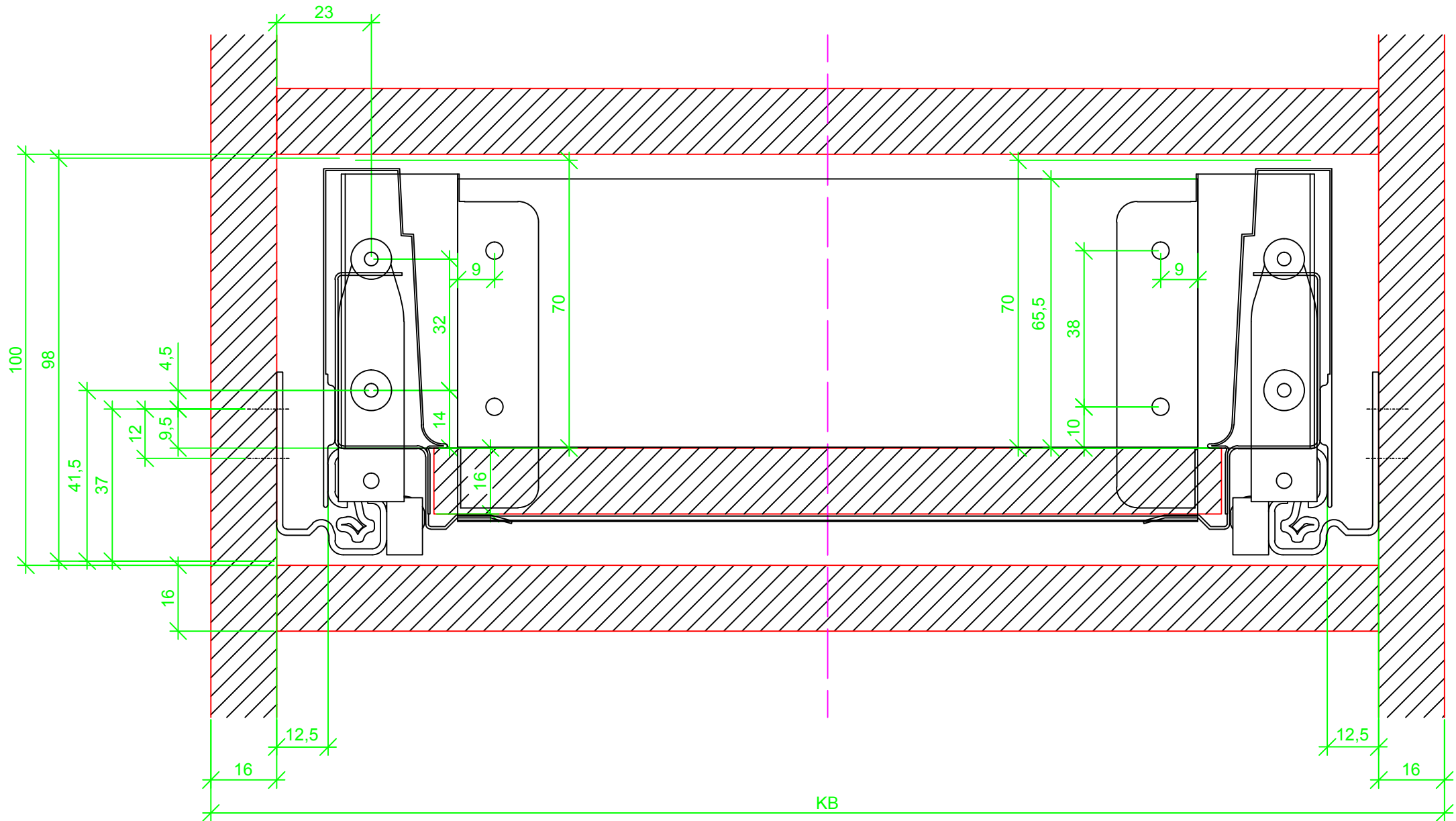

Frontview / Frontansicht 16 mm Quadro V6+

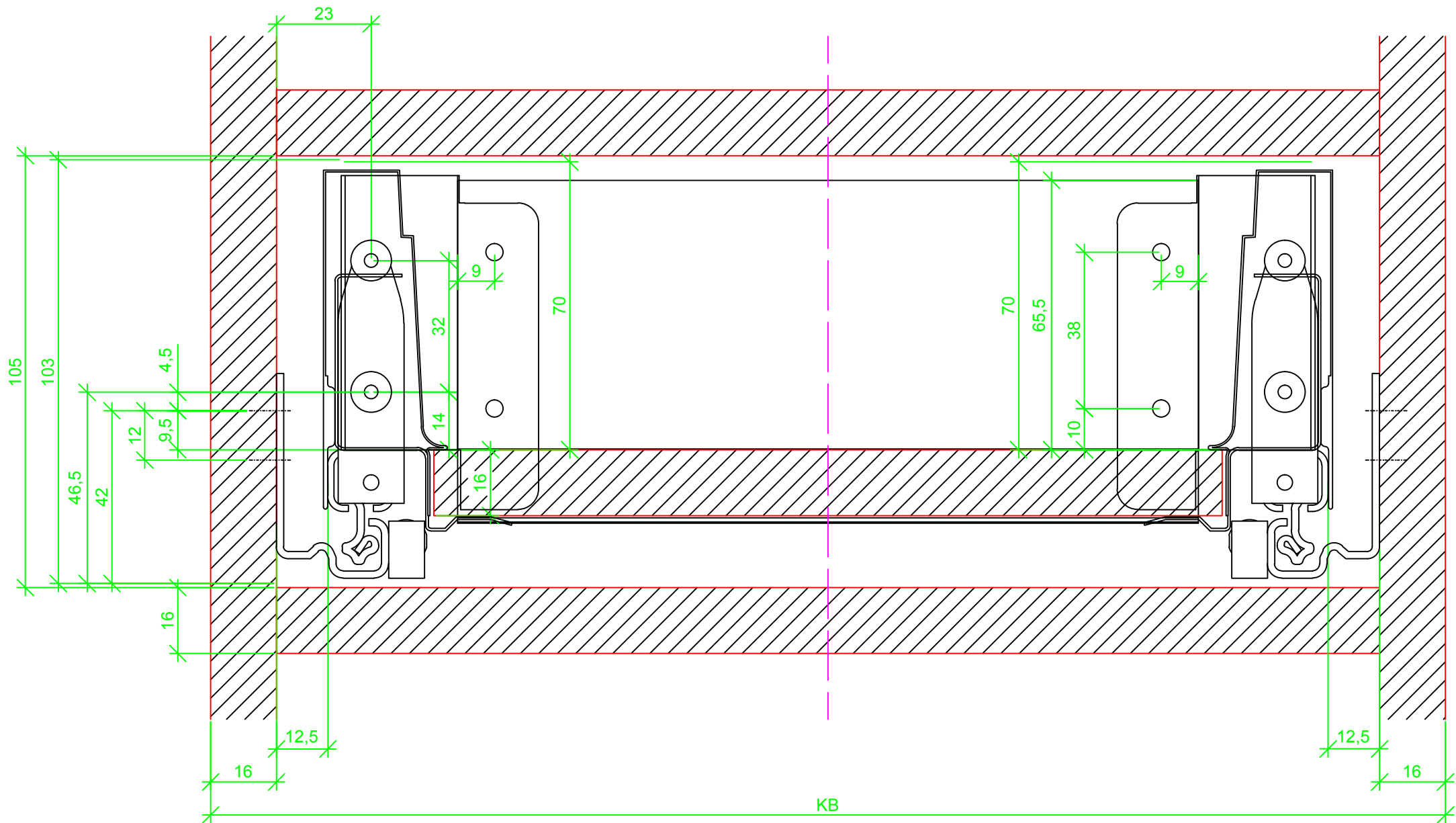

Frontview / Frontansicht 18 mm Quadro 25

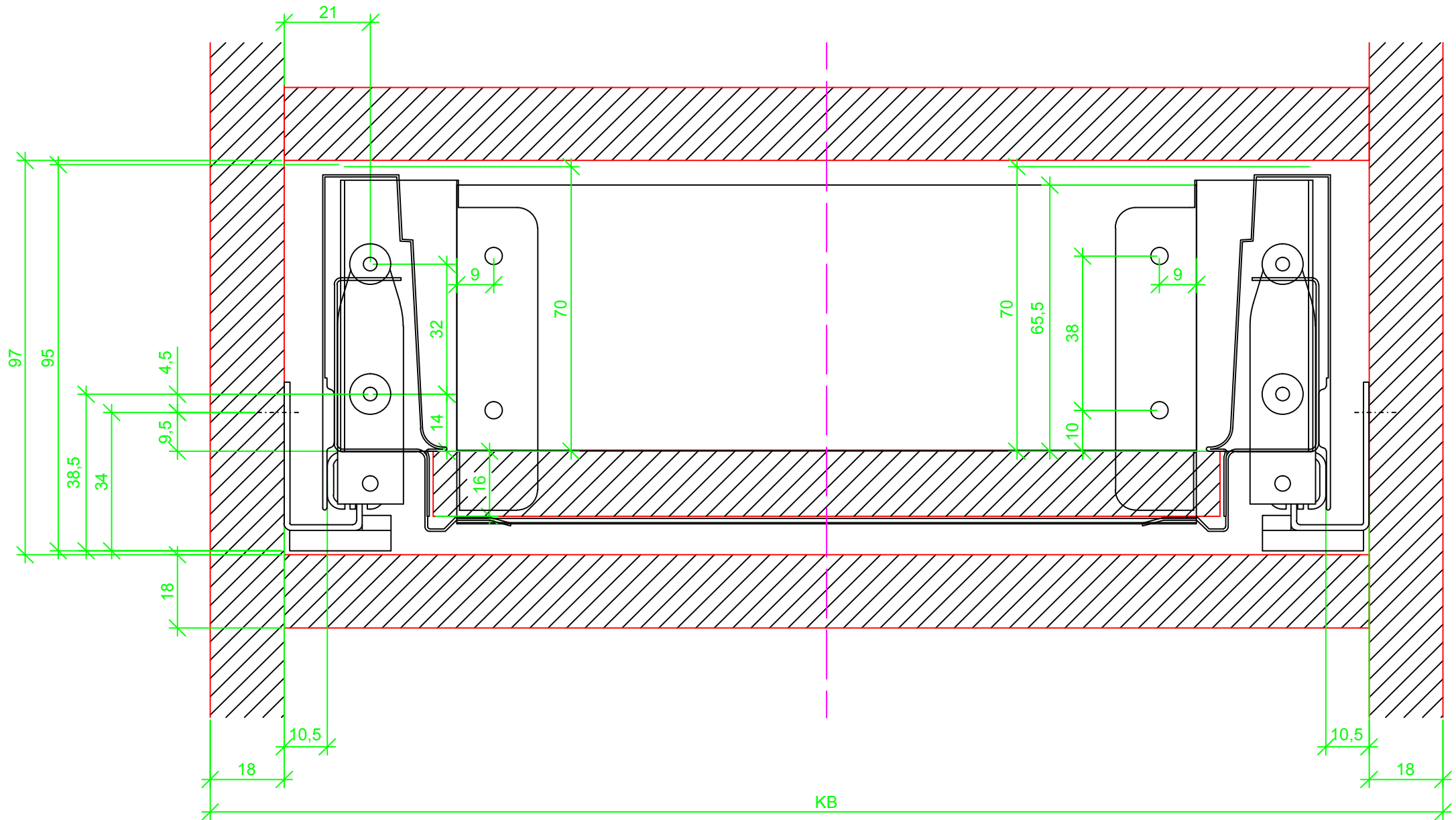



# Frontview / Frontansicht 18 mm Quadro V6+

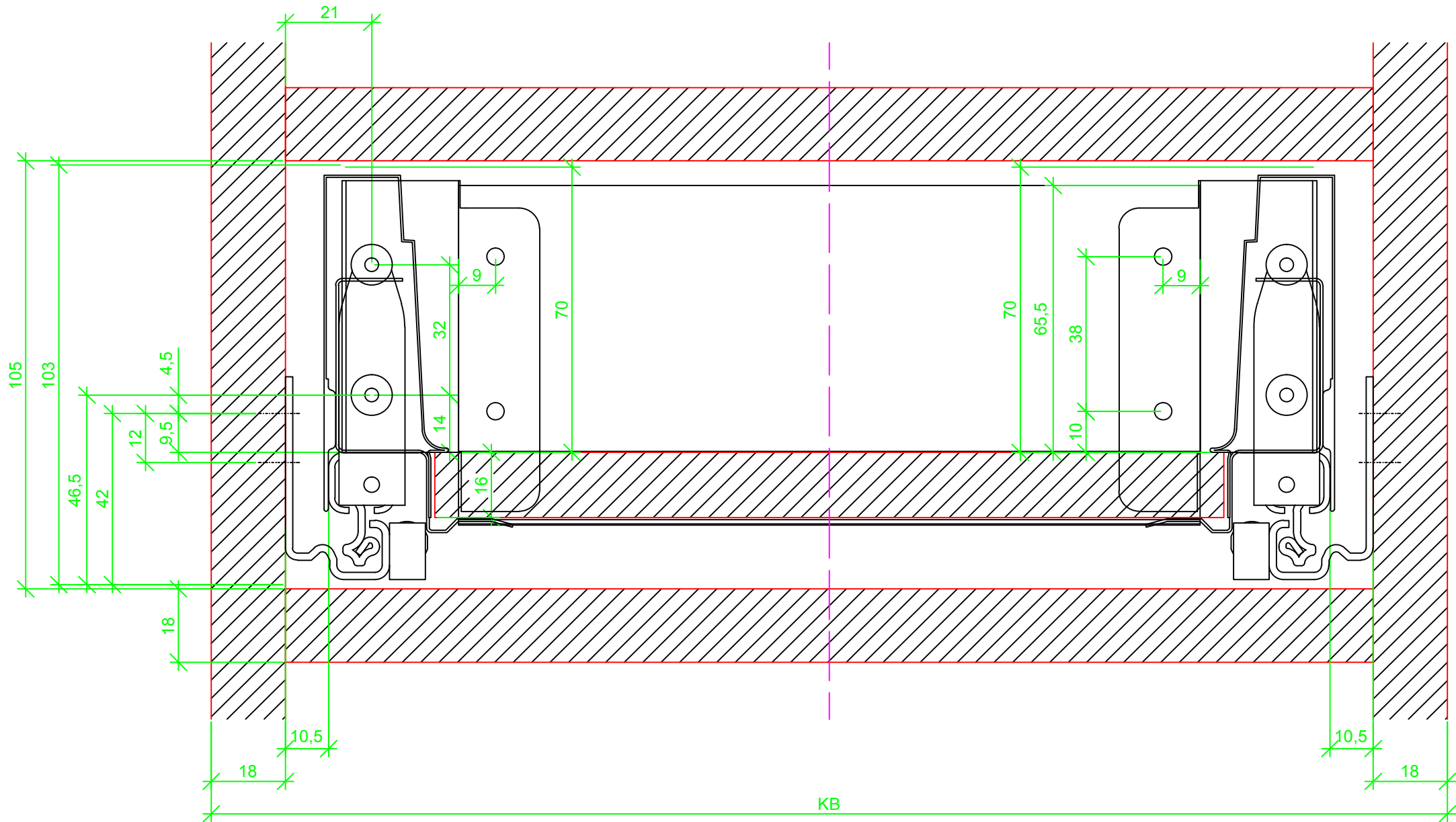



Frontview / Frontansicht 19 mm Quadro 25

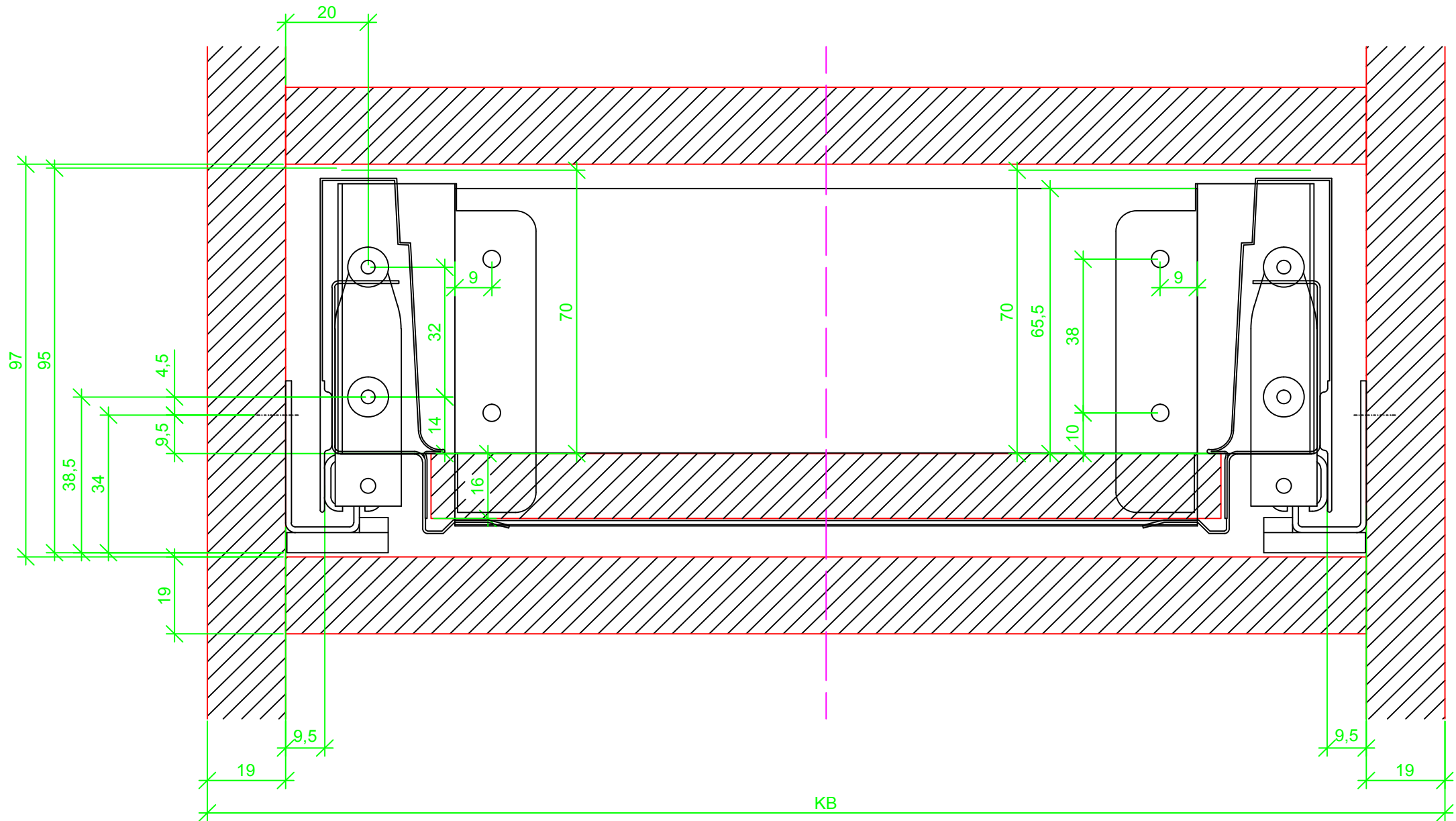

Frontview / Frontansicht 19 mm Quadro V6

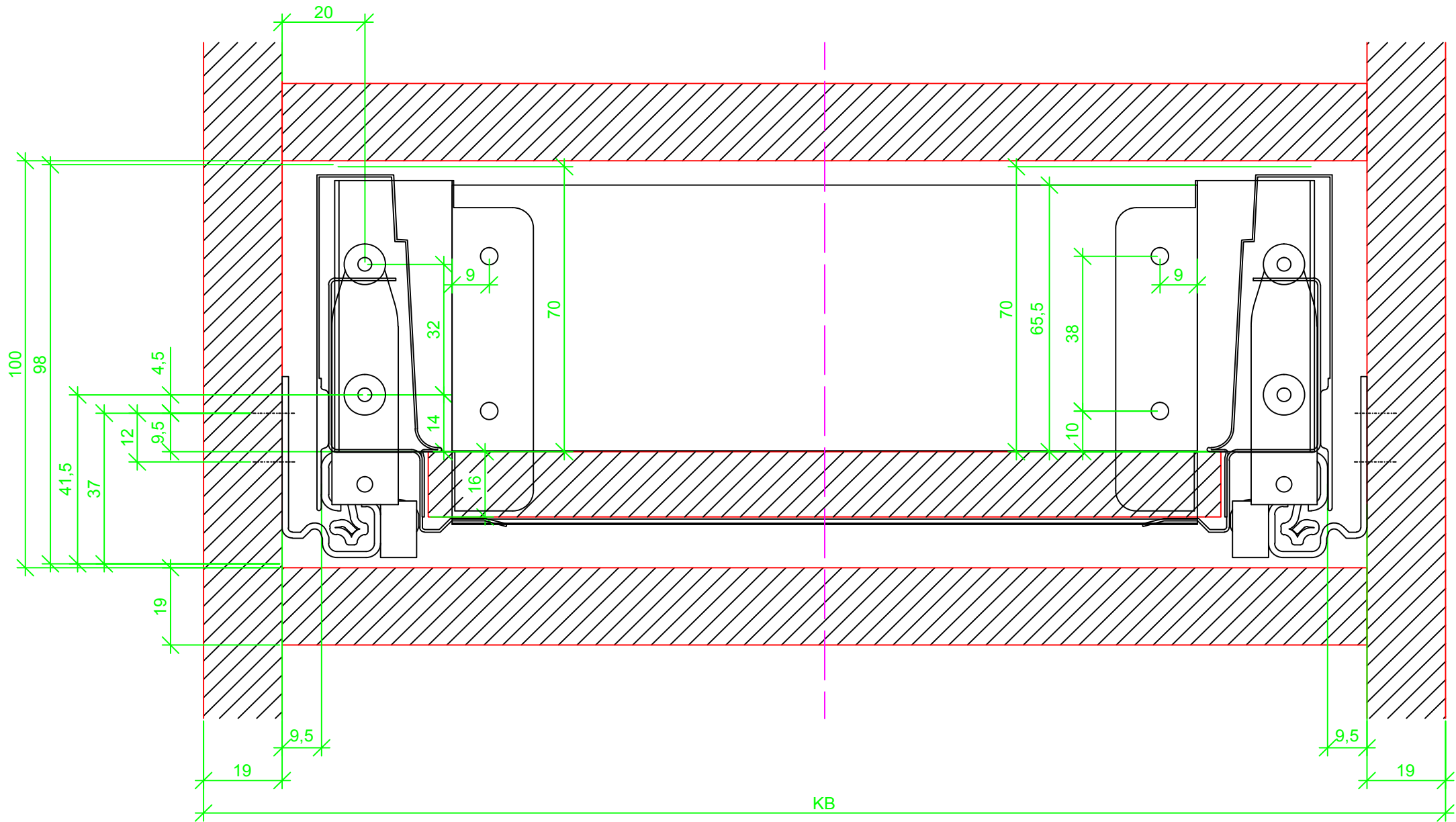

Frontview / Frontansicht 19 mm Quadro V6+

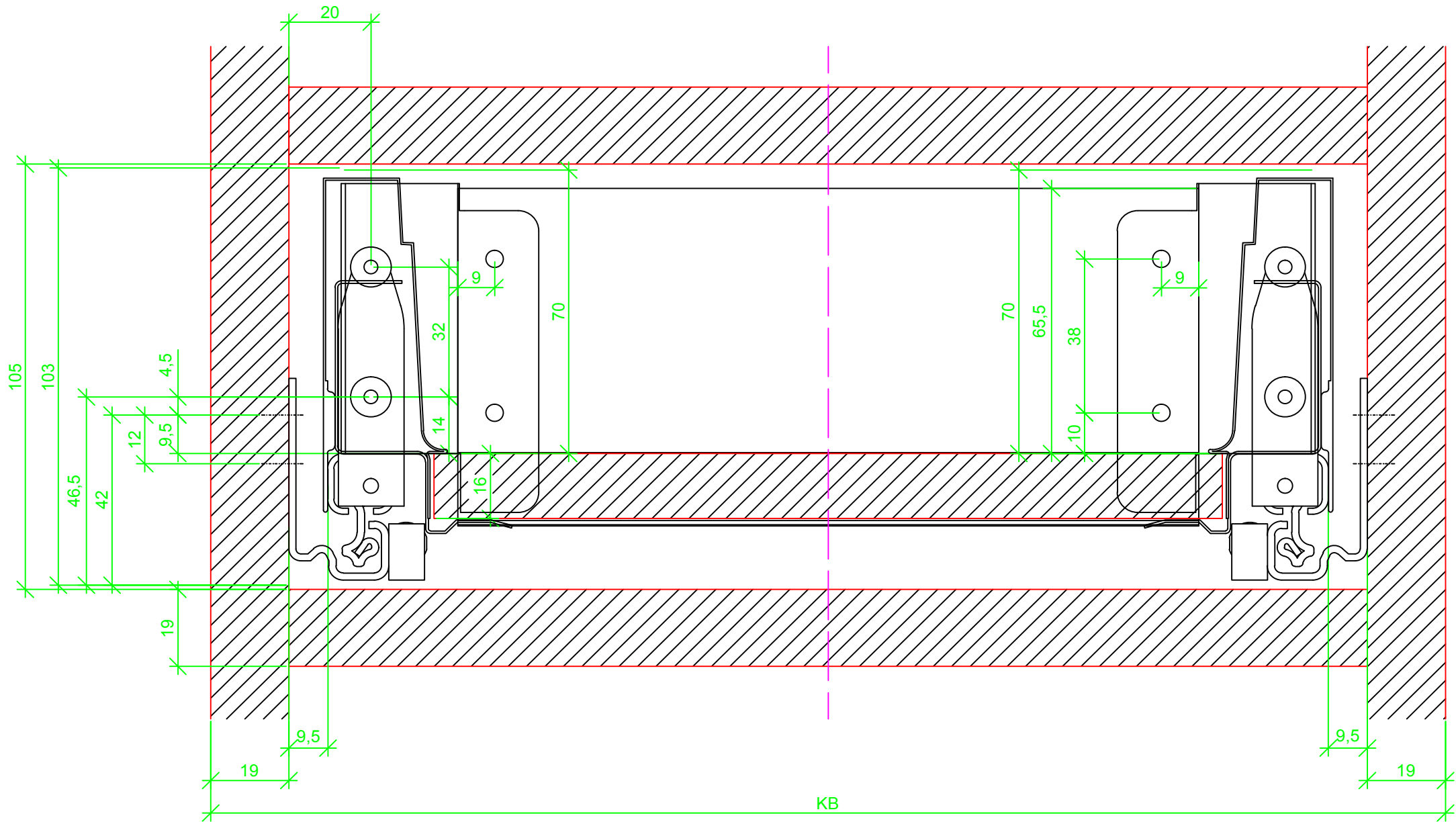

# Sideview / Seitenansicht Quadro 25

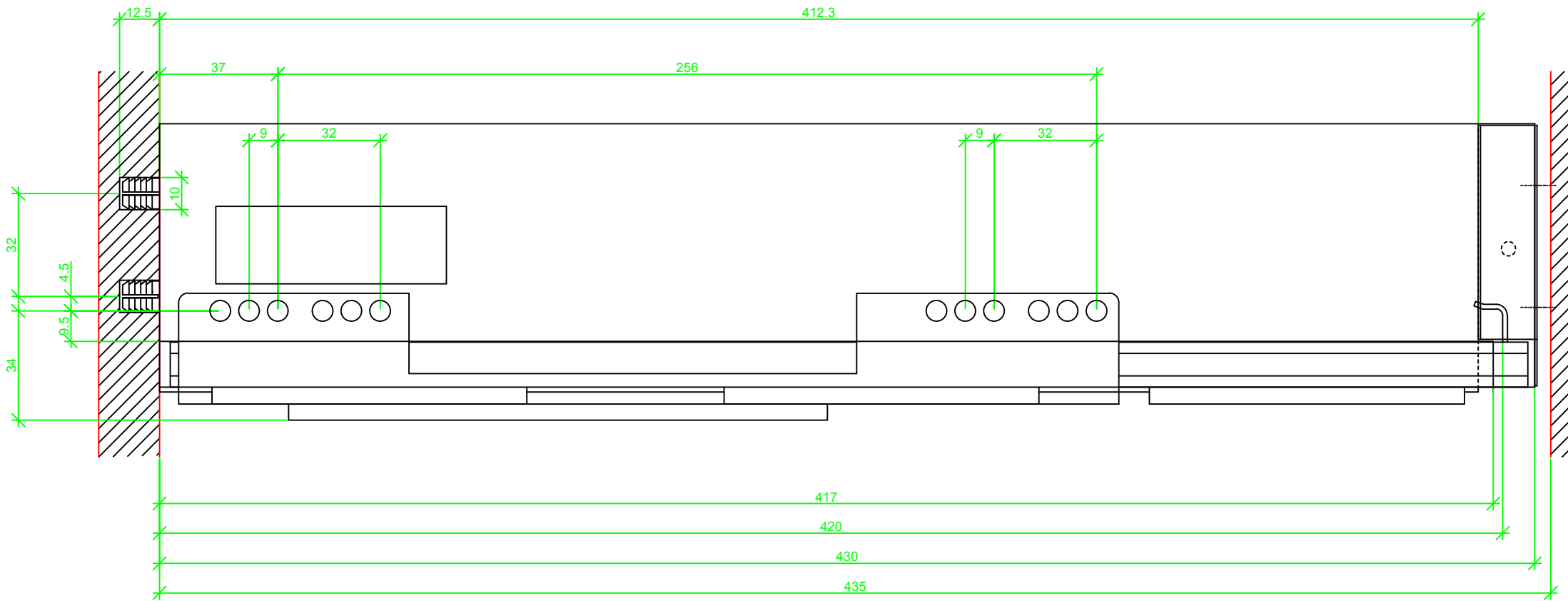

# Sideview / Seitenansicht Quadro V6

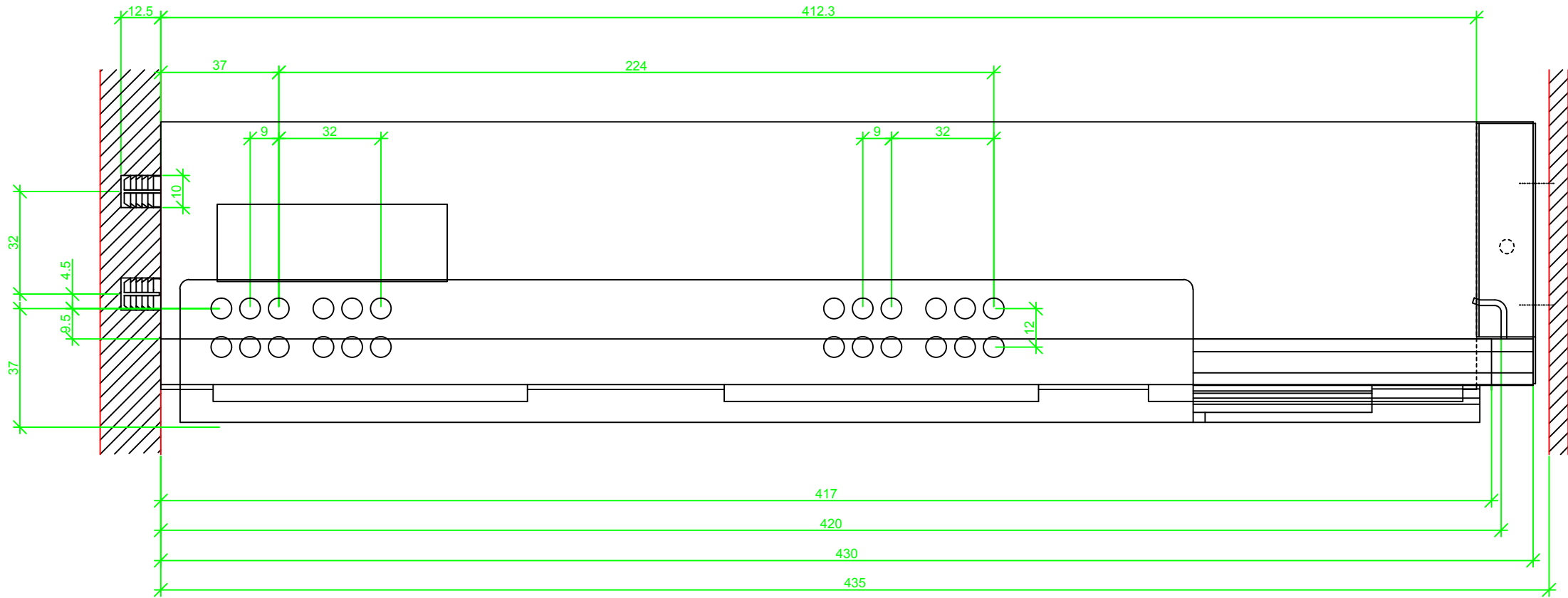

# Sideview / Seitenansicht Quadro V6+

