

PFH-T

COMPACT FAN HEATER WITH INTEGRATED THERMOSTAT

200–1200 W

- high power to size ratio ⇒ small, compact design
- wide range of heating capacities 200-1200 W in one housing
- fast heating due to PTC technology
- wall or DIN rail mounting
- low surface temperature
- finger guard at inlet and outlet
- integrated adjustable thermostat



PRODUCT	PFH-T 200	PFH-T 300	PFH-T 400	PFH-T 500	
ARTICLE NO.	17020710034	17030710034	17040710034	17050710034	Unit

DATA					
Heating performance (Ta = +10 °C)	200	300	400	500	W
Max. starting current	9	12	15	20	A
Max. pre fuse T	6		10		
Max. surface temperature	55				°C
Volumetric air flow	50				m³/h

PRODUCT	PFH-T 650	PFH-T 800	PFH-T 1000	PFH-T 1200	
ARTICLE NO.	17065710034	17080710034	17099710034	17099810034	Unit

DATA					
Heating performance (Ta = +10 °C)	650	800	1000	1200	W
Max. starting current	25	31	25	31	A
Max. pre fuse T	10				
Max. surface temperature	70				°C
Operating temperature	-40 ... +70				
System of protection for intended purpose of use	IP 20				V
Rated voltage ¹ ±10 %	AC 50 60 Hz				
	230				
Functional range	207 – 258 V AC 50 60 Hz				
Protection class	II				g
Device construction	plastic UL 94V-0, black				
Type of mounting	snap fastening for 35 mm profile bars according to EN 60715 4 x M5 screws (not included)				
Type of connection	plug terminal connector				
Weight	760				

ACCESSORIES	ARTICLE NUMBER
Hygrostat	17207000000
Internal enclosure fan	18110000000

For additional models, options and voltages visit www.pfannenber.com or contact us directly.

¹ other voltages available on request

Dimensions

mm	PFH-T
X	88
Y	142
Z	139
A	129
B	142
C	147
D	88
E	5,5
F	6
G	35

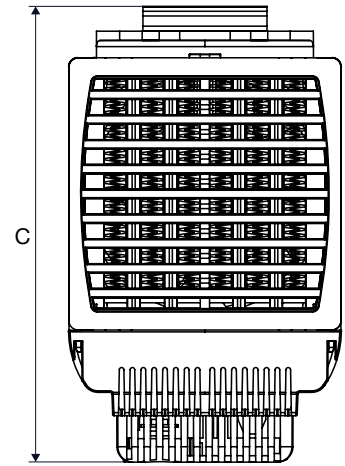
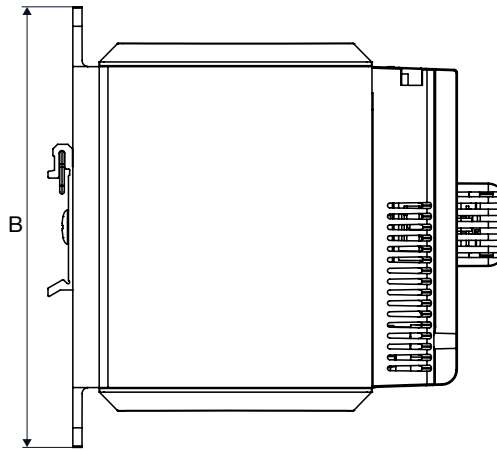
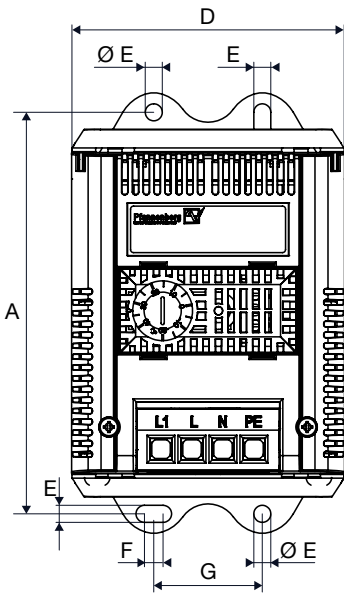
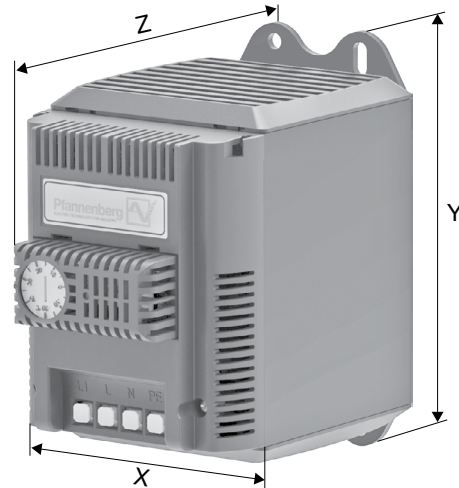

Schematics

Version 1

without internal thermostat

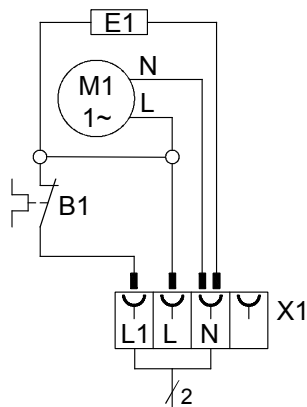

Version 2

with internal thermostat and external thermostat which control independent to each other

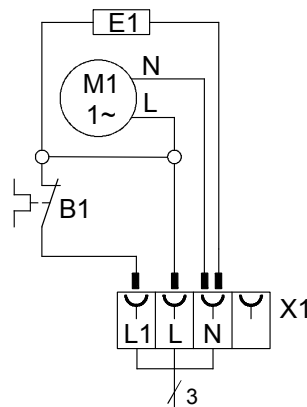

M1: fan
E1: PTC - heating element
X1: connection
B1: thermostat (optional)