

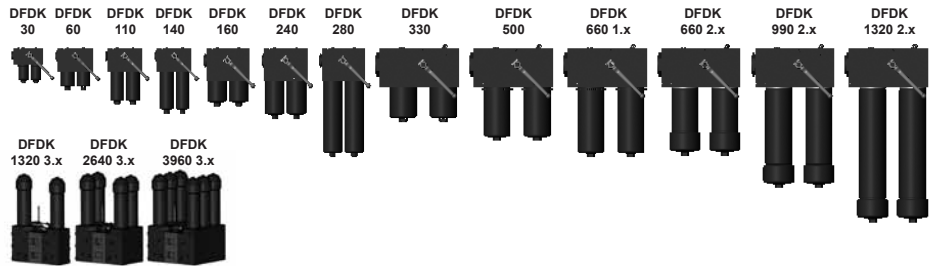

## Change-Over Pressure Filter DFDK up to 2500 l/min, up to 315 bar



### 1. TECHNICAL SPECIFICATIONS

#### 1.1 FILTER HOUSING

##### Construction

The filter housings are designed in accordance with international regulations. They consist of a filter head with screw-in filter bowls.

Standard equipment:

- ball change-over valve
- two-piece filter bowl for DFDK 990, 1320 (as an option for DFDK 660)
- connection for a clogging indicator
- drain screw with pressure relief
- pressure equalization line (for size DFDK 330 and above)

#### 1.2 FILTER ELEMENTS

HYDAC filter elements are validated and their quality is constantly monitored according to the following standards:

- ISO 2941, ISO 2942, ISO 2943, ISO 3724, ISO 3968, ISO 11170, ISO 16889

#### Contamination retention capacities in g

DFDK	Elements per side	Betamicon® (BN4HC)			
		3 µm	5 µm	10 µm	20 µm
30	1x0030 D	4.6	5.1	5.4	5.6
60	1x0060 D	6.5	7.3	7.8	8.0
110	1x0110 D	13.8	15.5	16.4	16.9
140	1x0140 D	18.1	20.3	21.5	22.2
160	1x0160 D	19.8	22.2	23.5	24.3
240	1x0240 D	32.3	36.3	38.4	39.6
280	1x0280 D	70.6	79.3	83.9	86.6
330	1x0330 D	47.2	53.1	56.1	57.9
500	1x0500 D	76.9	86.5	91.5	94.4
660	1x0660 D	102.2	114.9	121.5	125.4
990	1x0990 D	154.5	173.7	183.7	189.5
1320	1x1320 D	209.9	236.0	249.6	257.5
1320.3.X	1x1320 D	209.9	236.0	249.6	257.5
2640.3.X	2x1320 D	419.8	472.0	499.2	515.0
3960.3.X	3x1320 D	629.7	708.0	748.8	772.5

DFDK	Elements per side	Betamicon® (BH4HC)			
		3 µm	5 µm	10 µm	20 µm
30	1x0030 D	3.0	2.9	3.2	3.7
60	1x0060 D	4.6	4.5	5.0	5.7
110	1x0110 D	10.1	9.9	10.9	12.4
140	1x0140 D	13.3	13.0	14.3	16.3
160	1x0160 D	12.9	12.6	13.9	15.9
240	1x0240 D	21.6	21.1	23.2	26.5
280	1x0280 D	48.1	47.1	51.8	59.1
330	1x0330 D	34.6	33.9	37.2	42.5
500	1x0500 D	57.5	56.3	61.8	70.5
660	1x0660 D	76.8	75.2	82.6	94.3
990	1x0990 D	111.8	109.4	120.2	137.2
1320	1x1320 D	153.8	150.7	165.5	188.8
1320.3.X	1x1320 D	153.8	150.7	165.5	188.8
2640.3.X	2x1320 D	307.6	301.4	331.0	377.6
3960.3.X	3x1320 D	461.4	452.1	496.5	566.4

#### 1.3 FILTER SPECIFICATIONS

Nominal pressure	160 bar (DFDK with type code 3.X) 315 bar (DFDK with type code 1.X and 2.X)
Fatigue strength	At nominal pressure 10 <sup>6</sup> cycles from 0 to nominal pressure
Temperature range	-10 °C to +100 °C (-30 °C to -10 °C: p <sub>max</sub> = 157.5 bar)
Material of filter head	EN-GJS-400-15
Material of filter bowl	Steel
Type of clogging indicator	VD (differential pressure measurement up to 420 bar operating pressure)
Pressure setting of the clogging indicator	8 bar (others on request)

Filter elements are available with the following pressure stability values:

Betamicon® (BN4HC):	20 bar
Betamicon® (BH4HC):	210 bar
Wire mesh (W/HC,W):	20 bar
Stainless steel fibre (V):	210 bar

#### 1.4 SEALS

NBR (= Perbunan)

#### 1.5 INSTALLATION

As inline filter

#### 1.6 SPECIAL MODELS AND ACCESSORIES

Pressure equalization line  
DFDK 160 - 280

#### 1.7 SPARE PARTS

See Original Spare Parts List

#### 1.8 CERTIFICATES AND APPROVALS

On request

#### 1.9 COMPATIBILITY WITH HYDRAULIC FLUIDS ISO 2943

- Hydraulic oils H to HLPD DIN 51524
- Lubrication oils DIN 51517, API, ACEA, DIN 51515, ISO 6743
- Compressor oils DIN 51506
- Biodegradable operating fluids VDMA 24568 HETG, HEES, HEPG
- Fire-resistant fluids HFA, HFB, HFC and HFD
- Operating fluids with high water content (>50% water content) and CLP-oil on request

#### 1.10 IMPORTANT INFORMATION

- Filter housings must be earthed.
- When using electrical clogging indicators, the electrical power supply to the system must be switched off before removing the clogging indicator connector.

#### Symbol for hydraulic systems

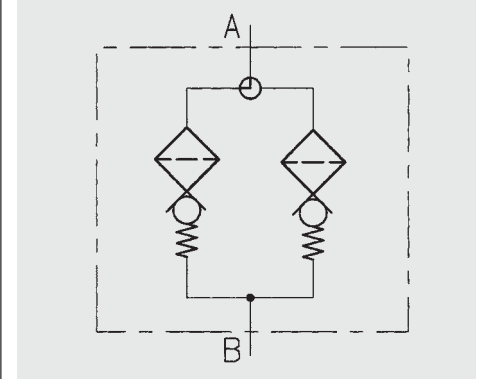

## 2. MODEL CODE (also order example)

DFDK BN/HC 160 Q A F 10 D 1 . X /-L24

### 2.1 COMPLETE FILTER

#### Filter type

DFDK

#### Filter material of element

BN/HC Betamicon® (BN4HC) V Stainless steel fibre  
 BH/HC Betamicon® (BH4HC) W/HC, W Wire mesh

#### Size of filter or element

DFDK: 30, 60, 110, 140, 160, 240, 280, 330, 500, 660, 990, 1320, 2640, 3960

#### Operating pressure

Q = 315 bar  
 K = 160 bar (only for DFDK 1320, 2640, 3960...3.x)

#### Type of change-over

A Ball

#### Type and size of connection

Type	Connection type	Filter size												
		30	60	110	140	160	240	280	330	500	660	990	1320	1320/2640/3960...3.x
B	G 1/2	•												
C	G 3/4		•	•	•									
F	G1 1/2					•	•	•						
L	SAE DN 50*								•	•	•	•	•	
M	SAE DN 65													•

\*DIN ISO 228 (6000 PSI)

#### Filtration rating in µm

BN/HC, BH/HC, V: 3, 5, 10, 20  
 W/HC, W: 25, 50, 100, 200

#### Type of clogging indicator

Y plastic blanking plug in indicator port  
 A steel blanking plug in indicator port  
 B visual  
 C electrical  
 D visual and electrical

for other clogging indicators, see brochure no. 7.050.../..

#### Type code

1 model with one-piece filter bowls  
 2 model with two-piece filter bowls (only for DFDK 660 to 1320)  
 3 top-removable model (only DFDK 1320 to 3960)

#### Modification number

X the latest version is always supplied

#### Supplementary details

B. light with appropriate voltage (24, 48, 110, 220 Volt)  
 LED 2 light-emitting diodes up to 24 Volt  
 V FPM seals  
 W suitable for HFA and HFC emulsions

only for clogging indicators type "D"

### 2.2 REPLACEMENT ELEMENT

0160 D 010 BN4HC /-V

#### Size

0030, 0060, 0110, 0140, 0160, 0240, 0280, 0330, 0500, 0660, 0990, 1320

#### Type

D

#### Filtration rating in µm

BN4HC, BH4HC, V: 003, 005, 010, 020  
 W/HC, W: 025, 050, 100, 200

#### Filter material

BN4HC, BH4HC, V, W/HC, W

#### Supplementary details

V, W (for descriptions, see Point 2.1)

### 2.3 REPLACEMENT CLOGGING INDICATOR

VD 8 D . X /-L24

#### Type

VD Differential pressure indicator up to 420 bar operating pressure

#### Pressure setting

8 standard 8 bar, others on request

#### Type of clogging indicator

D (see Point 2.1)

#### Modification number

X the latest version is always supplied

#### Supplementary details

L..., LED, V, W (for descriptions, see Point 2.1)

### 3. FILTER CALCULATION / SIZING

The total pressure drop of a filter at a certain flow rate Q is the sum of the housing  $\Delta p$  and the element  $\Delta p$  and is calculated as follows:

$$\Delta p_{\text{total}} = \Delta p_{\text{housing}} + \Delta p_{\text{element}}$$

$$\Delta p_{\text{housing}} = (\text{see Point 3.1})$$

$$\Delta p_{\text{element}} = Q \cdot \frac{SK^*}{1000} \cdot \frac{\text{viscosity}}{30}$$

(\*see point 3.2)

For ease of calculation, our Filter Sizing Program is available on request free of charge.

**NEW:** Sizing online at [www.hydac.com](http://www.hydac.com)

#### 3.1 $\Delta p$ -Q HOUSING CURVES BASED ON ISO 3968

The housing curves apply to mineral oil with a density of 0.86 kg/dm<sup>3</sup> and a kinematic viscosity of 30 mm<sup>2</sup>/s. In this case, the differential pressure changes proportionally to the density.

**DFDK 30 ... 1.x**

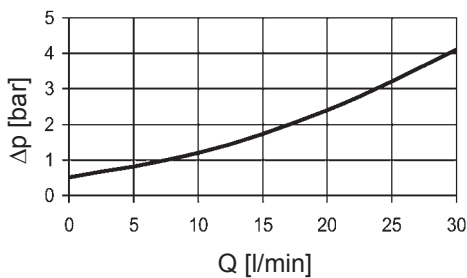

**DFDK 60, 110, 140 ... 1.x**

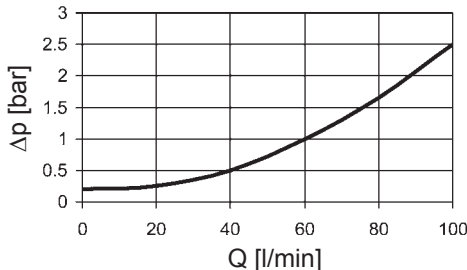

**DFDK 160, 240, 280 ... 1.x**

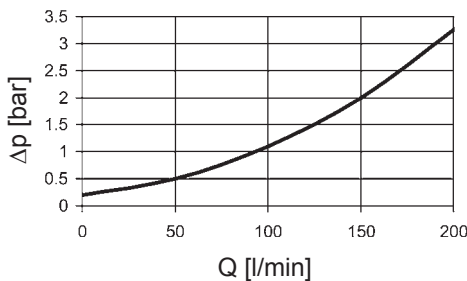

**DFDK 330, 500, 660 ... 1.x**  
**DFDK 660, 990, 1320 ... 2.x**

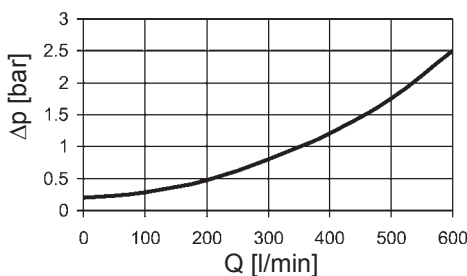

**DFDK 1320 ... 3.x**

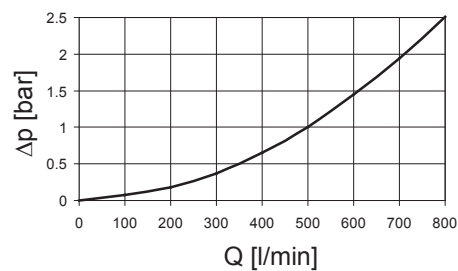

**DFDK 2640 ... 3.x**

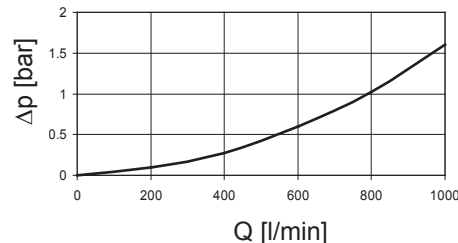

**DFDK 3960 ... 3.x**

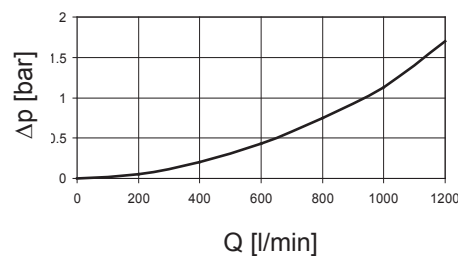

### 3.2 GRADIENT COEFFICIENTS (SK) FOR FILTER ELEMENTS

The gradient coefficients in mbar/(l/min) apply to mineral oils with a kinematic viscosity of 30 mm<sup>2</sup>/s. The pressure drop changes proportionally to the change in viscosity.

DFDK	V				W/HC, W	BH4HC			
	3 μm	5 μm	10 μm	20 μm		3 μm	5 μm	10 μm	20 μm
30	18.4	13.5	7.5	3.6	3.030	91.2	50.7	36.3	19.0
60	16.0	9.3	5.4	3.3	0.757	58.6	32.6	18.1	12.2
110	8.2	5.6	3.3	2.2	0.413	25.4	14.9	8.9	5.6
140	5.8	4.8	3.1	2.3	0.324	19.9	11.3	8.1	4.3
160	4.6	3.2	2.3	1.4	0.284	16.8	10.4	5.9	4.4
240	3.1	2.5	1.7	1.1	0.189	10.6	6.8	3.9	2.9
280	2.3	1.7	1.2	0.8	0.162	5.7	3.4	1.8	1.6
330	2.2	1.8	1.2	0.8	0.138	7.7	4.5	2.8	2.0
500	1.5	1.2	0.8	0.5	0.091	4.2	2.6	1.5	1.2
660	1.1	0.9	0.6	0.4	0.069	3.3	1.9	1.0	0.9
990	0.8	0.6	0.4	0.3	0.046	2.2	1.3	0.8	0.6
1320	0.6	0.5	0.3	0.2	0.035	1.6	1.0	0.6	0.4

**BN4HC: DFDK... 30**

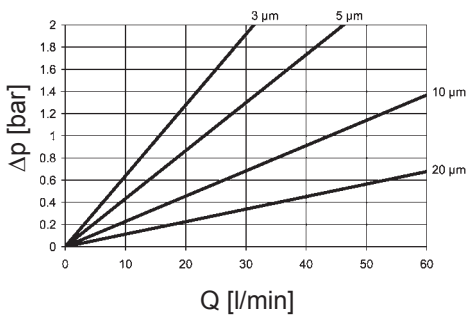

**BN4HC: DFDK... 60**

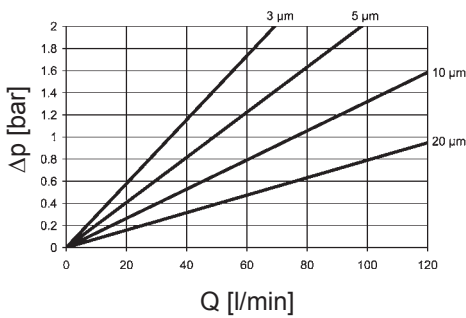

**BN4HC: DFDK... 110**

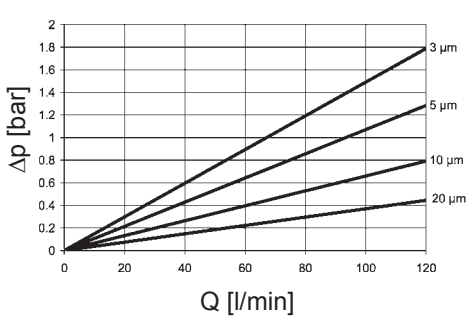

**BN4HC: DFDK... 140**

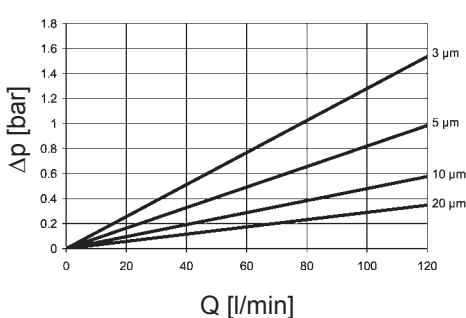

**BN4HC: DFDK... 160**

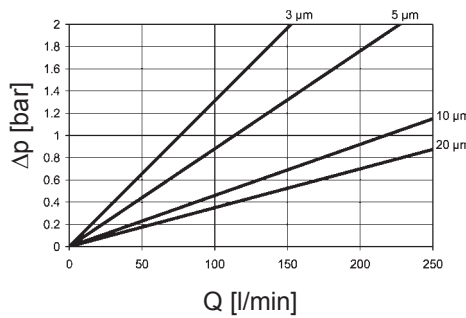

**BN4HC: DFDK... 240**

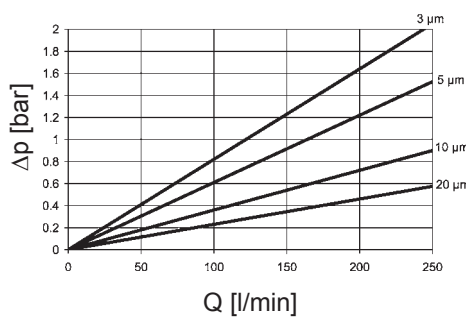

**BN4HC: DFDK... 280**

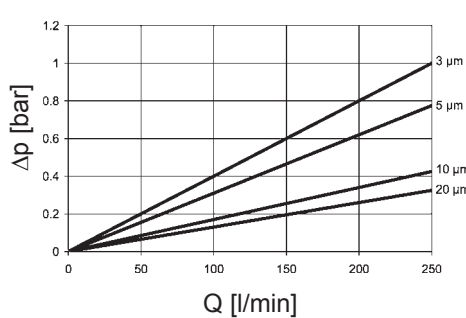

**BN4HC: DFDK... 330**

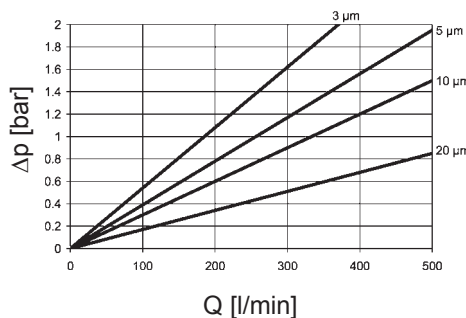

**BN4HC: DFDK... 500**

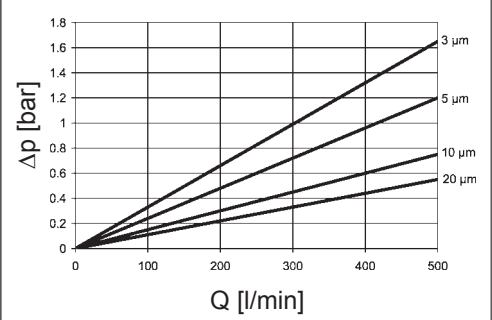

**BN4HC: DFDK... 660**

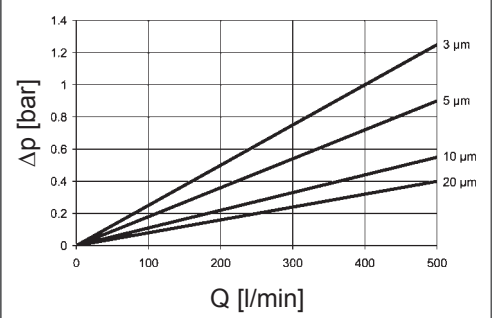

**BN4HC: DFDK... 990**

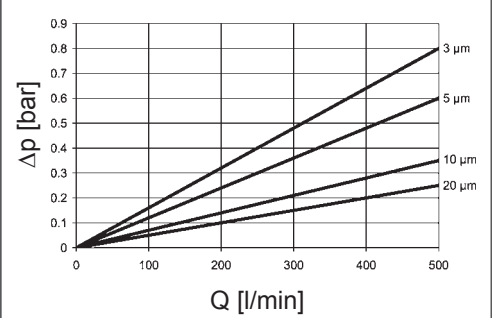

**BN4HC: DFDK... 1320**

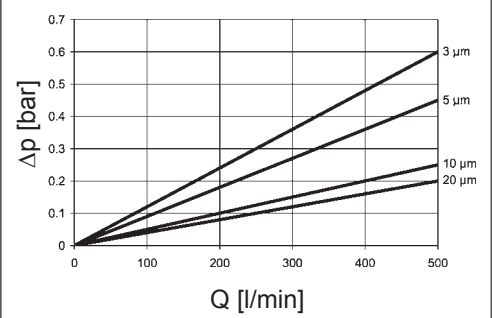

## 4. DIMENSIONS

DFDK 30 - 280

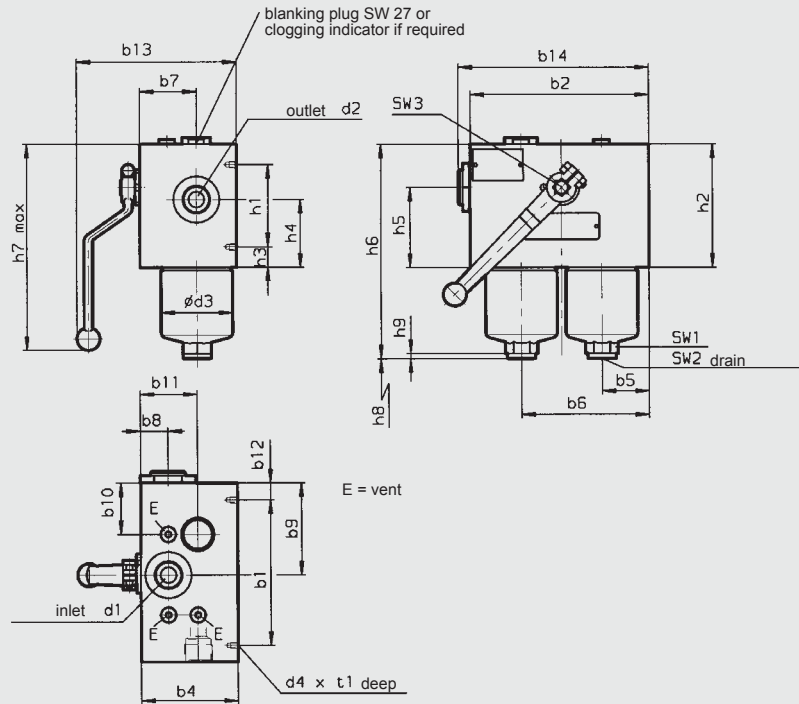

\* SAE connection 6000 psi

DFDK	30	60	110	140	160	240	280
b1	130	138	138	138	190	190	190
b2	145	170	170	170	210	210	210
b4	80	92	92	92	128	128	128
b5	35	45	45	45	52.5	52.5	52.5
b6	96	121.5	121.5	121.5	157.5	157.5	157.5
b7	47	54	54	54	75.5	75.5	75.5
b8	22.8	26	26	26	35.5	35.5	35.5
b9	80.9	87	87	87	105	105	105
b10	80.9	48.5	48.5	48.5	52.5	52.5	52.5
b11	59	54	54	54	75.5	75.5	75.5
b12	7.5	16	16	16	10	10	10
b13 (≈)	131	150	150	150	193	193	193
b14 (≈)	155	181	181	181	221	221	221
d1*	G ½	G ¾	G ¾	G ¾	G 1½	G 1½	G 1½
d2*	G ½	G ¾	G ¾	G ¾	G 1½	G 1½	G 1½
d3	52.2	68.2	68.2	68.2	95.2	95.2	95.2
d4	M6	M6	M6	M6	M10	M10	M10
h1	64	78	78	78	96	96	96
h2	80	117	117	117	162	162	162
h3	8	19.5	19.5	19.5	33	33	33
h4	47	64.5	64.5	64.5	106	106	106
h5	43	76	76	76	100	100	100
h6	171	204.5	272.0	315.5	282.5	342.5	524.5
h7 (≈)	180	205	205	205	245	245	245
h8	75	75	75	75	85	85	85
h9	5	5	5	5	5	5	5
t1	7	7	7	7	11	11	11
SW1	24	27	27	27	32	32	32
SW2	6	10	10	10	10	10	10
SW3	9	12	12	12	14	14	14
Weight incl. element [kg]	7.4	15.0	17.0	18.9	33.0	36.0	45.0
Volume of pressure chamber [l]	2x0.13	2x0.20	2x0.33	2x0.40	2x0.60	2x0.80	2x1.60

DFDK 330 - 660..1.x

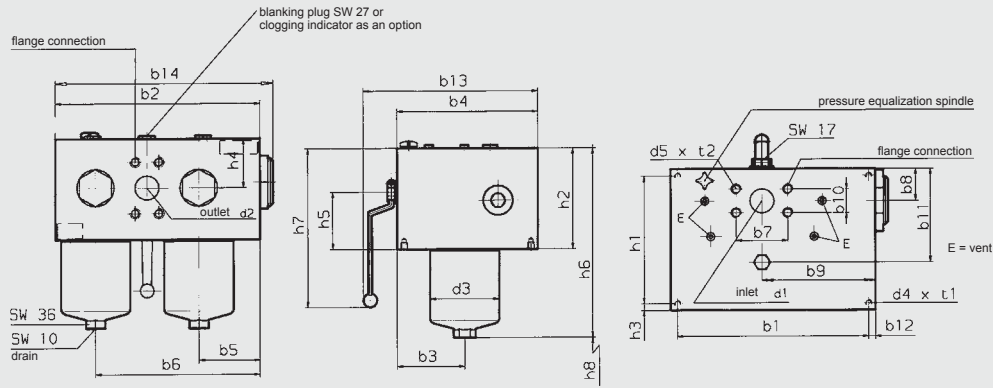

DFDK 660 - 1320..2.x

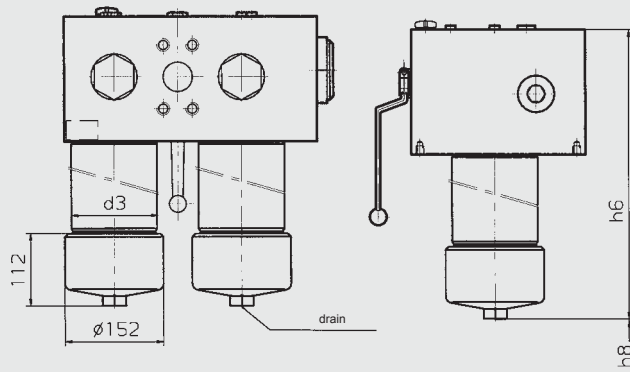

\* SAE connection 6000 psi

DFDK	330	500	660 1.x	660 2.x	990	1320
b1	359	359	359	359	359	359
b2	385	385	385	385	385	385
b3	127	127	127	127	127	127
b4	265	265	265	265	265	265
b5	115	115	115	115	115	115
b6	309	309	309	309	309	309
b7	96.8	96.8	96.8	96.8	96.8	96.8
b8	60.5	60.5	60.5	60.5	60.5	60.5
b9	212	212	212	212	212	212
b10	44.5	44.5	44.5	44.5	44.5	44.5
b11	175.5	175.5	175.5	175.5	175.5	175.5
b12	13	13	13	13	13	13
b13 (≈)	326	326	326	326	326	326
b14 (≈)	405	405	405	405	405	405
d1*	DN 50 (2")	DN 50 (2")	DN 50 (2")	DN 50 (2")	DN 50 (2")	DN 50 (2")
d2*	DN 50 (2")	DN 50 (2")	DN 50 (2")	DN 50 (2")	DN 50 (2")	DN 50 (2")
d3	130.2	130.2	130.2	130	130	130
d4	M12	M12	M12	M12	M12	M12
d5	M20	M20	M20	M20	M20	M20
h1	239	239	239	239	239	239
h2	190	190	190	190	190	190
h3	13	13	13	13	13	13
h4	98	98	98	98	98	98
h5	108	108	108	108	108	108
h6	357.5	450.5	527.0	521.5	677.5	843.5
h7 (≈)	309	309	309	309	309	309
h8	95	95	95	95	500	670
t1	13	13	13	13	13	13
t2	27	27	27	27	27	27
Weight incl. element [kg]	151.5	159.0	165.0	171.0	184.4	202.4
Volume of pressure chamber [l]	2x1.50	2x2.20	2x3.00	2x3.00	2x4.50	2x6.00

DFDK top-removable models 1320, 2640, 3960 ... 3.x

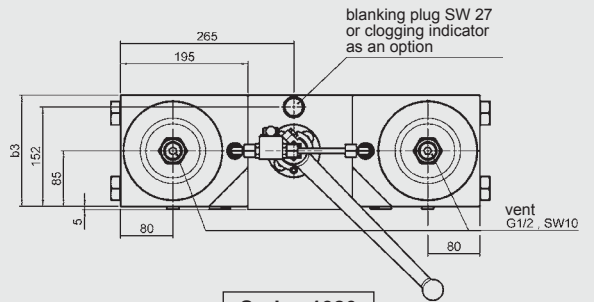
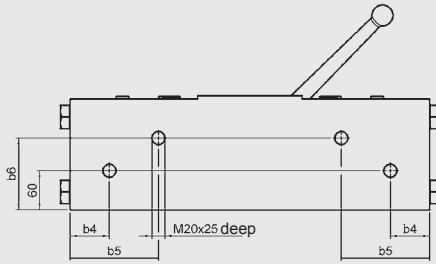

Series 1320

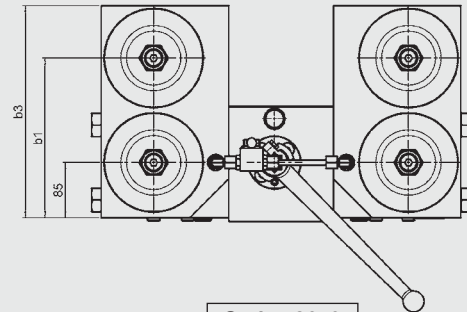

Series 2640

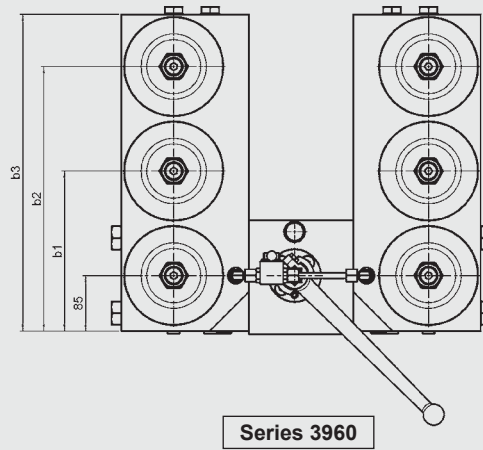

Series 3960

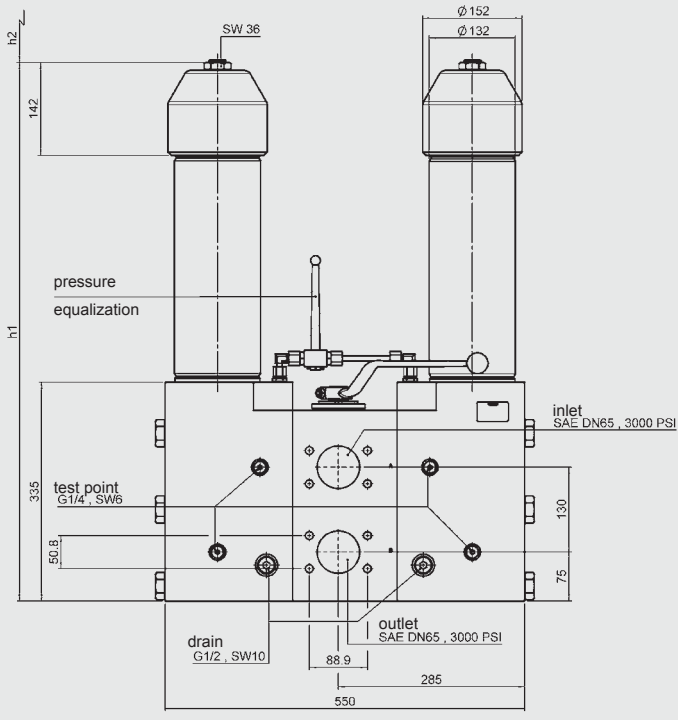

DFDK	1320 ... 3.x	2640 ... 3.x	3960 ... 3.x
b1	-	245	245
b2	-	-	405
b3	170	325	485
b4	60	135	135
b5	135	135	135
b6	110	265	425
h1	991	991	991
h2	570	570	570
Weight incl. element [kg]	approx. 250	approx. 445	approx. 640
Vol. of pressure chamber [l]	2 x 7.00	2 x 14.00	2 x 20.00

