

# MOBS-PR | Clamps with extended lever, horizontal series

with straight base and anti-release lever, steel



**MATERIAL**  
C10 zinc-plated steel.



**RIVETS**  
Zinc-plated steel.



**SUPPORT BUSHINGS**  
Ground and hardened steel.



**HANDLE**  
Polyurethane, red colour.



**LEVER ANTI-RELEASE COVERING**  
Polyvinylchloride (PVC).



**SPRING**  
AISI 302 stainless steel.



**CLAMPING BOLT**  
To be ordered separately.



**FEATURES AND APPLICATIONS**  
Safety stop to prevent accidental opening or closing in the presence of strong vibrations.  
The operator's fingers cannot be hit by the lever while opening.  
During clamping, the lever is controlled to prevent impact on functioning due to side thrust.  
The main characteristic of the MOBS-PR clamp is the special extension of the locking arm to assist the specific use in checking templates.

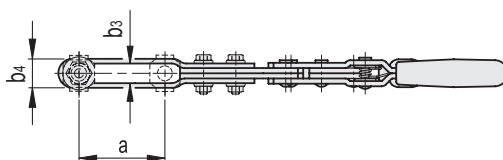
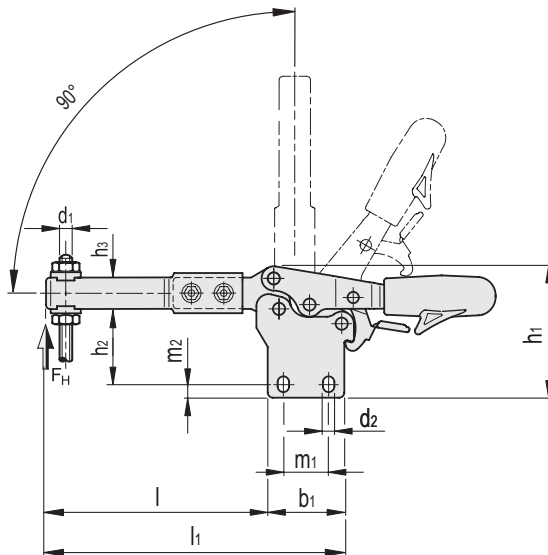
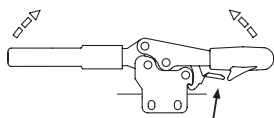

Toggle and fastening clamps

Code	Description	a	b1	b3	b4	d1	d2	h1	h2	h3	l	l1	m1	m2	FH [N]*	ΔΔ
GG.AD151	MOBS-PR.130/PLS	67.5	36	6.3	11.3	M5	5.6	64.5	35+38	16	135	171	26	5.8+8.8	600	295
GG.AD297	MOBS-PR.230/PLS	71.5	44	8.2	14.2	M6	6.6	75.5	42+44.5	18	152	196	26	6.5	1100	485

\* Holding force.