

MOUNTING RAIL 45MM FOR MOUNTING ONTO 3-PHASE BUSBARS 3RV1917-1/4; 3RV2917-1/4

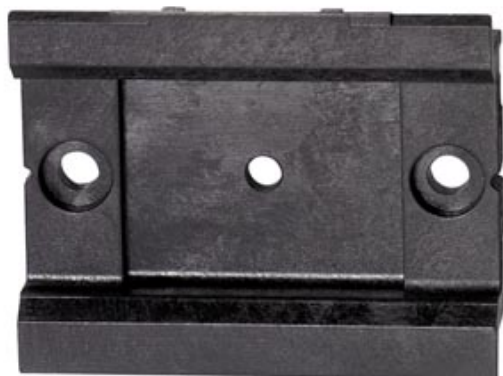

Installation/ mounting/ dimensions:

Mounting type

screw fixing

Further information

Information- and Downloadcenter (Catalogs, Brochures,...)

<http://www.siemens.com/industrial-controls/catalogs>

Industry Mall (Online ordering system)

<http://www.siemens.com/industrymall>

Cax online generator

<http://support.automation.siemens.com/WW/CAXorder/default.aspx?lang=en&mlfb=3RV19177B>

Service&Support (Manuals, Certificates, Characteristics, FAQs,...)

<http://support.automation.siemens.com/WW/view/en/3RV19177B/all>

Image database (product images, 2D dimension drawings, 3D models, device circuit diagrams, EPLAN macros, ...)

<http://www.automation.siemens.com/bilddb/index.aspx?attID9=3RV19177B&lang=en>

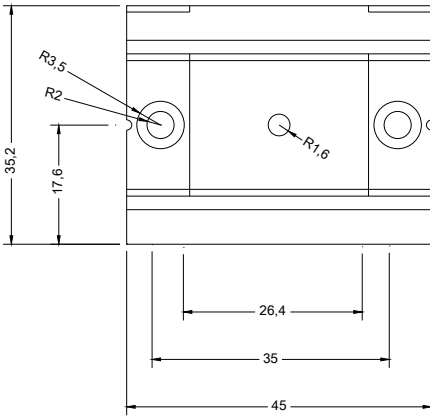

last modified:

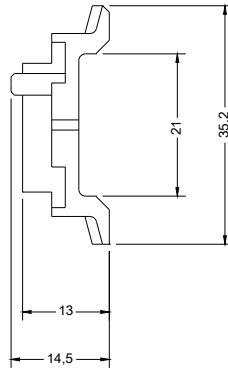

09.03.2015