

DISPLAY Elektronik GmbH

DATA SHEET

TFT MODULE

**DEM 320240G1 TMH-PW-N
(C-TOUCH)**

3,5" + PCT

Product Specification

Version:2

14.06.2016

GENERAL SPECIFICATION

MODULE NO. :

DEM 320240G1 TMH-PW-N(C-TOUCH)

CUSTOMER

VERSION NO.	CHANGE DESCRIPTION	DATE
0	ORIGINAL VERSION	03.06.2016
1	CHANGE MODULE DRAWING	03.06.2016
2	ADD TOUCH PANEL FEATURES	14.06.2016

PREPARED BY: YH

DATE: 14.06.2016

APPROVED BY: MH

DATE: 14.06.2016

CONTENTS

1. GENERAL SPECIFICATIONS.....2

2. EXTERNAL DIMENSIONS4

3. BLOCK DIAGRAM6

4. PIN ASSIGNMENT7

5. OPTICAL CHARACTERISTICS9

6. ABSOLUTE MAXIMUM RATINGS.....12

7. ELECTRICAL CHARACTERISTICS.....13

8. RELIABILITY TEST18

9. LCD MODULES HANDLING PRECAUTIONS.....19

10. OTHERS19

1. GENERAL SPECIFICATIONS

Item	Contents	Unit
LCD TYPE	TFT/TRANSMISSIVE	
MODULE SIZE (W*H*T)	76.90*63.90*4.60	MM
ACTIVE SIZE (W*H)	70.08*52.56	MM
PIXEL PITCH (W*H)	0.219*0.219	MM
NUMBER OF DOTS	320 *RGB *240	
DIVER IC	HX8238D	
INTERFACE TYPE	24BIT RGB+SPI	
TOP POLARIZER TYPE	ANTI-GLARE	
RECOMMEND VIEWING DIRECTION	12:00	O'CLOCK
GRAY SCALE INVERSION DIRECTION	6:00	O'CLOCK
COLORS	16.7 Million	
BACKLIGHT TYPE	6-DIES WHITE LED	
TOUCH PANEL TYPE	CTP	

TOUCH PANEL FEATURES:

Item	Contents
Type	Capacitive Multi-touch
Module size(Without FPC)	76.90 (L)mm*63.90(W)mm*1.40 (T) mm
View area	71.08(W)mm*53.56(H)mm
Drive IC	ILI2139C
Interface	I2C
Operation Voltage	2.6V~3.6V
ITO Glass thickness	0.4mm
Operation humidity	20~90%RH
Storage humidity	20~90%RH
Resolution	≧ 1024x768
Input force	≧ 10g
Input method	Finger or exclusive pen
Transparency	≧ 88%
Surface hardness	>6H
Hitting life	>35,000,000 times
Insulation	20M ohm or over(Dc 25V)
ESD(Human body model)	4,000 V
Application	The product is touch panels used as the input devices for General electric appliances and OA equipment
Scope	This specification applies for finger input transparent touch Panels.(Those mentioned in the individual specification shall be given priority)

2. EXTERNAL DIMENSIONS

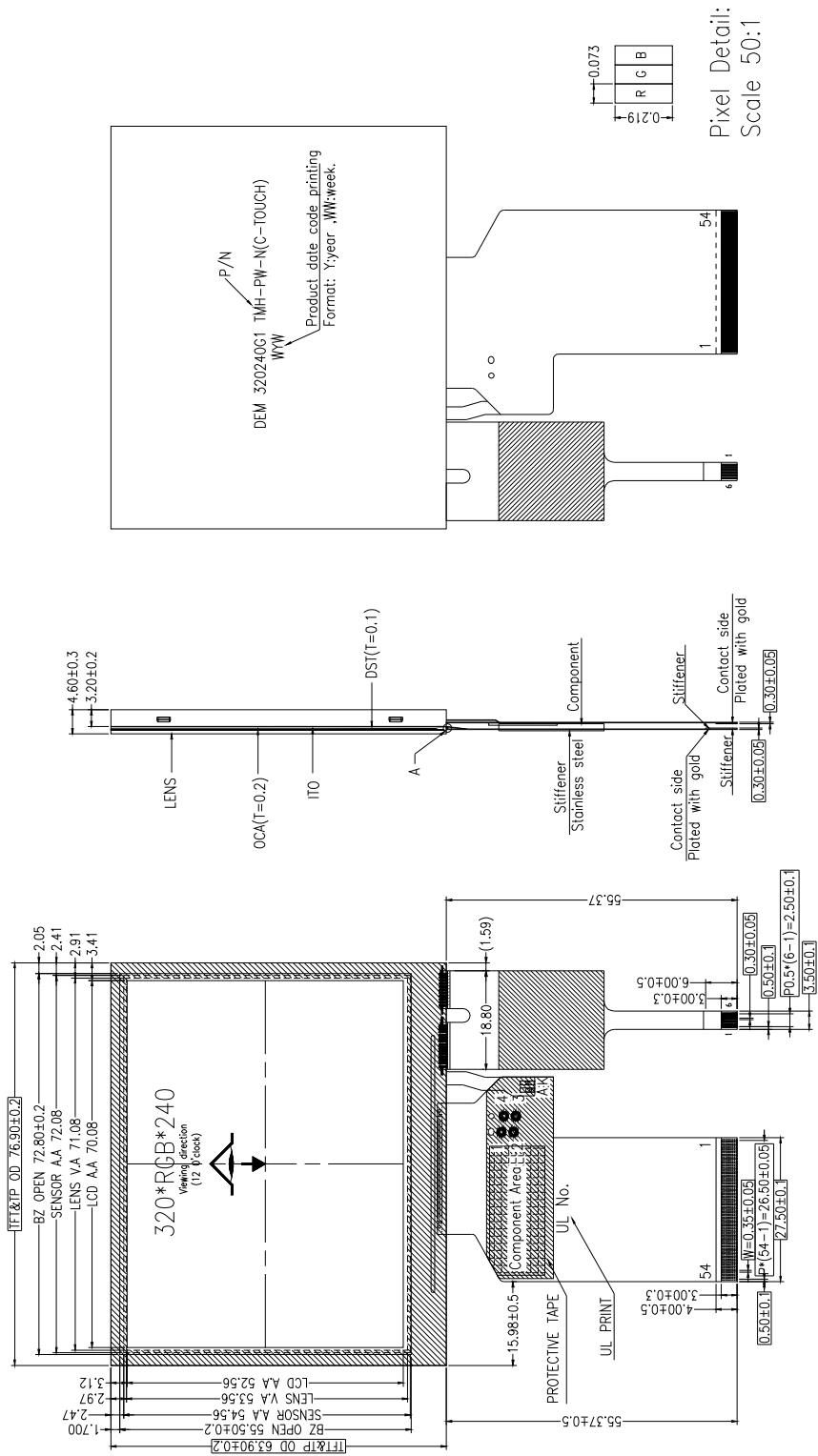

Pixel Detail:
Scale 50:1

Circuit Diagram

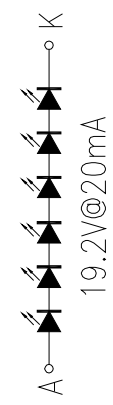

Remark:

1. Unmarked tolerance is ± 0.3
2. All materials comply with RoHS
3. \squarecritical dimension.

Touch panel detail information please refer to CTPF195 specification

TOUCH PANEL DRAWING

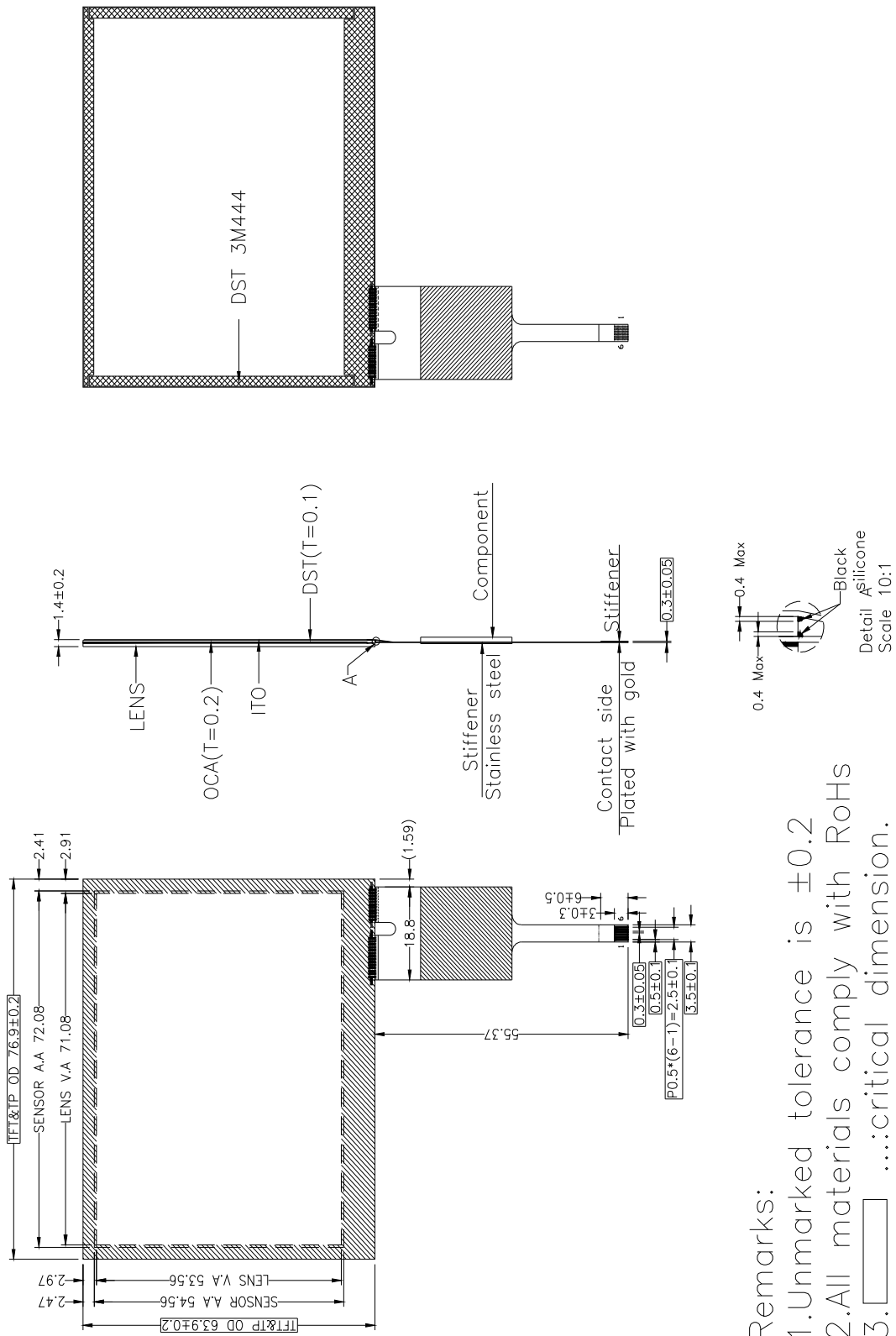

Remarks:
 1. Unmarked tolerance is ±0.2
 2. All materials comply with RoHs
 3. ...critical dimension.

3. BLOCK DIAGRAM

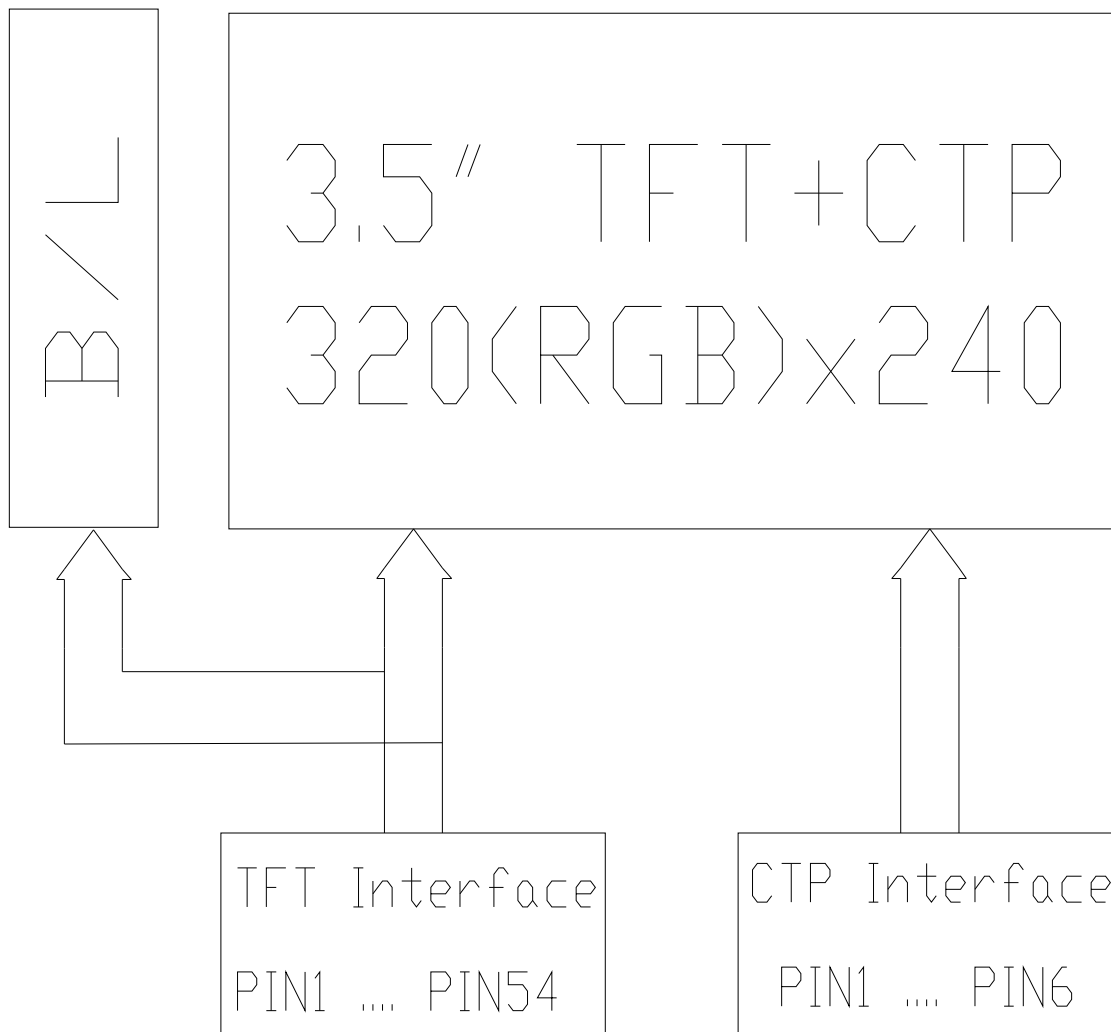

4. PIN ASSIGNMENT

Pin No.	Symbol	Description
1	LEDK	Cathode of LED backlight
2	LEDK	Cathode of LED backlight
3	LEDA	Anode of LED backlight
4	LEDA	Anode of LED backlight
5	NC	No connect
6	NC	No connect
7	NC	No connect
8	RESET	RESET PIN
9	SPENA	Chip select of serial interface
10	SPCLK	Clock pin of serial interface
11	SPDAT	Data input pin of serial interface
12~19	B0~B7	Blue data bus
20~27	G0~G7	Green data bus
28~35	R0~R7	Red data bus
36	HSYNC	Horizontal sync signal; negative polarity
37	VSNC	Vertical sync signal; negative polarity
38	DCLK	Clock signal; latching data at the falling edge
39	NC	No connect
40	NC	No connect
41	VDD	Power supply
42	VDD	Power supply
43	NC	No connect
44	NC	No connect
45	NC	No connect
46	NC	No connect
47	NC	No connect
48	SEL2	Interface mode select(*Note)
49	SEL1	
50	SEL0	
51	NC	No connect
52	DEN	Display enable pin from controller
53	GND	Power ground
54	GND	Power ground

Note :

1. The mode control (SEL2) not use ,it can' t control CCIR601 interface , If not use CCIR601 ,it can floating.
 2. For digital RGB input data format, both SYNC mode and DE-SYNC mode are supported. If DE signal is fixed low, SYNC mode is used. Otherwise, DE+SYNC mode is used.Suggest used SYNC mode!!Suggest the DE signal usually pull low.
 3. If select serial RGB or CCIR601/656 input mode is selected,only DX0-DX7 used,and the other short to GND, Only selected serial RGB、 CCIR601/656 interface,DX BUS will enable.Digital input mode DX0 is LSB and DX7 is MSB.
- interface select table

SEL2	SEL1	SEL0	Interface Mode
0	0	0	Parallel-RGB Data format interface (only support stripe type color filter)
0	0	1	Serial-RGB data format
0	1	0	CCIR 656 data format (640RGB)
0	1	1	CCIR 656 data format (720RGB)
1	0	0	YUV mode A data format(Cr-Y-Cb-Y)
1	0	1	YUV mode A data format(Cr-Y-Cb-Y)
1	1	0	YUV mode B data format(Cb-Y-Cr-Y)
1	1	1	YUV mode B data format(Cb-Y-Cr-Y)

TOUCH PANEL:

Pin No.	Symbol	Description
1	INT	External Interrupt
2	RST	Global reset input, low active
3	SDA	SPI Master data out /Slave data in I2C Serial data input/output TDI(JTAG_SEL=0 & RESETB=L)
4	SCL	SPI Serial clock input/output I2C Serial clock input/output TCK(JTAG_SEL=0 & RESETB=L)
5	VDD	Positive power supply
6	GND	Negative supply

5. OPTICAL CHARACTERISTICS

ITEM	SYMBOL	CONDITIONS	SPECIFICATIONS			UNIT	NOTE
			MIN	TYP.	MAX		
Luminance	L	$I_L = 20\text{mA}$		240		Cd/m^2	
Contrast Ratio	CR	$\theta = 0^\circ$	200	300			
Response Time	T_{ON}	25 °C		15	30	ms	
	T_{OFF}			35	50		
CIE Color Coordinate	Red	X_R		0.6063			
		Y_R		0.3636			
	Green	X_G		0.3341			
		Y_G		0.6040			
	Blue	X_B		0.1412			
		Y_B		0.0908			
	White	X_W		0.2842			
		Y_W		0.3182			
Viewing Angle	Hor.	θ_{x+}	50	60		Degree	
		θ_{x-}	50	60			
	Ver.	θ_{y+}	30	40			
		θ_{y-}	50	60			
Uniformity	Un		80			%	

Note 1: Definition of Viewing Angle θ_x and θ_y :

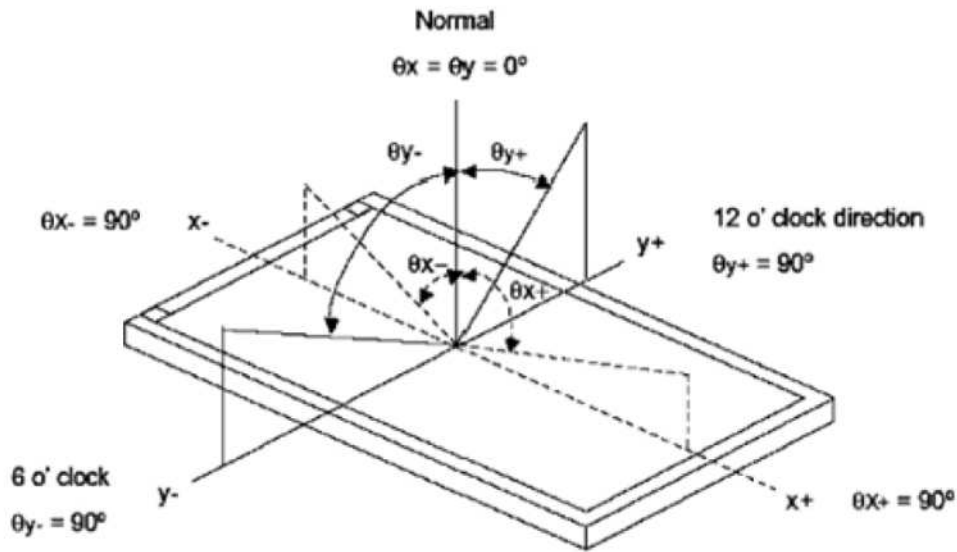

Note 2: Definition of contrast ratio CR:

$$CR = \frac{\text{Luminance of white state}}{\text{Luminance of black state}}$$

Note 3: Definition of Response Time (T_r, T_f)

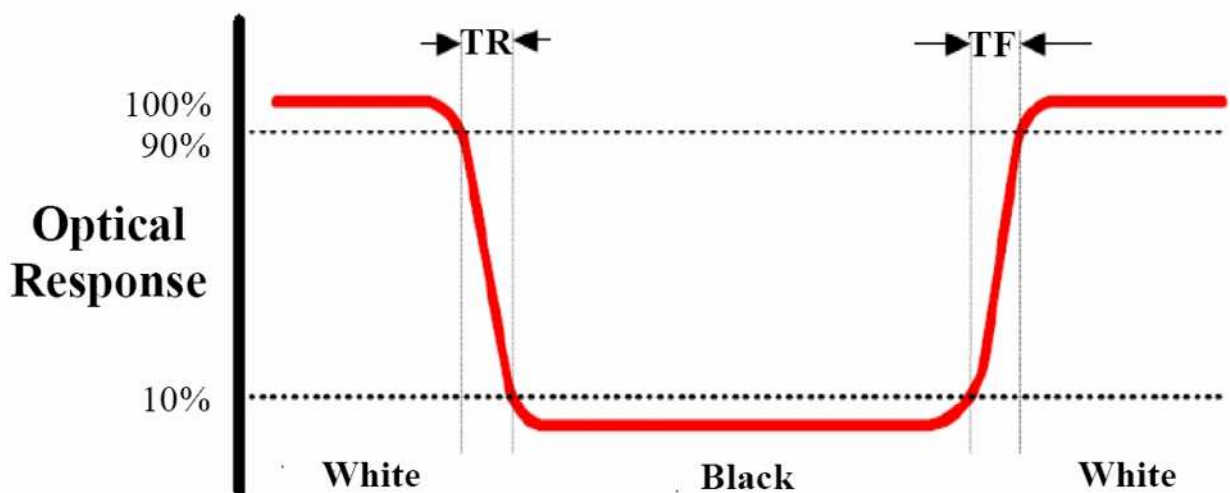

Note 4: Definition of Luminance

①The Brightness Test Equipment Setup

Field=2° (As measuring “black” image, field=2° is the best testing condition)

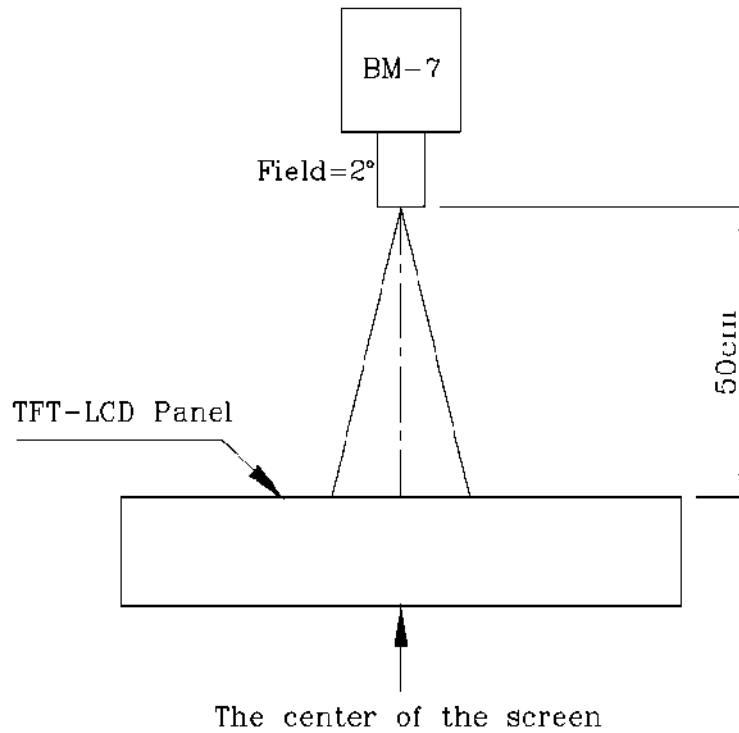

②The Brightness Test Point Setup

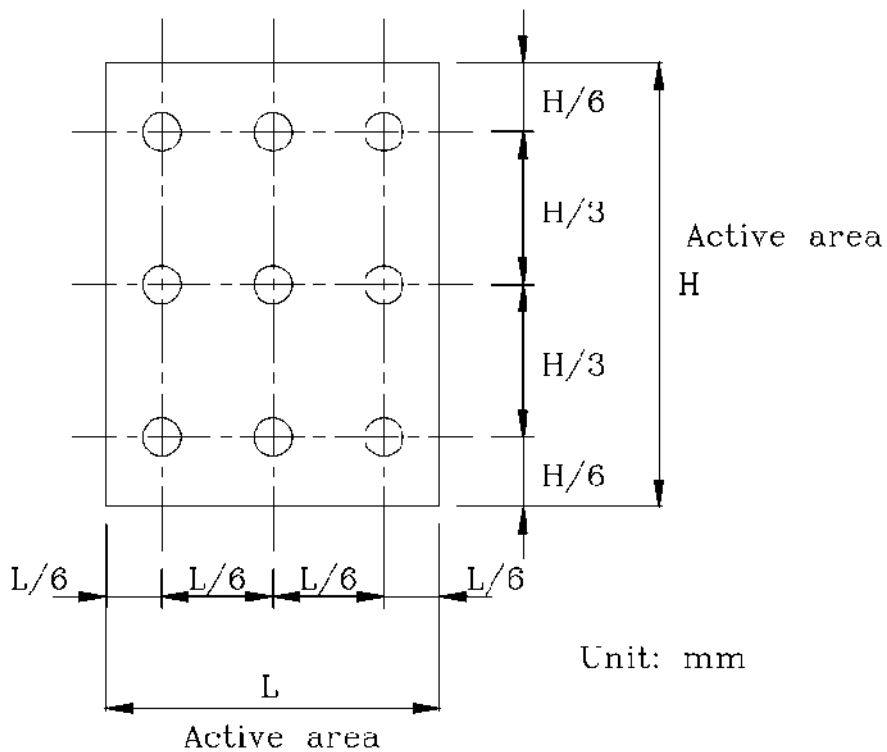

6. ABSOLUTE MAXIMUM RATINGS

Parameter	Symbol	Min	Max	Unit
Supply voltage for analog	VDD	-0.3	4.5	V
Supply voltage for logic	VDD	-0.3	4.5	V
Supply current (One LED)	I _{LED}		30	mA
Operating temperature	T _{OP}	-20	+70	°C
Storage temperature	T _{ST}	-30	+80	°C

Note : The absolute maximum rating values of this product are not allowed to be exceeded at any times. Should a module be used with any of the absolute maximum ratings exceeded, the characteristics of the module may not be recovered, or in an extreme case, the module may be permanently destroyed.

TOUCH PANEL:

Item	Symbol	Min	Max	Unit
Voltage on VDD with respect to GND	VDD	-0.3	4.2	V
Operating temperature	Topr	-40	+85	°C
Storage temperature	Tstg	-40	+85	°C

7. ELECTRICAL CHARACTERISTICS

7.1 INPUT POWER

Item	Symbol	Min	Typ.	Max	Unit	Applicable terminal
Supply Voltage for Analog	VDD	3.0	3.3	3.6	V	
Supply Voltage for Logic	VDD	3.0	3.3	3.6	V	
Input Voltage	V _{IL}	GND	-	0.3VCC	V	
	V _{IH}	0.7 VCC	-	VCC		
Input leakage Current	I _{LKG}	-1		1	μA	

7.2 BLACKLIGHT DRIVING CONDITIONS

Item	Symbol	Value			Unit	Remark
		Min.	Typ.	Max.		
Voltage for LED Backlight	V _{I'}	-	19.2	-	V	I _L = 20mA
Current for LED Backlight	I _L		20	30	mA	
Power Consumption	P		0.384		W	
LED Life Time		30,000	50,000		Hr	Note

Note: Brightness to be decreased to 50% of the initial value at ambient temperature TA=25°C

7.3 AC CHARACTERISTICS

7.3.1 Pixel Timing Diagram

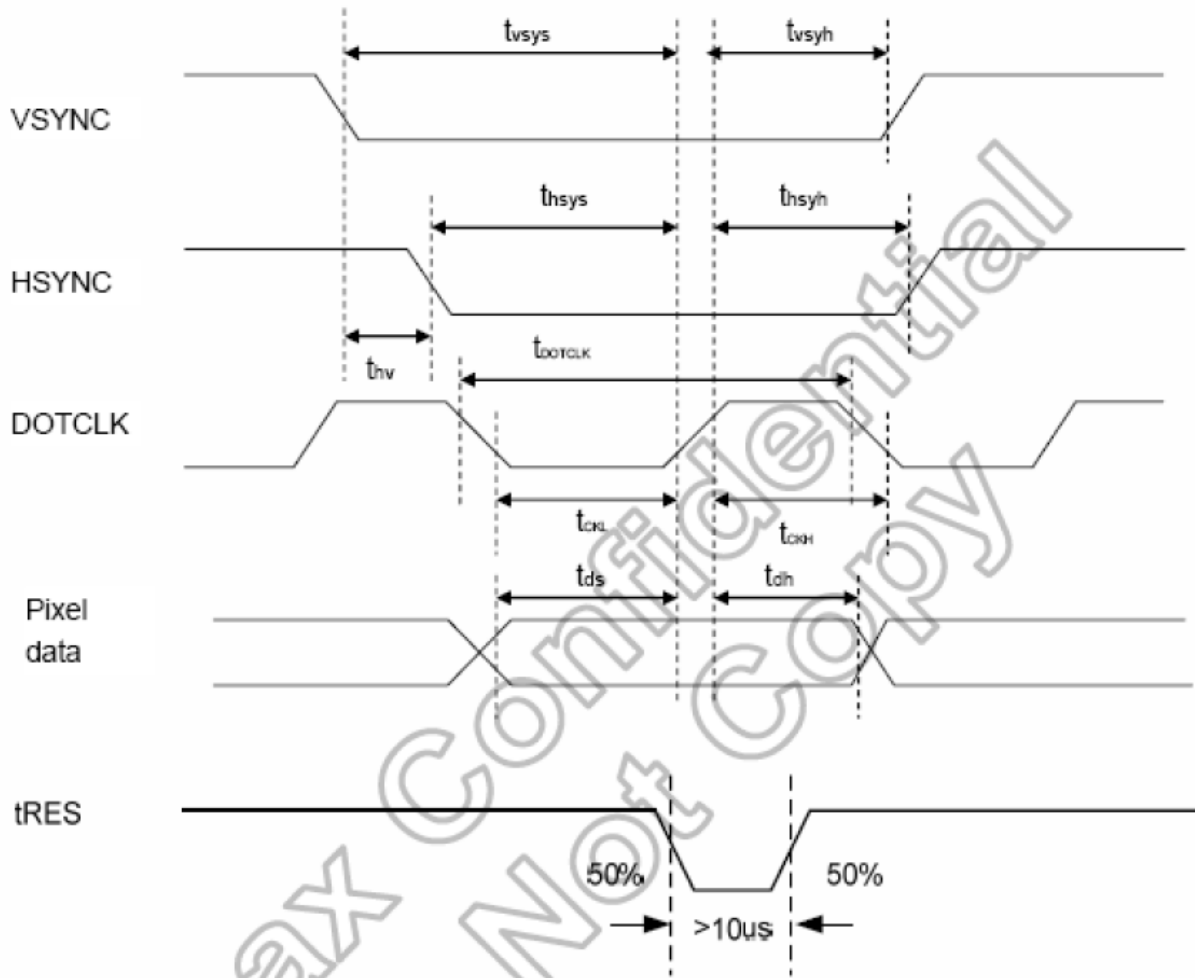

Characteristics	Symbol	Min.		Typ.		Max.		Unit
		24 bit	8 bit	24 bit	8 bit	24 bit	8 bit	
DOTCLK Frequency	fDOTCLK	-	-	6.5	19.5	10	30	MHz
DOTCLK Period	tDOTCLK	100	33.3	154	51.3	-	-	ns
Vertical Sync Setup Time	tvsys	20	10	-	-	-	-	ns
Vertical Sync Hold Time	tvsyh	20	10	-	-	-	-	ns
Horizontal Sync Setup Time	thsys	20	10	-	-	-	-	ns
Horizontal Sync Hold Time	thsyh	20	10	-	-	-	-	ns
Phase difference of Sync Signal Falling Edge	thv	1		-		240		tDOTCLK
DOTCLK Low Period	tCKL	50	15	-	-	-	-	ns
DOTCLK High Period	tCKH	50	15	-	-	-	-	ns
Data Setup Time	tds	12	10	-	-	-	-	ns
Data hold Time	tdh	12	10	-	-	-	-	ns
Reset pulse width	tRES	10		-		-		µs

Note: External clock source must be provided to DOTCLK pin of HX8238-D. The driver will not operate if absent of the clocking signal.

7.3.2 SYNC mode Timing Diagram

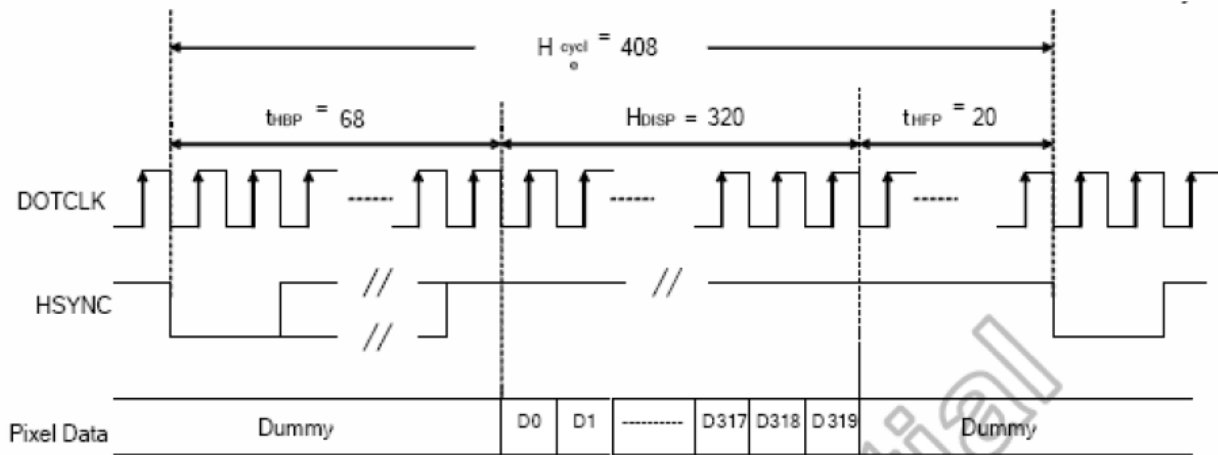

(a) Horizontal Data Transaction Timing

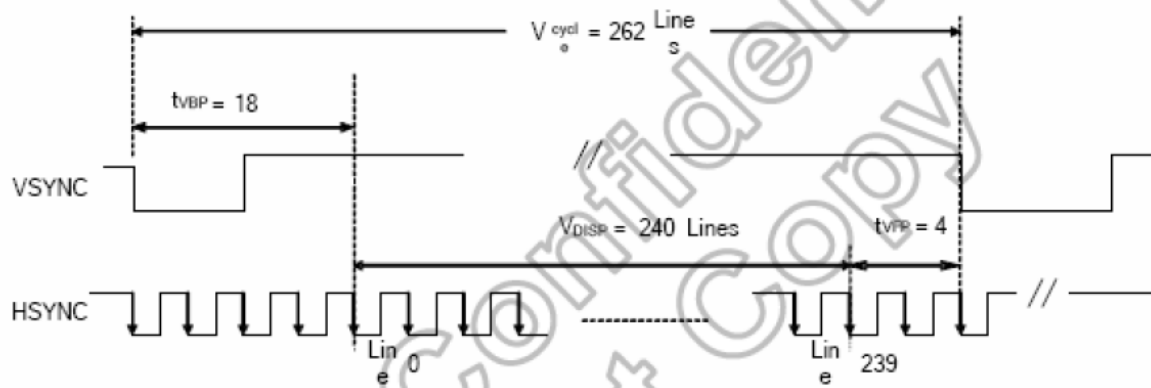

(b) Vertical Data Transaction Timing

Characteristics	Symbol	Min.		Typ.		Max.		Unit
		24 bit	8 bit	24 bit	8 bit	24 bit	8 bit	
DOTCLK Frequency	fDOTCLK	-	-	6.5	19.5	10	30	MHz
DOTCLK Period	tDOTCLK	100	33.3	154	51.3	-	-	ns
Horizontal Frequency (Line)	fH	-	-	14.9		22.35		KHz
Vertical Frequency (Refresh)	fV	-	-	60		90		Hz
Horizontal Back Porch	tHBP	-	-	68	204	-	-	tDOTCLK
Horizontal Front Porch	tHFP	-	-	20	60	-	-	tDOTCLK
Horizontal Data Start Point	tHBP	-	-	68	204	-	-	tDOTCLK
Horizontal Blanking Period	tHBP + tHFP	-	-	88	264	-	-	tDOTCLK
Horizontal Display Area	H_DISP	-	-	320	960	-	-	tDOTCLK
Horizontal Cycle	Hcycle	-	-	408	1224	450	1350	tDOTCLK
Vertical Back Porch	tVBP	-	-	18		-	-	Lines
Vertical Front Porch	tVFP	-	-	4		-	-	Lines
Vertical Data Start Point	tVBP	-	-	18		-	-	Lines
Vertical Blanking Period	tVBP + tVFP	-	-	22		-	-	Lines
Vertical Display Area	NTSC	V_DISP	-	240		-	-	Lines
	PAL			280(PALM=0)				
	PAL			288(PALM=1)				
Vertical Cycle	NTSC	Vcycle	-	262		350	-	Lines
	PAL			313				

7.3.3 DE mode Timing Diagram

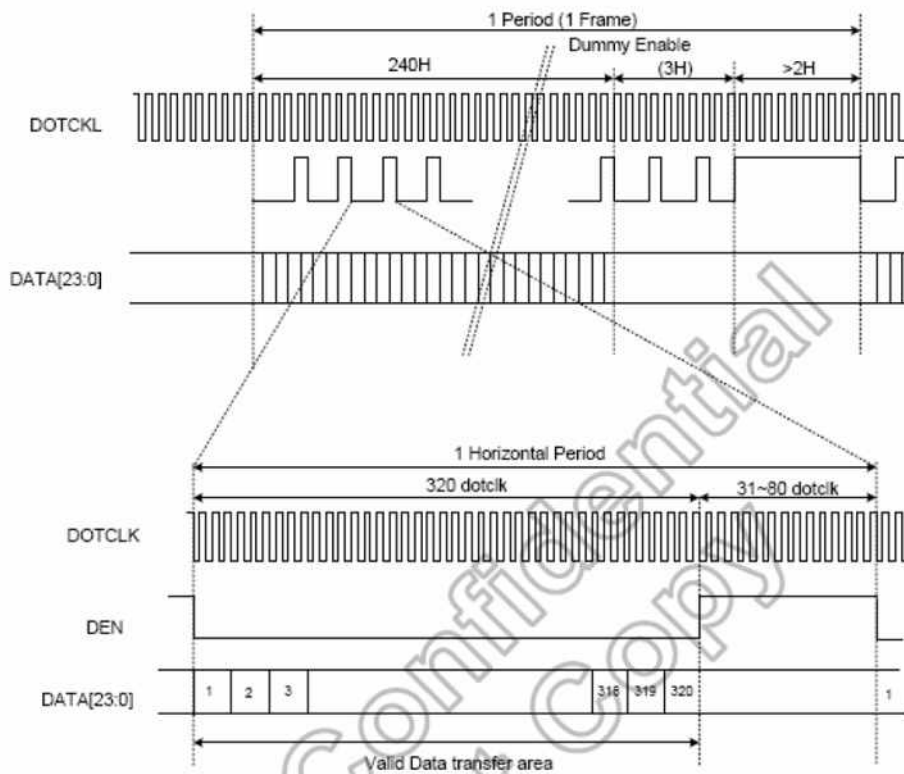

Characteristics	Symbol	Min.		Typ.		Max.		Unit
		24-bit	8-bit	24-bit	8-bit	24-bit	8-bit	
DOTCLK Frequency	fDOTCLK	-	-	6.5	19.5	10	30	MHz
DOTCLK Period	tDOTCLK	100	33.3	154	51.3	-	-	ns
Horizontal Blanking Period	tHBP + tHFP	52	146	88	264	180	960	tDOTCLK
Horizontal Display Area	HDISP	-	-	320	960	-	-	tDOTCLK
Horizontal Cycle	Hcycle	372	1106	408	1224	500	1920	tDOTCLK
Vertical Blanking Period	tVBP + tVFP	2	-	-	-	47	-	Lines
Vertical Display Area	VDISP	-	-	240	-	-	-	Lines
Vertical Cycle	Vcycle	242	-	-	-	287	-	Lines

Note: The above parallel RGB interface timing sequence is for reference only. For the other interface timing sequence, please refer to the driver IC (HX8238D) data sheet.

TOUCH PANEL:

DC CHARACTERISTICS

Parameter	Symbol	Min	Typ	Max	Unit
Supply Voltage	VDD	2.6	3.3	3.6	V
Supply Current	IDD	---	TBD	---	mA

AC CHARACTERISTICS

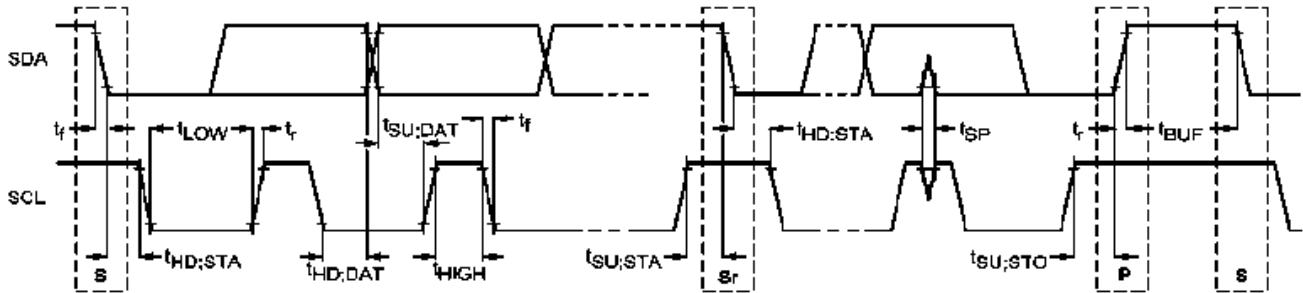

Symbol	Parameter						
		Min	Max	Unit	Min	Max	Unit
f _{SCL}	SCL clock frequency	0	100	kHz	0	400	kHz
t _{HD,STA}	Hold time (repeated) START condition. After this period, the first clock pulse is generated	4.0	–	μs	0.6	–	μs
t _{LOW}	LOW period of the SCL clock	4.7	–	μs	1.3	–	μs
t _{HIGH}	HIGH period of the SCL clock	4.0	–	μs	0.6	–	μs
t _{SU,STA}	Set-up time for a repeated START condition	4.7	–	μs	0.6	–	μs
t _{HD,DAT}	Data hold time	5.0	–	μs	0	0.9	μs
t _{SU,DAT}	Data set-up time	250	–	ns	100	–	ns
t _r	Rise time of both SDA and SCL signals	–	1000	ns	–	300	ns
t _f	Fall time of both SDA and SCL signals	–	300	ns	–	300	ns
t _{SU,STO}	Set-up time for STOP condition	4.0	–	μs	0.6	–	μs
t _{BUF}	Bus free time between a STOP and START condition	4.7	–	μs	1.3	–	μs

8. RELIABILITY TEST

No.	Item	Description
01	High temperature operation	The sample should be allowed to stand at 70°C for 120 hours under driving condition and then returning it to normal temperature condition, and allowing it stand for 2 hours.
02	Low temperature operation	The sample should be allowed to stand at -20°C for 120 hours under driving condition and then returning it to normal temperature condition, and allowing it stand for 2 hours.
03	High temperature storage	The sample should be allowed to stand at 80°C for 240 hours under no-load condition, and then returning it to normal temperature condition, and allowing it stand for 2 hours.
04	Low temperature storage	The sample should be allowed to stand at -30°C for 240 hours under no-load condition, then returning it to normal temperature condition, and allowing it stand for 2 hours.
05	Moisture storage	The sample should be allowed to stand at 60°C,90%RH MAX for 240 hours under no-load condition, then taking it out and drying it at normal temperature for 2 hours.
06	Thermal shock storage	The sample should be allowed to stand the following 10 cycles : -30°C for 30 minutes → normal temperature for 5 minutes → +80°C for 30 minutes → normal temperature for 5 minutes, as one cycle.
07	Packing vibration	Frequency range : 10Hz ~ 55Hz Amplitude of vibration : 1.5mm Sweep time: 12 min X,Y,Z 2 hours for each direction.
08	Packing drop test	According to ASTM-D-5327.
09	Electrical Static Discharge	Air: ±4KV 150pF/330Ω 5 times
		Contact: ±2KV 150pF/330Ω 5 time

*Sample size for each test item is 3~5pcs

9. LCD MODULES HANDLING PRECAUTIONS

- The display panel is made of glass. Do not subject it to a mechanical shock by dropping it from a high place, etc.
- If the display panel is damaged and the liquid crystal substance inside it leaks out, do not get any in your mouth. If the substance come into contact with your skin or clothes promptly wash it off using soap and water.
- Do not apply excessive force to the display surface or the adjoining areas since this may cause the color tone to vary.
- The polarizer covering the display surface of the LCD module is soft and easily scratched. Handle this polarize carefully.
- To prevent destruction of the elements by static electricity, be careful to maintain an optimum work environment.
 - Be sure to ground the body when handling the LCD module.
 - Tools required for assembly, such as soldering irons, must be properly grounded.
 - To reduce the amount of static electricity generated, do not conduct assembly and other work under dry conditions.
 - The LCD module is coated with a film to protect the display surface. Exercise care when peeling off this protective film since static electricity may be generated.
- Storage precautions
When storing the LCD modules, avoid exposure to direct sunlight or to the light of fluorescent lamps. Keep the modules in bags designed to prevent static electricity charging under low temperature / normal humidity conditions (avoid high temperature / high humidity and low temperatures below 0°C). Whenever possible, the LCD modules should be stored in the same conditions in which they were shipped from our company.

10. OTHERS

- Liquid crystals solidify at low temperature (below the storage temperature range) leading to defective orientation of liquid crystal or the generation of air bubbles (black or white). Air bubbles may also be generated if the module is subjected to a strong shock at a low temperature.
- If the LCD modules have been operating for a long time showing the same display patterns may remain on the screen as ghost images and a slight contrast irregularity may also appear. Abnormal operating status can be resumed to be normal condition by suspending use for some time. It should be noted that this phenomena does not adversely affect performance reliability.
- To minimize the performance degradation of the LCD modules resulting from caused by static electricity, etc. exercise care to avoid holding the following sections when handling the modules:
 - Exposed area of the printed circuit board
 - Terminal electrode sections.