

The pilot operated directional valves 4D02V (NG10), 4D03 (NG16) and 4D06 (NG25) are offered under Denison brand name. The 4D02V is a high flow version with a maximum flow up to 170 l/min.

4D03 and 4D06 are based on the Parker D41 and D81 main stage with Denison 4D01 pilot valve.

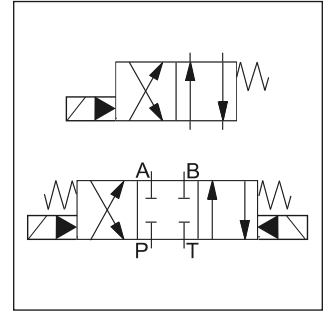

4D02V



4D03

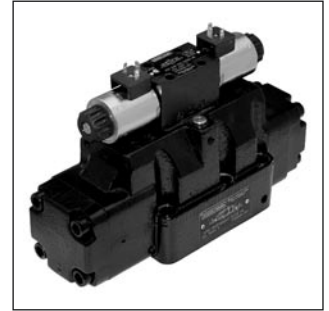

4D06

4D06

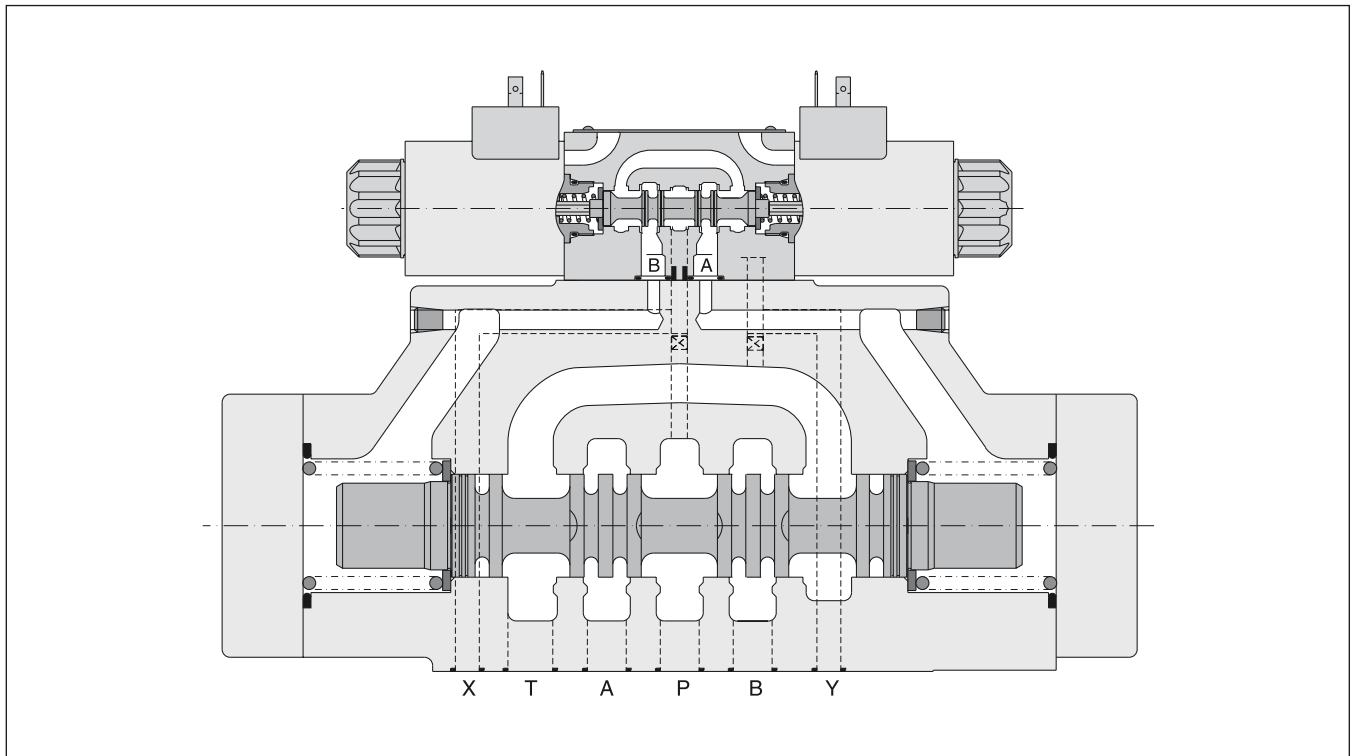

2

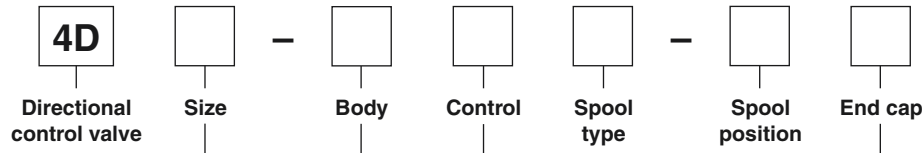

Code	Size
02	NG10
03	NG16
06	NG25

Code	Body
V	for 4D02
3	for 4D03/06

Code	Control
A	1 solenoid
B	2 solenoids
C	2 solenoids and 2 pos. detent pilot valve

3 position spools	
Code	Spool type
	a 0 b
01	
02	
03	
07	
08	
09	
10	
13	
14	
46	
55	
56	

2 position spools	
Code	Spool type
	a b
11	
51	

Code	End cap
03	Standard
09	With stroke adjustment on both sides

3 position spools		
Code	Spool position	
03		3 positions. Spring centered to "0".
05		2 positions. Spring centered to "0". Energized to "b".
06		2 positions. Spring centered to "0". Energized to "a".

2 position spools		
Code	Spool position	
01		2 positions. Spring offset to "b". Energized to "a".
02		2 positions. Spring offset to "a". Energized to "b".
04		2 positions detent. Operated in "a" or "b". No centre or spring offset position.

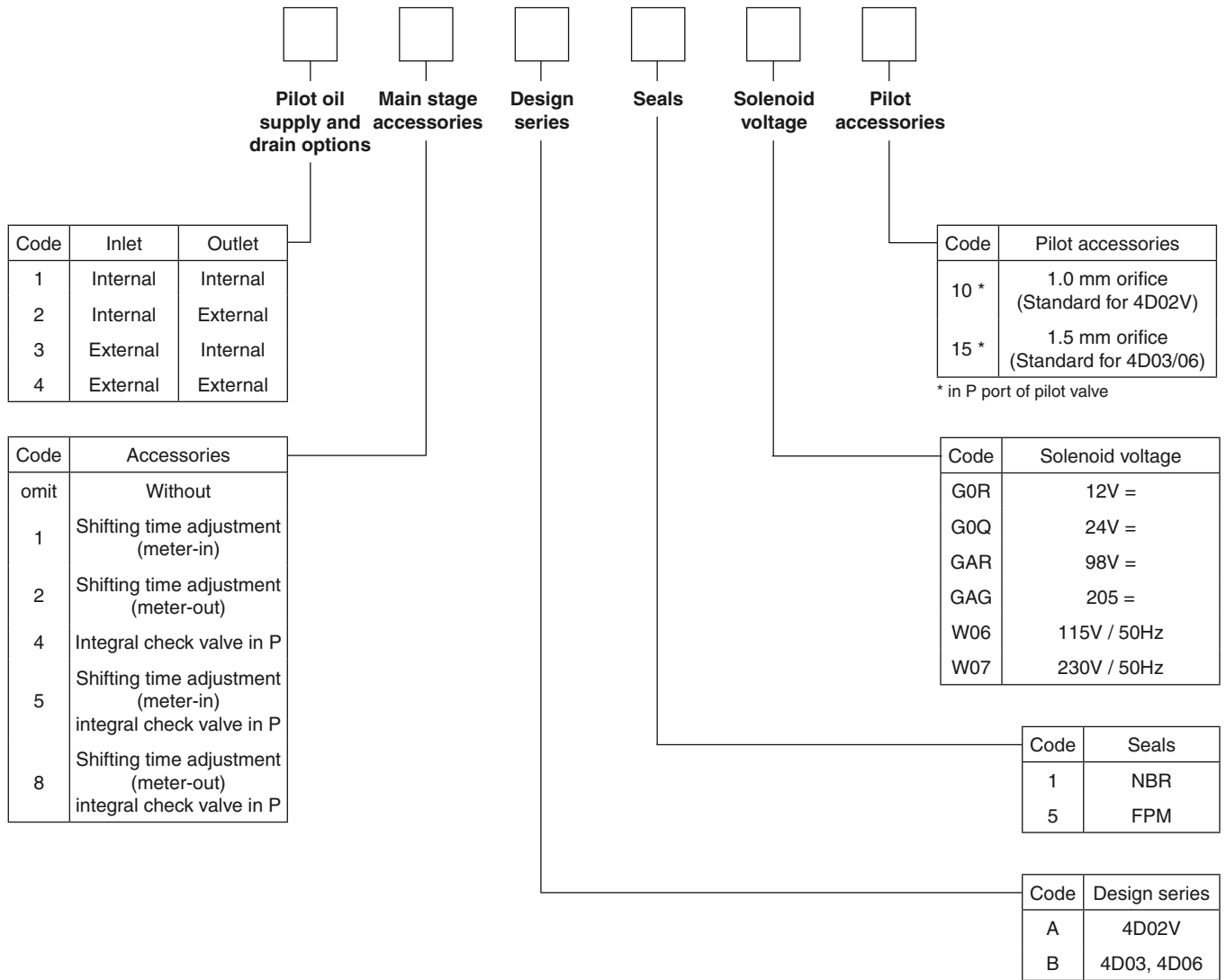

Further spool types, solenoid voltages, position control, hydraulic and mechanical operation on request.

2

General			Directional spool valve					
Design			Solenoid					
Actuation			Solenoid					
Series			4D02V		4D03	4D06		
Size			NG10		NG16	NG25		
Weight (1/ 2 solenoids) [kg]			7.6 / 8.1		9.6 / 9.9	17.8 / 18.2		
Mounting interface			DIN 24340 A10 ISO 4401 NFPA D05		DIN 24340 A16 ISO 4401 NFPA D07	DIN 24340 A25 ISO 4401 NFPA D08		
Mounting position			CETOP RP 121-H					
Ambient temperature [°C]			Unrestricted, preferably horizontal -20...+50					
Hydraulic			Pilot drain internal: P, A B, X: 350; T, Y: 105 (4D02V: P, A, B, X: 315; T, Y: 140) Pilot drain external: P, A B, T, X: 350; Y: 105 (4D02V: P, A, B: 315; T, X: 315; Y: 140) Hydraulic oil in accordance with DIN 51524 / 51525					
Max. operating pressure [bar]			Hydraulic oil in accordance with DIN 51524 / 51525					
Fluid			Hydraulic oil in accordance with DIN 51524 / 51525					
Fluid temperature [°C]			-20 ... +80					
Viscosity permitted [cSt] / [mm²/s]			10...650					
Viscosity recommended [cSt] / [mm²/s]			30					
Filtration			ISO 4406 (1999); 18/16/13 (meet NAS 1638: 7)					
Flow max. [l/min]			170		300	700		
Leakage at 350 bar (per flow path) [ml/min] *depending on spool			72...422		up to 200*	350...800		
Opening pressure integral check valve [bar]			n.a.		see p/Q diagram	see p/Q diagram		
Minimum pilot supply pressure [bar]			12 for spool with open centre position 13 for spool with closed centre position		5	5		
Static / Dynamic			Energized / De-energized					
Step response at 95% [ms]			Energized / De-energized					
DC solenoids Pilot pressure 50 bar			50 / 60		95 / 65	150 / 170		
100 bar			(150 bar) 50 / 60		75 / 65	110 / 170		
250 bar			50 / 50		60 / 65	90 / 170		
AC solenoids Pilot pressure 50 bar			30 / 50		75 / 55	130 / 155		
100 bar			(150 bar) 30 / 50		65 / 55	90 / 155		
250 bar			30 / 50		40 / 55	65 / 155		
Electrical characteristics			100% ED; CAUTION: coil temperature up to 180 °C possible IP 65 in accordance with EN 60529 (plugged and mounted)					
Duty ratio			100% ED; CAUTION: coil temperature up to 180 °C possible					
Protection class			IP 65 in accordance with EN 60529 (plugged and mounted)					
Code			G0R	G0Q	GAR	GAG	W06	W07
Supply voltage / ripple [V]			12 V =	24 V =	98 V =	205 V =	115V at 50Hz	230V at 50Hz/
Tolerance supply voltage [%]			+5...-10	±10	+5...-10	+5...-10	±5	±5
Power consumption hold [W]			31	31	31	31	264 VA	264 VA
Power consumption in rush [W]			31	31	31	31	264 VA	264 VA
Solenoid connection			Connector as per EN 175301-803, solenoid identification as per ISO 9461.					
Wiring min. [mm²]			3 x 1.5 recommended					
Wiring length max. [m]			50 recommended					

With electrical connections the protective conductor (PE ⚡) must be connected according to the relevant regulations.

The flow curve diagram shows the flow versus pressure drop curves for all spool types. The relevant curve number

for each spool type, operating position and flow direction is given in the table below.

4D02V

Spool Code	Curve number				
	P-A	P-B	P-T	A-T	B-T
01	3	3	7	4	3
02	3	3	—	2	4
03	3	3	—	2	5
07	4	6	6	4	10
08	2	3	—	4	4
09	2	2	—	1	4
10	2	3	—	4	4
11	5	3	—	2	5
13	2	4	—	1	4
14	4	3	—	2	4
46	8	9	—	7	9
51	6	4	—	3	6
55	—	7	—	8	—
56	4	—	—	9	—

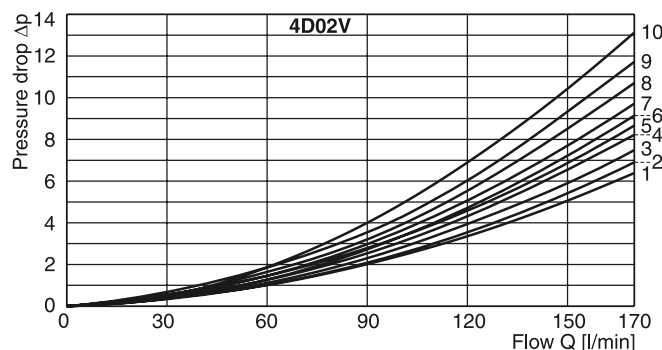

4D03

Spool Code	Curve number				
	P-A	P-B	P-T	A-T	B-T
01	1	2	6	4	6
02	1	1	—	4	5
03	1	1	—	4	5
07	2	9	8	7	10
08	1	1	—	5	5
09	1	2	—	4	6
10	1	2	—	5	6
11	2	3	—	6	7
13	2	2	—	3	5
14	2	2	—	3	5
46	1	2	—	3	6
51	3	5	—	3	5
55	2	8	—	2	—
56	8	2	—	—	3

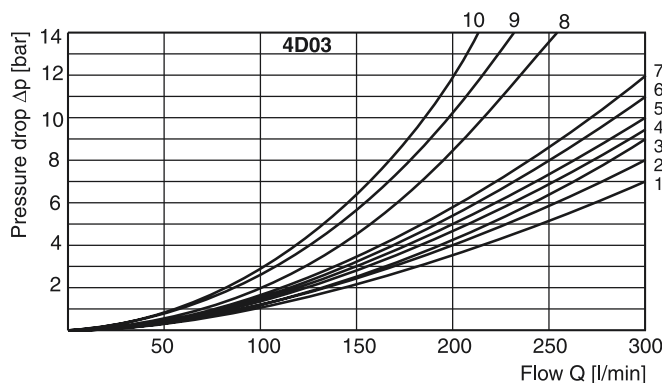

4D06

Spool Code	Curve number				
	P-A	P-B	P-T	A-T	B-T
01	2	1	1	3	5
02	3	2	—	3	5
03	3	2	—	3	5
07	4	8	9	4	10
08	4	3	—	3	5
09	3	3	—	4	5
10	4	2	—	3	6
11	3	2	—	3	5
13	1	2	—	4	5
14	3	3	—	4	5
46	2	2	—	4	6
51	6	5	—	6	8
55	5	10	—	3	—
56	10	5	—	—	5

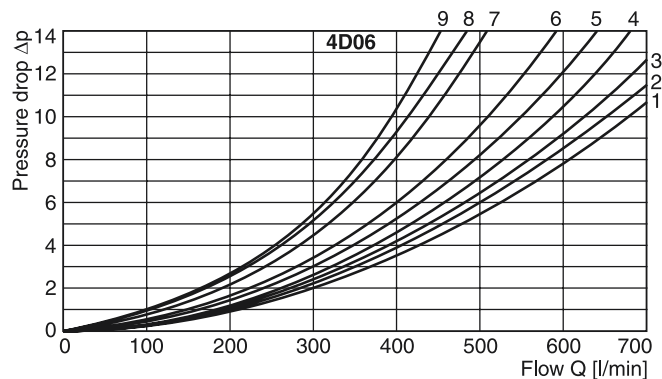

Integral check valve in the P port

Mounting an integral check valve in the P port is necessary to build up pilot pressure for valves with P to T connection and internal pilot oil supply. The pressure difference at the integral check valve (see performance curves)

is to be added to all flow curves of the P port of the main valve. Directional valves with an integral check valve are available for the series 4D02V, 4D03 and 4D06.

2

Flow curve 4D02V

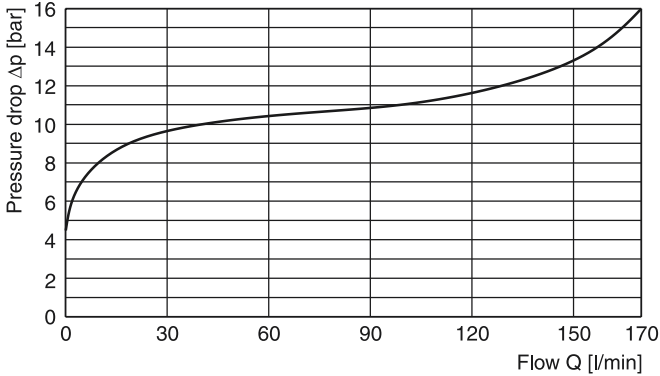

Flow curve 4D03

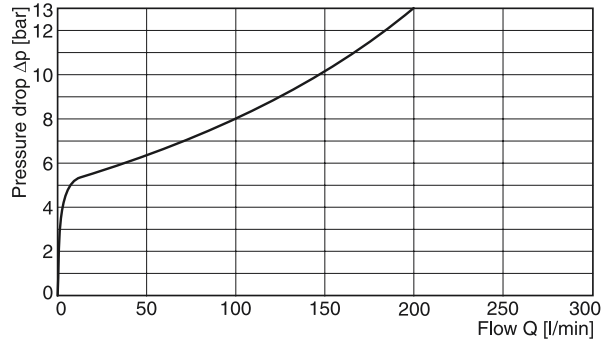

Flow curve 4D06

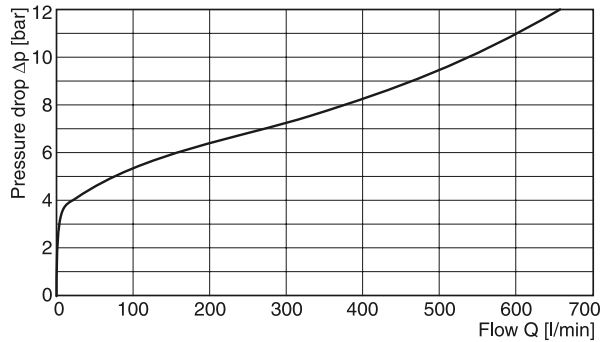

**Pilot oil inlet (supply) and outlet (drain)
Series 4D02V**

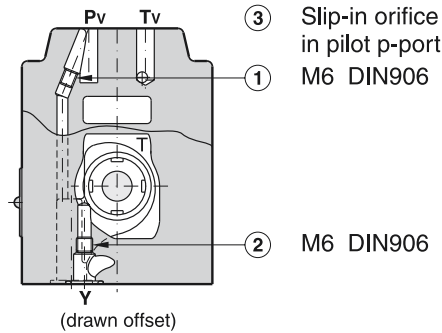

○ open, ● closed

Pilot oil		1	2	3
Inlet	Outlet			
internal	external	○	●	Orifice Ø1.0
external	external	●	●	Orifice Ø1.0
internal	internal	○	○	Orifice Ø1.0
external	internal	●	○	Orifice Ø1.0

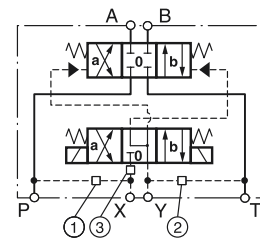

Series 4D03

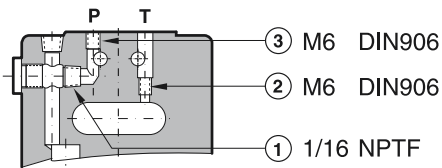

○ open, ● closed

Pilot oil		1	2	3
Inlet	Outlet			
internal	external	○	●	Orifice Ø1.5
external	external	●	●	Orifice Ø1.5
internal	internal	○	○	Orifice Ø1.5
external	internal	●	○	Orifice Ø1.5

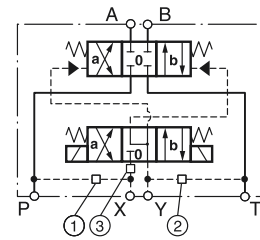

Series 4D06

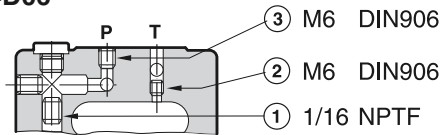

○ open, ● closed

Pilot oil		1	2	3
Inlet	Outlet			
internal	external	○	●	Orifice Ø1.5
external	external	●	●	Orifice Ø1.5
internal	internal	○	○	Orifice Ø1.5
external	internal	●	○	Orifice Ø1.5

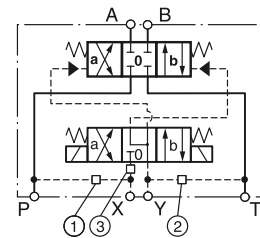

4D02V

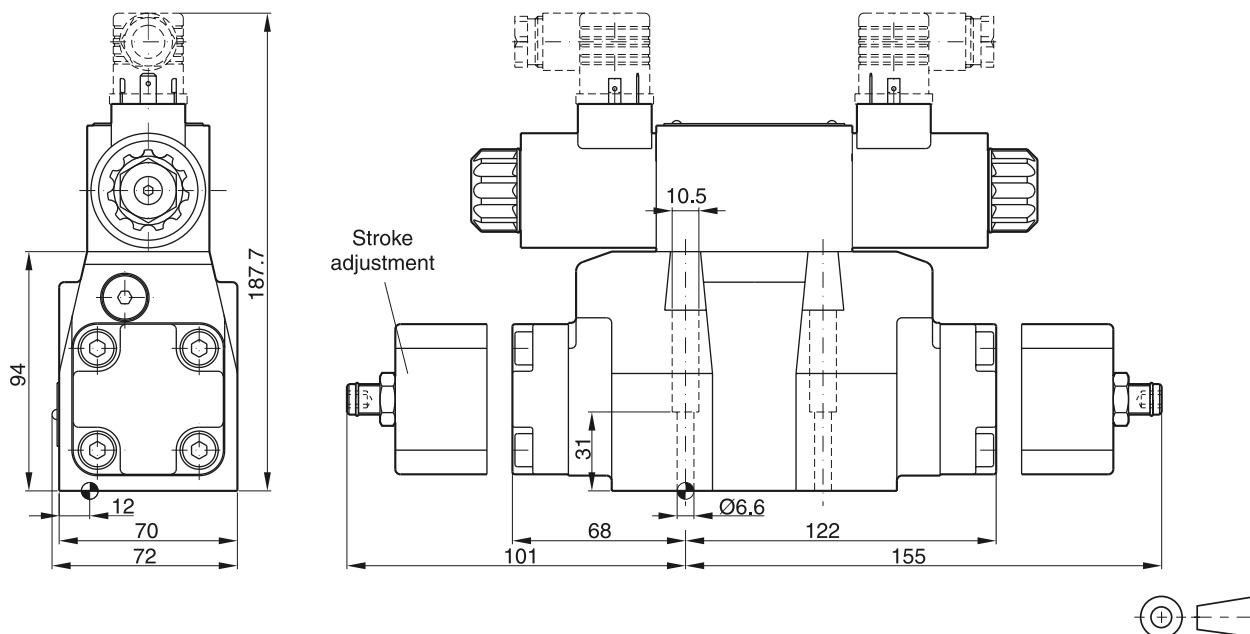

Surface finish	Kit	4x M6x40 DIN 912 12.9	13.2 Nm	Kit
	BK385			on request

4D03

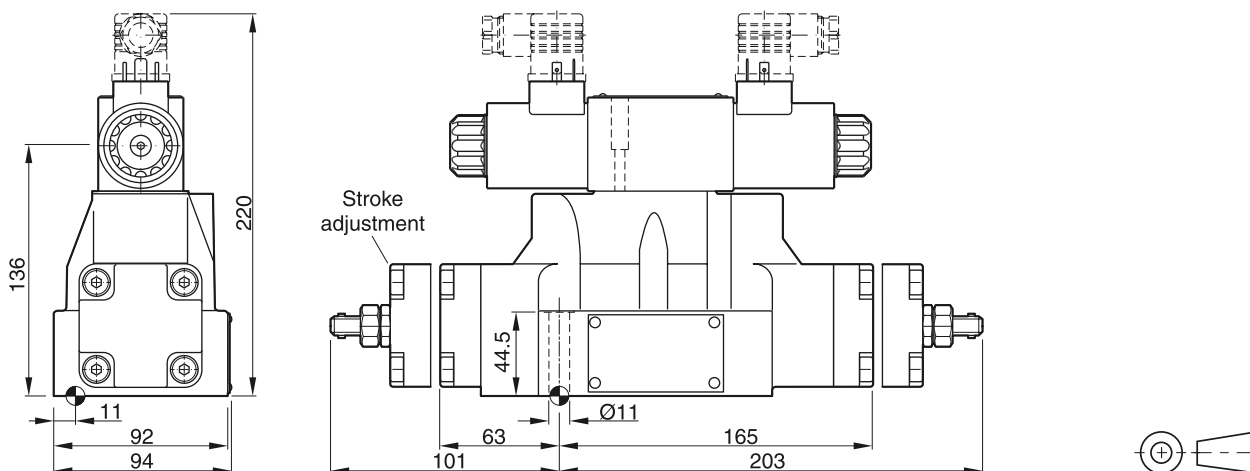





Surface finish	Kit	4x M10x50 2x M6x55 DIN 912 12.9	63 Nm ±15% 13.2 Nm ±15%	Kit
	BK320			on request

The space necessary to remove the plug as per EN 175301-803, design type AF is at least 15 mm.
 The torque for the screw M3 of the plug has to be 0.5 to 0.6 Nm.

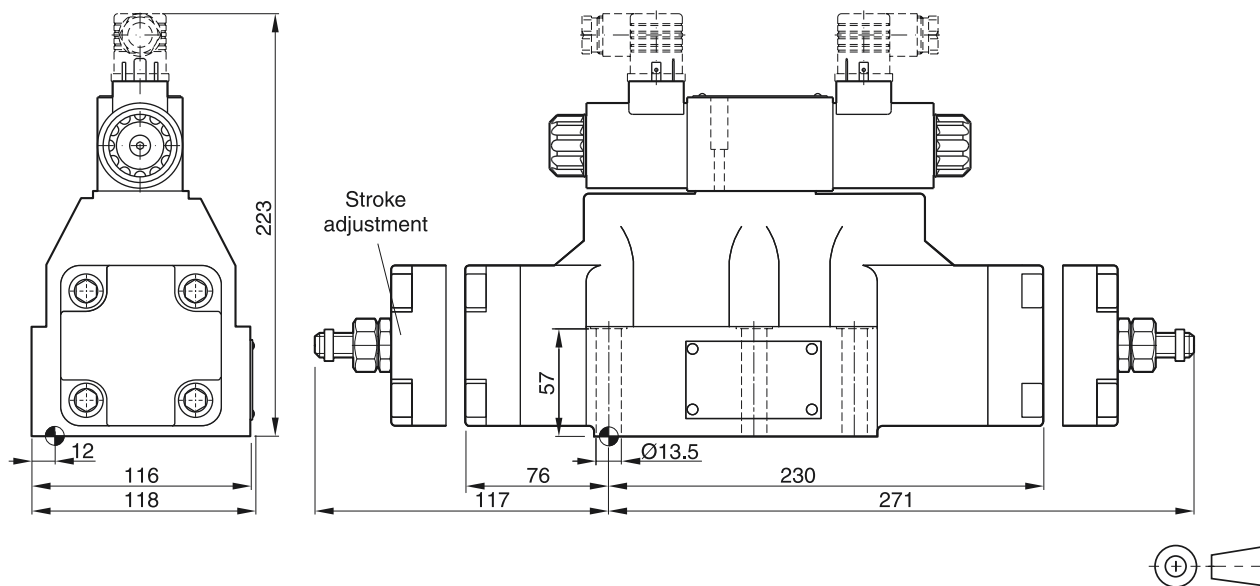
4D06

2

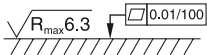

Surface finish	 Kit	 Kit	 Kit	 Kit
	BK360	6x M12x75 DIN 912 12.9	108 Nm ±15%	on request

The space necessary to remove the plug as per EN 175301-803, design type AF is at least 15 mm.
 The torque for the screw M3 of the plug has to be 0.5 to 0.6 Nm.