

Positioning Sensors · pneumatic

22800.0100



Product Description

Used in jigs and fixtures as positioning control for pre-machined workpieces. Sensitivity accuracy is 0.015-0.075 mm, depending on the workpiece surface. Contact control is achieved through compressed air backwash and is indicated on the monitoring unit.

Material

Seating Pins

- Tool steel, hardened, ground

Seal

- PVC

Screw

- Steel, zinc-plated by galvanization, quality 4.8 (ISO 1207)

Plug-in nipple

- Brass

More information

Notes

Further information on request.

Further products

- Monitoring Units, for positioning sensors, pneumatic

Drawing

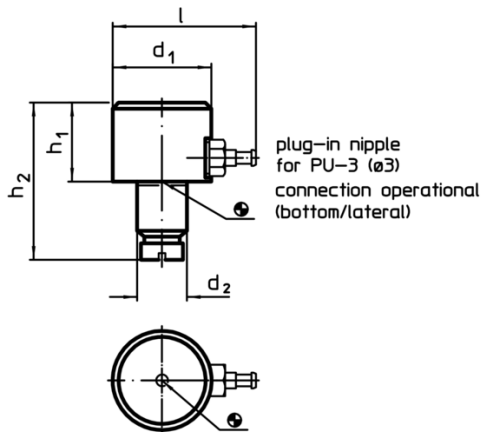

picture 1

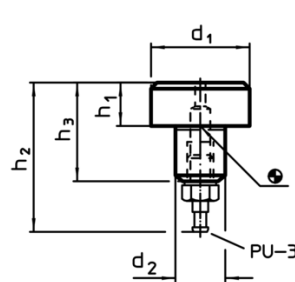

picture 2

Order information

Dimensions					[g]	Art. No.
d ₁	h ₁ h ₉	d ₂ n ₆	h ₂	h ₃		
bottom connection – picture 2						
16	5	8	28.5	15	12	22800.0100

Application example

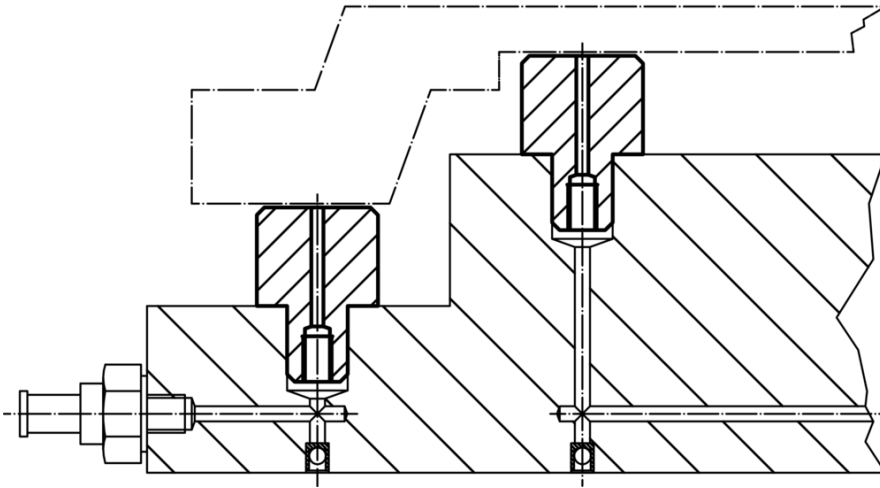

Compliance

RoHS compliant

Compliant according to Directive 2011/65/EU and Directive 2015/863

Does not contain SVHC substances

No SVHC substances with more than 0.1% w/w contained - SVHC list [REACH] as of 10.06.2022

Does not contain Proposition 65 substances

No Proposition 65 substances included
<https://www.P65Warnings.ca.gov/>

Free from Conflict Minerals

This product does not contain any substances designated as "conflict minerals" such as tantalum, tin, gold or tungsten from the Democratic Republic of Congo or adjacent countries.