

KNOB

Knurled anodised aluminium, black colour.

BASE

Black-oxide steel. Assembly by means of three holes for M5 cylindrical head screws with hexagon socket.

SCALE RING

Black anodised matte aluminium.

Assembly to the bushing by means of two countersunk head screws.

INTERNAL LOCKING MECHANISM

Ground and hardened steel.

STANDARD EXECUTIONS

Steel bushing. H7 reamed hole and keyway in compliance with DIN 6885/2 tolerance P9 (see page A-15). Assembly to the spindle by means of a keyway or a transversal pin.

- **GN 700-A:** base with triangular index, ring with indexing line.
- **GN 700-B:** plain base and ring.
- **GN 700-S:** base with triangular index, ring with standard graduation, 100 marks, numbering from 0 to 9 increases as the knob is turned clockwise.

In GN 700-A and GN 700-S the triangular index is marked exactly in the middle, at the same distance from the base assembly holes (60°).

FEATURES AND APPLICATIONS

GN 700 locking and continuous control indexing mechanisms are used to control machine spindles for clockwise and anti-clockwise rotation and to keep the spindle in a given position even when vibrations or torque make it turn. Therefore, the locking system prevents the spindle from making uncontrolled movements and offers enhanced safety protection against rotation. The locking system, which operates on the principle of the two directional free wheel with lock, is used to transmit the movement without clearance in both directions.

This locking and continuous control knob cannot be used where the spindle rotates before the adjustment is performed or as a bearing for the controlled spindle or in case of high-intensity vibrations.

SPECIAL EXECUTIONS ON REQUEST

Graduations other (see page 611).

INSTRUCTIONS

By turning the control knob, one of the two release-pins (depending on the rotation direction) pushes the stop cylinder against the central spring into an inactive position that allows the bushing and therefore the spindle to rotate freely.

The second release-pin limits the movement of the other stop cylinder and, at the same time, ensures that the bushing is driven and rotated with precision while the first pin remains in the inactive position until the rotation ends, when the spring resets the lock.

The scale ring, connected to the assembly hole, accurately positions the machine spindle. Thus, infinite adjustments can be performed to cover all operating requirements.

ASSEMBLY INSTRUCTIONS

To ensure perfect operation of the GN 700 element, the base should be assembled exactly perpendicular to the spindle axis.



design94
stuttgart
if
Hannover 92

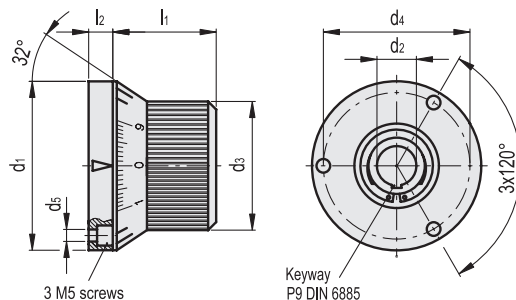
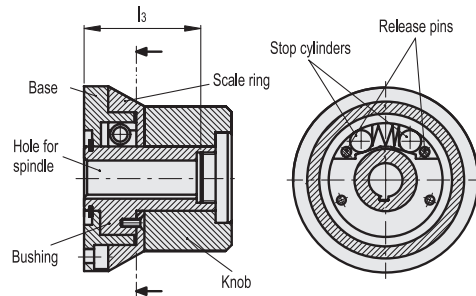

Code	Description	d1	d2 H7	d5	d3	d4-0.2	l1	l2	l3	⚖
GN.25001	GN 700-66-K12-A	66	12	5.5	52	55	44	9	40	572
GN.25011	GN 700-66-K12-B	66	12	5.5	52	55	44	9	40	572
GN.25021	GN 700-66-K12-S	66	12	5.5	52	55	44	9	40	572