

Ball Casters · plain bearing

22753.0065



Product Description

Ball casters are module for transport systems, conveyances, to working and packing facilities. For example, parts can be easily moved, turned and controlled. The ball casters are maintenance-free. At temperatures > 20°C, the carrying figure decreases linearly. (Example: at 90°C the load bearing capacity is max. 60%)

Material

Housing

- stainless steel

Bearing

- plastic

Ball

- Stainless steel, hardened

Assembly

Locking in place is achieved by pressing-in the knurled contour ball caster. Ball casters can be mounted from the functional side, using the assembly tool.

Knurling on the external contour allows installation into bore holes without additional preparatory steps.

Drawing

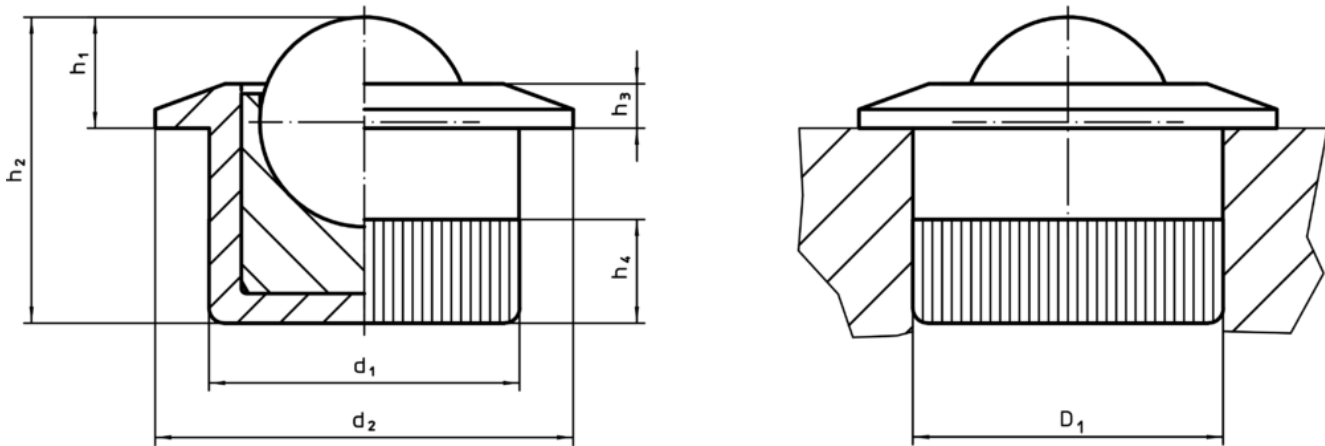

Order information

| d <sub>1</sub> | ball diameter | Dimensions     |                        |                |                |                | Location hole<br>D <sub>1</sub><br>H7<br>[mm] | static carrying<br>figure C <sub>0</sub><br>[N] | Temperature |              | Weight<br>[g] | Art. No.   |
|----------------|---------------|----------------|------------------------|----------------|----------------|----------------|---|---|-------------|--------------|---------------|------------|
|                |               | d <sub>2</sub> | h <sub>1</sub><br>[mm] | h <sub>2</sub> | h <sub>3</sub> | h <sub>4</sub> |   |   | min.        | max.<br>[°C] |               |            |
| 10             | 6.5           | 13             | 3.2                    | 11.2           | 1.2            | 4.2            | 10  | 1161  | -50         | 90           | 4.1           | 22753.0065 |

Accessories

| Assembly Tool | Suitable for ball caster |  | Weight<br>[g] | Art. No.   |
|---------------|--------------------------|--|---------------|------------|
|               | [mm]                     |  |               |            |
|               | 10.0                     |  | 118           | 22753.9965 |
|               | 12.6                     |  | 125           | 22753.9985 |

## Compliance

### RoHS compliant

Compliant according to Directive 2011/65/EU and Directive 2015/863

### Does not contain SVHC substances

No SVHC substances with more than 0.1% w/w contained - SVHC list [REACH] as of 10.06.2022

### Does not contain Proposition 65 substances

No Proposition 65 substances included  
<https://www.P65Warnings.ca.gov/>

### Free from Conflict Minerals

This product does not contain any substances designated as "conflict minerals" such as tantalum, tin, gold or tungsten from the Democratic Republic of Congo or adjacent countries.