

DO NOT SCALE DRAWING

REVISION

A INITIAL DRAWING 25.01.16

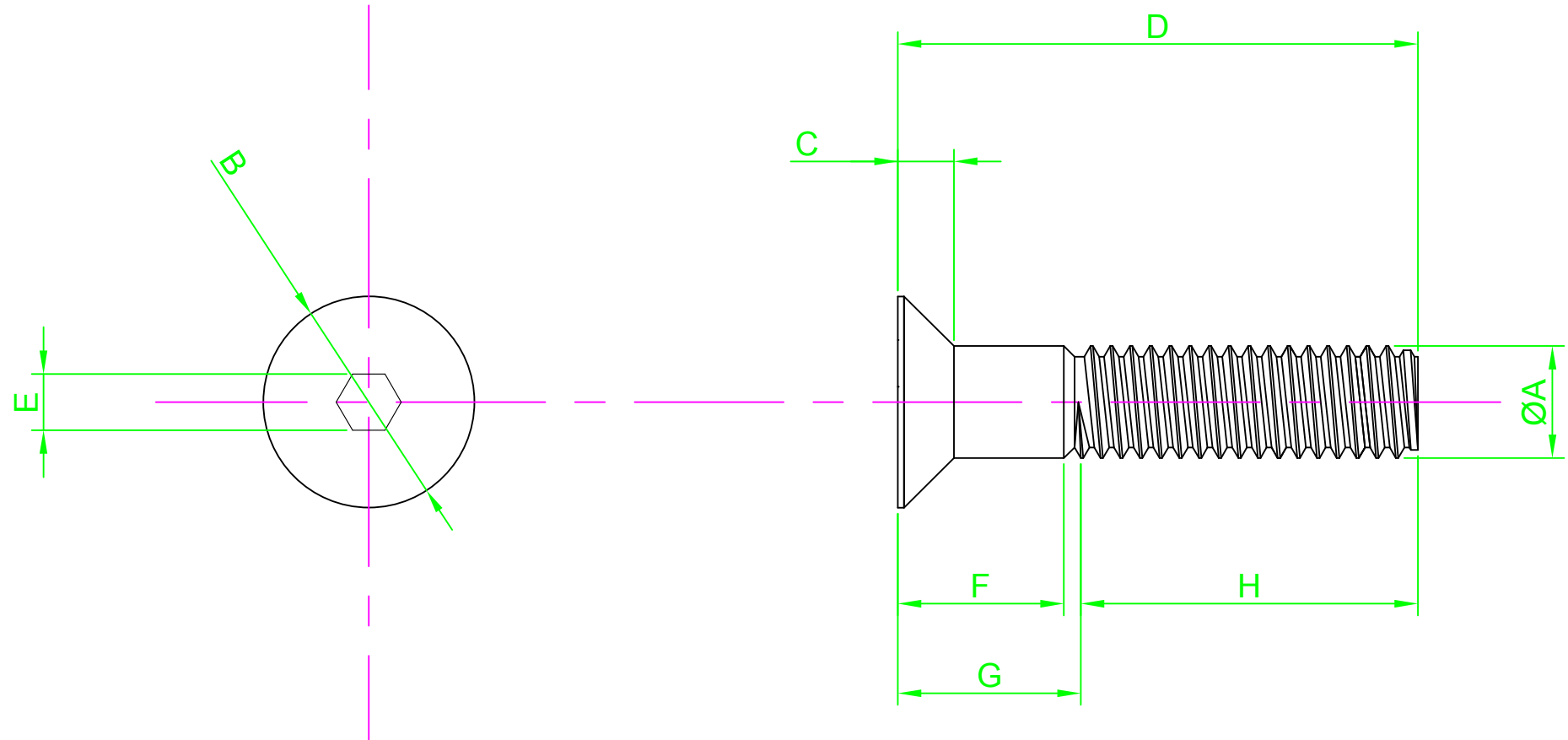

Part Number	ØA	B Nom	C Max	D Length	E Nom	F Min	G Max	H Ref
M4 20 KH10MC S50	M4-0.7	8.0	2.3	20.0	2.5	N/A	4.40	N/A
M4 25 KH10MC S50				25.0				
M6 30 KH10MC S50	M6-1.0	12	3.3	30.0	4.0	N/A	6.30	18.0
M6 40 KH10MC S50				40.0				
M6 50 KH10MC S50				50.0				
M8 20 KH10MC S50	M4-0.7	16.0	4.4	20.0	5.0	N/A	8.20	N/A
M8 30 KH10MC S50				30.0				
M8 35 KH10MC S50				35.0				
M8 40 KH10MC S50				40.0				
M8 50 KH10MC S50				50.0				
M8 60 KH10MC S50				60.0				
						21.7	28.0	22.0
						31.7	38.0	

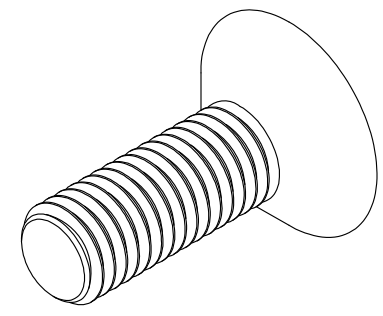

NOTES:



UNLESS OTHERWISE SPECIFIED:
DIMENSIONS ARE IN MM (MILLIMETERS).
SURFACE FINISH:
TOLERANCES: DIN 7991

MATERIAL:
Steel

TITLE:
Hex Socket Csk Head Cap Screw DIN 7991

	NAME	DATE
DRAWN	Darryl Wilson	25.01.16
CHK'D		
APPVD		

HEAT TREATMENT:
Grade 10.9

DESIGN RIGHT. TR FASTENINGS LTD, 2003
UNDER NO CIRCUMSTANCES MUST THIS
DRAWING BE COPIED OR DISCLOSED
WITHOUT FIRST OBTAINING WRITTEN
AUTHORITY.

CUSTOMER PART NUMBER:
N/A

FINISH:
Self Finish

DRAWING NUMBER:
TR32KH10MCS50

A4

