

- > **Energy at 5,5 bar operating pressure
24,5 ... 253 Joule**
- > **High energy output**
- > **Ideally suited to a wide range of marking, piercing and light presswork applications**
- > **Rugged, corrosion-resistant construction**



Technical features

Operation:

For a fraction of the capital outlay, the Impact Cylinder provides a power unit capable of carrying out an infinite variety of presswork applications traditionally performed by flypresses, kickpresses, drop stampings, crankpresses, etc. In fact many applications benefit from Impact working, as the high tool velocity and rate of energy application can produce results such as cleaner edges when cutting, and improved grain structure when forging.

The construction and principle of operation is extremely simple, inherently giving reliability and long life, the only moving part being the piston rod assembly.

Coupled to simple control circuit, an Impact Cylinder will operate from a normal factory air line, and can either be mounted on a suitable frame to form a self-contained press, or built in to form part of a special purpose machine, and pneumatically interlocked with automatic feed and eject mechanisms. For special purpose applications or to double up on

energy output, two Impact Cylinders can be used vertically in opposition, and operated together. With this arrangement reaction in the framework is neutralised and the velocity is doubled.

Operating pressure:

2,7 ... 10 bar (39 ... 145 psi)
M/3060 2 ... 10 bar (29 ... 145 psi)

Operating temperature:

-20 to +80°C max. (-4 ... +176°F)

Consult our Technical Service for use below +5°C (+41°F)

Mounting position:

Vertical

Materials:

Rear end cover: Aluminium
Front end cover: Aluminium or steel
Piston: Steel
Piston rod: Hardened steel
Centre piece: Aluminium or steel
Seals: NBR

Technical data

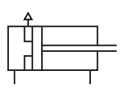
Symbol	Ø Cylinder	Max. cycle per minute	Energy at 5,5 bar (Joule)	Air consumption at 5,5 bar operating pressure (l/cycle)	Max. recommended weight to be carried vertically by the piston rod (kg)	Weight (kg)	Model
	2 inch	60	24,5	5,7	3,6	3,5	M/3020M
	3 inch	50	63	12,8	9,0	7,7	M/3030M
	4 inch	40	125,5	22,8	15,8	11,4	M/3040M
	6 inch	35	253	51,3	36,2	32,6	M/3060

Important

For all applications complete guarding must be incorporated, either fixed or interlocked with the control circuit. For further information consult Norgren technical sales.

An Impact Cylinder gives an output rated in energy i.e. thrust x distance. This energy is by rapidly accelerating the piston rod and tool assembly over a free stroke of approximately 65 mm, before contacting the work. The rapid is produced by the differential area arrangement which exposes

the full area of the piston to high pressure air built up in the reservoir at rear end of the cylinder.

It is of vital importance that the impact cylinder is NEVER allowed to fully stroke (extend) during operation. Following the point of impact, the tooling design should incorporate a mechanical stop preventing this action from taking place.

Failure of the unit could occur as a direct result of this being ignored.

Option selector

M/30★★★

Cylinder ø	Substitute
2 inch	20M
3 inch	30M
4 inch	40M
6 inch	60

The energy output from an impact cylinder can be controlled by adjusting the air pressure. The graph on the right shows in principle how the output is achieved as a percentage of the total energy by variations in air pressure. The point of stroke giving maximum energy corresponds to the highest point on the appropriate pressure curve. This is the point of the stroke at the tool should contact the component.

For normal factory airline pressures ranging from 4 ... 7 bar this contact point can be said to occur anywhere between 50 and 75 mm. If the impact cylinder requires only to effect an application, this means that a unit of the next smaller size will be powerful enough at the rated pressure. If an impact cylinder is being used for a number of and the maximum pressure of is still too powerful, then the energy given can be further reduced by decreasing the contact point to perhaps 25 mm or less. Alternatively a special circuit will allow operation.

Operating pressure

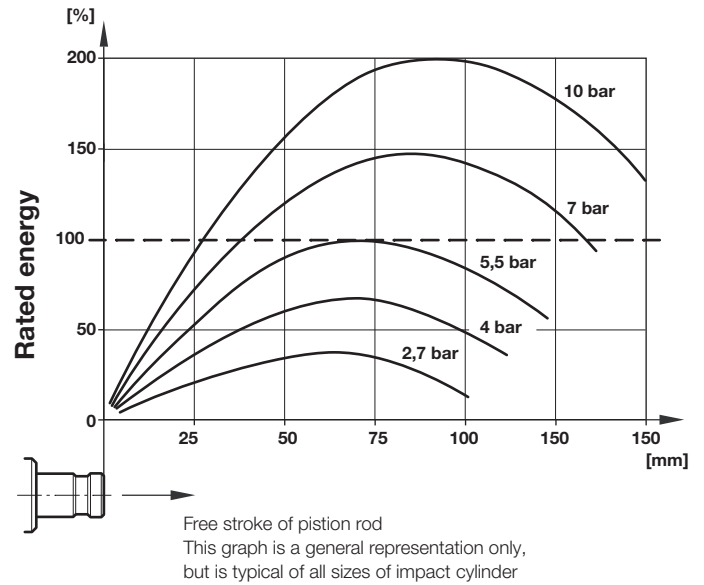

Mountings

Model B, G



Ø	
2 inch	QM/871
3 inch	QM/984
4 inch	QM/987
6 inch	QM/990

Dimensions

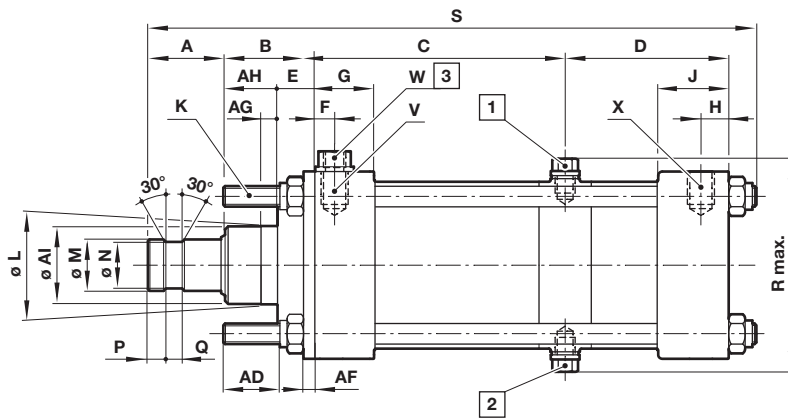

M/3020M
M/3060

M/3030M
M/3040M

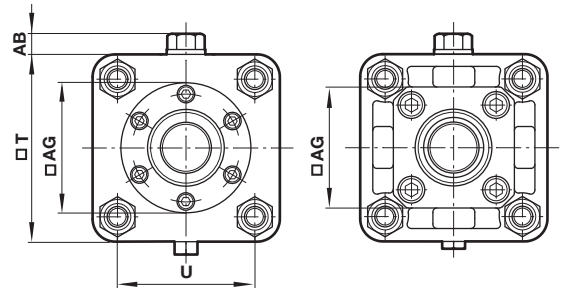

- 1 Plug
- 2 Orifice plug as supplied, but
Can be reserved if desired
- 3 M/3060 with adaptor fitted

Ø	A	B	C	D	E	F	G	H	J	K	Ø L
2 inch	37,5	35	279	103	14,3	9,5	24	9,5	24	M 8	31,72/31,67
3 inch	37,5	38	299	121,4	12,7	13,5	35	13,5	35	M 10	38,07/38,02
4 inch	44,5	44,5	297	117,5	12,7	13,5	35	13,5	35	M 11	44,42/44,37
6 inch	63,5	68	302	132	15,9	24	43	18,5	41	M 16	69,82/69,75
Ø	Ø M	Ø N	P	Q	R max.	S	T	U	V	W	X
2 inch	20	17,5	9,5	6	76	461	63,5	48	G 1/4	-	G 1/4
3 inch	25	23	9	8	103	506	89	67	G 3/8	-	G 3/8
4 inch	32	28,5	11	9,5	129	516	114	89	G 3/8	-	G 3/8
6 inch	44,5	40,5	19	12,5	181	587	167	129	-	G 1/2	G 1/2
Ø	AB	AC	AD	AF	AG	AH	AI	kg	Model		
2 inch	0	Ø 40	17	5,5	8	20,5	31,5	3,5	M/3020M		
3 inch	0	... 60	27,5	-	8	25,5	37,5	7,7	M/3030M		
4 inch	0	... 62,5	34,5	-	8	31,5	44	11,4	M/3040M		
6 inch	10	Ø 127	48	-	9,5	35	69,5	33,3	M/3060		

Rear flange B, front flange G

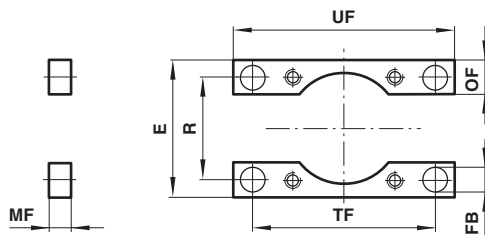

Ø	E	FB	MF	OF	R	TF	UF	kg	Model
2 inch	64	9	10	16	47,5	86	104	0,2	QM/871
3 inch	114	11	15	25	66,5	112	134	0,45	QM/984
4 inch	121	14	16	32	89	146	178	1	QM/987
6 inch	114	17	20	40	128,5	204	242	2,4	QM/990

Warning

These products are intended for use in industrial compressed air systems only. Do not use these products where pressures and temperatures can exceed those listed under

»Technical features/data«.

Before using these products with fluids other than those specified, for non-industrial applications, life-support systems or other applications not within published specifications, consult IMI NORGREN.

Through misuse, age, or malfunction, components used in fluid power systems can fail in various modes.

The system designer is warned to consider the failure modes of all component parts used in fluid power systems and to provide adequate safeguards to prevent personal injury or damage to equipment in the event of such failure.

System designers must provide a warning to end users in the system instructional manual if protection against a failure mode cannot be adequately provided.

System designers and end users are cautioned to review specific warnings found in instruction sheets packed and shipped with these products.