

FELLER GMBH

A-2525 GUENSELSDORF, AUSTRIA - TEL.: .. 43(2256) 62 32 50 - FAX: .. 43 (2256) 62 32 57
e-mail: sales@feller-at.com <http://www.feller-at.com>

Description: C14G-H05Z1Z1F3G100-C13W/3,00M WS9010

Rating of cord set: 10A/250Vac

1. PLUG: Type C14G (HALOGENFREE)

Interconnection coupler according to : EN/IEC 60320-2-2/E
Rated current and voltage : 10 A, 250 V AC
Plugbase : PPO GFR
Pins : solid brass, nickel-plated, crimped
Pins dimension : 4,00mm x 2,00mm
Outer mold : TPE-S, hardness Shore A 78-82
Approvals : ÖVE

2. CORD: Type H05Z1Z1F3G1,00 mm² (HALOGENFREE) WHITE RAL9010

Flexible cord according to : HD21.14 S1, ÖVE E8241-14
Marked : *JF*<ÖVE><HAR>H05Z1Z1F3G1,0mm2*HFFR*CE OR
xxx<VDE>*<HAR>*H05Z1Z1-F HFFR
Number of cores : 3
Conductor construction : 23 X 0,20 mm O.D. 1,10 mm
Conductor insulation : Extruded TI6, O.D. 2,40 mm +/- 0,05mm
Jacket : Extruded TM7, O.D. 6,80 mm +/- 0,20mm
Resistance of conductors : max. 26 Ω /km
Dielectric strength : 2kVac, 1min.
Insulation resistance : >0,010M Ω /km
Color of conductors : yellow/green, brown, blue
Approvals : HARMONIZED, ÖVE/VDE

3. CONNECTOR: Type C13W (HALOGENFREE)

Molded connector according to : EN/IEC 60320/C13
Rated current and voltage : 10 A, 250 V AC
Construction : double insulation
Contacts of the connection : self-adjusting phosphor bronze CuSn6
Inner insulation : PPO GFR
Outer mold : TPE-S hardness Shore A 78-82
Approvals : CE

Environmental conformity : EU-Directive 2012/19/EU (WEEE)
EU-Directive 2011/65/EU
EU-Directive 1907/2006 EG (REACH -compliant)

TESTING

Electrical testing : 100%
Visual inspection : 100%
High pot test wire to wire : 3kVac for 2 sec.
Continuity test : 25Aac to grounding / 20Aac to line and neutral
Polarity test : yes
Skin high pot test : 6kVac line to skin

design subject to change without prior notice, except written agreements with customer

DATE of ISSUE:	November, 2017		
REV: 1	1	ORIG:	DG

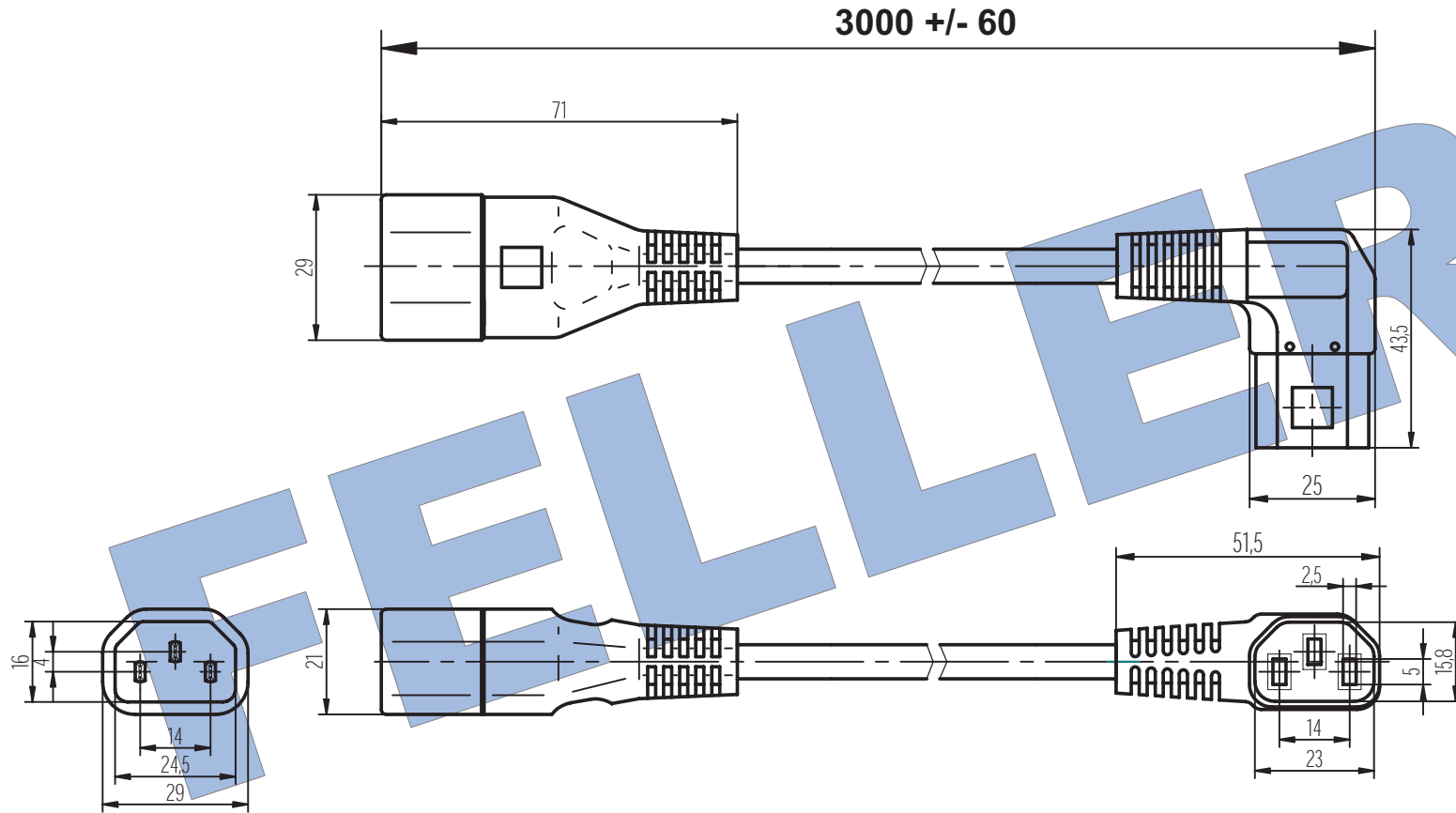

1.
C14G

2.
H05Z1Z1F3G1,00

3.
C13W

Feller Type: C14G-H05Z1Z1F3G100-C13W/3,00M WS9010

FELLER 

PN: 88F4108

All dimensions in mm
RoHS compliant

A-2525 Günselsdorf, Austria
Telefon 0043-2256-62325-0
Fax: 0043-2256-62325-7
email: sales@feller-at.com
<http://www.feller-at.com>

23.11.2017 | **DG**