

- 1
- 2
- 3
- 4
- 5
- 6
- 7
- 8
- 9
- 10
- 11
- 12
- 13
- 14
- 15
- 16
- 17
- 18

MATERIAL

Glass-fibre reinforced polypropylene based (PP) technopolymer, black colour, matte finish.

BOSS CAP

- ECB.I: polyester based technopolymer (PBT) in Elecolors colours, glossy finish, press-fit assembly. Supplied.
Available also as accessory sold separately (see table).

STANDARD EXECUTION

Black-oxide steel boss, H7 reamed hole.
Revolving handle EBS+x (see page375) in technopolymer, not removable.

SPECIAL EXECUTIONS ON REQUEST

Bosses with hole and keyway in compliance with DIN 6885/1 tolerance P9 (see page A-16).

To order the handwheel with keyway add the index -K after the code and the description (i.e. 208311-K- EYK.400+EBS A-20-K-).

For sufficient quantities: executions with locking device (Elesa patent) (see page 128).

The three-arm handwheels can be customised with marks, logo or special graphics (tampoprinting). The handwheels or handles can be supplied also in special coloured technopolymer.

ERGONOMY AND DESIGN

The three equidistant arms (120°) offer a perfect grip and the greatest operational easiness, also to disabled people. The rounded lines, the special compact and ergonomic shape of EYK. handwheel design together with the absence of cavities offer an excellent level of safety for hands during the steering operations.

ACCESSORIES ON REQUEST

- GN 184: axial retaining washer in black-oxide steel (see page 897).
- ECB.I: boss cap in polyester based technopolymer (PBT) in Elecolors colours, glossy finish, press-fit assembly (see table).



ERGOSTYLE® ELESA Original design

- C1
RAL7021
- C2
RAL2004
- C3
RAL7035
- C4
RAL1021
- C5
RAL5024
- C6
RAL3000

ECB.I

Code	Description	Boss cap for
29451-*	ECB.I3-*	EYK.275/401

* Complete with colour index (C1, ..., C6).

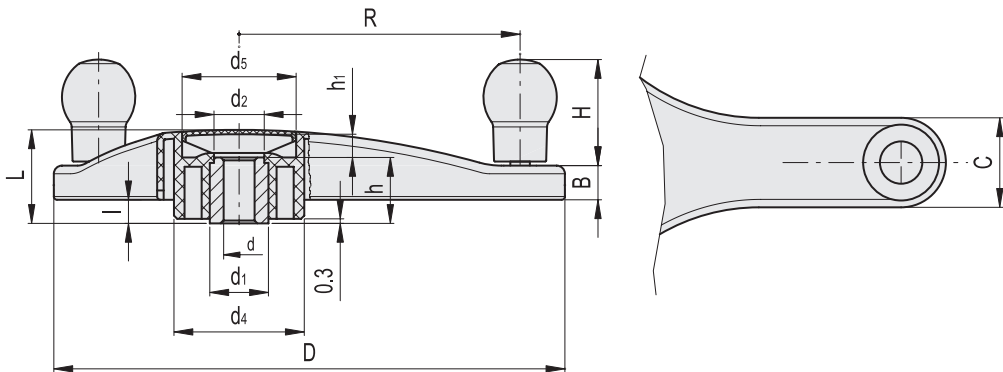

- * Complete with colour index, example: 208111-C2 EYK.275+I A-20-C2
- C1
RAL7021
 - C2
RAL2004
 - C3
RAL7035
 - C4
RAL1021
 - C5
RAL5024
 - C6
RAL3000

Code	Description	D	dH7	L	B	d1	d2	d4	d5	h	h1	l	C	H	R	C# [Nm]	L# [J]	Δ
208111-*	EYK.275+EBS A-20-*	275	20	54	21	35	33	76	70	38	14	19.5	50	65	112.5	270	12	769
208311-*	EYK.400+EBS A-20-*	400	20	54	21	35	33	80	70	38	14	12	55	65	172.5	270	16	955