

Face milling cutters, 45°

For indexable milling inserts: SAHT 1306..

ATORN®

Application

For machining stainless steels and other long-chipping materials. For face milling, chamfering, rough machining and finishing.

Version

- Wear-resistant, nickel-plated version
- With robust support design
- Clamping screw tightening torque (indexable insert) M5 = 8 Nm

Advantage

- Particularly smooth cut and low noise generation
- Safe chip removal due to helical chips
- Indexable insert with sharp blade particularly suited to milling VA

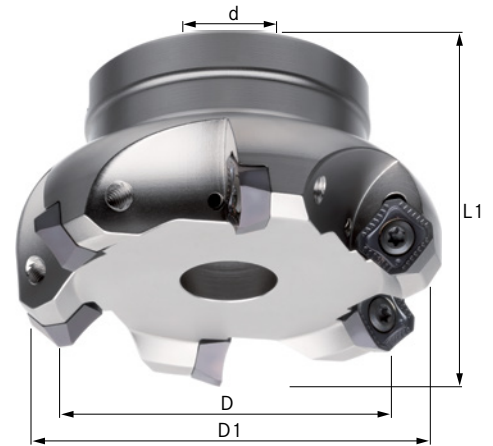

Art. No.	16025 200
Min. cutting edge diameter	100 mm
Max. cutting edge diameter	111 mm
Length	50 mm
Bore diameter	32 mm
max. ap	6 mm
Number of cutting edges	7 PCS

EAN-Code

4050293538854