

Small Geared Motors GE/I with DC Motor

General data: Light model range, extremely high ratios.

Housing: Aluminium die-cast, sealed against lubricant leaks and protected against dust, can be mounted in any position.

Gearing: Depending on the arrangement of the gear stages milled from high-grade plastic or steel.

Bearing system: Motor: roller bearing. Gearbox: sintered bronze slide bearing.

Lubrication: Maintenance free grease lubrication.

Motor: Brushed DC motor for 12 Volt or 24 Volt. Pinion pressed onto motor shaft. Free lead ends. Sense of rotation can be changed by swopping leads over.

Protection class IP 21. Insulation class E. Operation mode S1.

Please note: At continuous operation the motor heats up to 50 to 60°C.

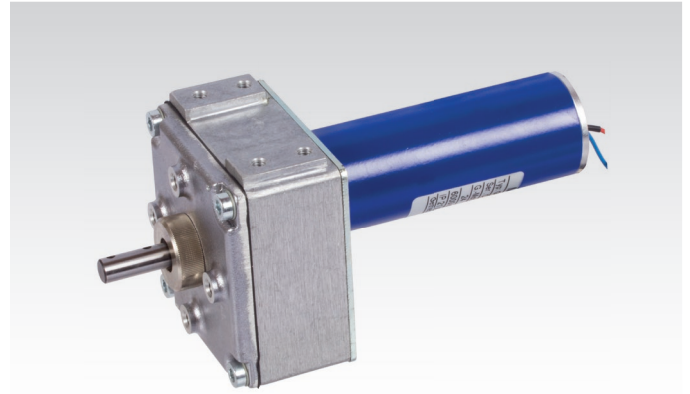

Ordering details: e.g.: Type,

Product No. DC Motor

Product No. Gearbox

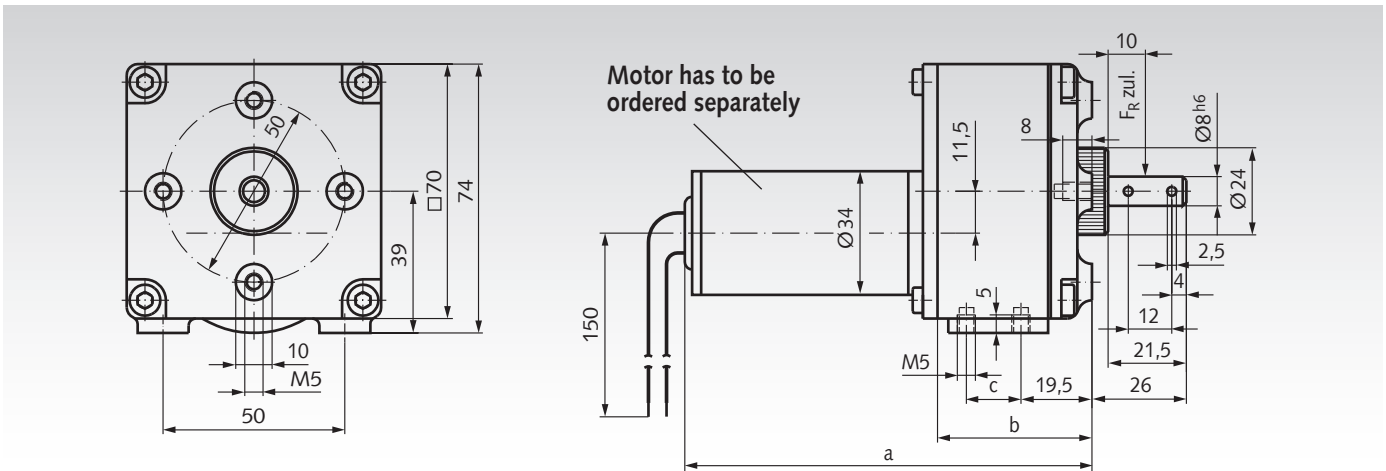

DC motor 12 Volt: Product No. 430 403 00

DC motor 24 Volt: Product No. 430 405 00. Weight 0.33 kg

Motor and gearbox have to be ordered separately.

Gearbox Product No.	Output Speed Relating to Motor speed 6000 min ⁻¹	Ratio i	max. continous Torque Ncm	max. starting Torque Ncm	Nominal Power Watt	Gearbox Efficiency %	Dimensions			Weight Gearbox kg
							a mm	b mm	c mm	
430 301 01	400	15 : 1	30	40	13	77	138,5	42,5	15	0,3
430 302 01	200	30 : 1	42	65	8,8	69	138,5	42,5	15	0,3
430 303 01	134	45 : 1	62	90	8,7	69	138,5	42,5	15	0,3
430 304 01	100	60 : 1	70	120	7,3	65	138,5	42,5	15	0,3
430 305 01	67	90 : 1	100	180	7,0	65	138,5	42,5	15	0,3
430 306 01	50	120 : 1	130	230	6,8	60	138,5	42,5	15	0,3
430 307 01	44	135 : 1	150	260	7,0	60	138,5	42,5	15	0,3
430 308 01	33	180 : 1	150	260	5,2	55	138,5	42,5	15	0,3
430 309 01	25	240 : 1	200	300	5,2	55	152,5	56,5	26	0,45
430 310 01	22	270 : 1	200	300	4,7	55	138,5	42,5	15	0,43
430 311 01	17	360 : 1	200	300	3,5	55	152,5	56,5	26	0,45
430 312 01	15	405 : 1	220	300	3,4	55	138,5	42,5	15	0,43
430 313 01	13	480 : 1	220	300	2,9	50	152,5	56,5	26	0,45
430 314 01	11	540 : 1	220	300	2,6	55	152,5	56,5	26	0,45
430 315 01	8,3	720 : 1	220	300	1,9	50	152,5	56,5	26	0,45
430 316 01	7,4	810 : 1	220	300	1,7	55	152,5	56,5	26	0,45
430 317 01	6,3	960 : 1	220	300	1,4	45	152,5	56,5	26	0,45
430 318 01	5,6	1080 : 1	220	300	1,3	45	152,5	56,5	26	0,45
430 319 01	4,9	1215 : 1	220	300	1,1	45	152,5	56,5	26	0,45
430 320 01	4,2	1440 : 1	220	300	0,96	45	152,5	56,5	26	0,45
430 321 01	3,7	1620 : 1	220	300	0,85	45	152,5	56,5	26	0,45
430 322 01	2,8	2160 : 1	220	300	0,64	45	152,5	56,5	26	0,45
430 323 01	2,5	2430 : 1	220	300	0,57	45	152,5	56,5	26	0,45
430 324 01	1,9	3240 : 1	240	300	0,47	45	152,5	56,5	26	0,45
430 325 01	1,6	3645 : 1	240	300	0,41	45	152,5	56,5	26	0,45
430 326 01	1,4	4320 : 1	240	300	0,35	40	152,5	56,5	26	0,45
430 327 01	1,2	4860 : 1	240	300	0,31	40	152,5	56,5	26	0,45
430 328 01	0,9	6480 : 1	240	300	0,23	40	152,5	56,5	26	0,45
430 329 01	0,8	7290 : 1	240	300	0,21	40	152,5	56,5	26	0,45
430 330 01	0,7	8640 : 1	240	300	0,17	40	152,5	56,5	26	0,45
430 331 01	0,6	9720 : 1	240	300	0,16	40	152,5	56,5	26	0,45

To prevent the gearbox from being overloaded, the max. continuous and starting torques stated above must not be exceeded. The effective transmissible torque corresponds to the values at the gearbox shaft.