

Zweifach-Kettenräder mit einseitiger Nabe, ISO 10 B-2

Zweifach-Kettenradscheiben ZRL ohne Nabe, ISO 10 B-2

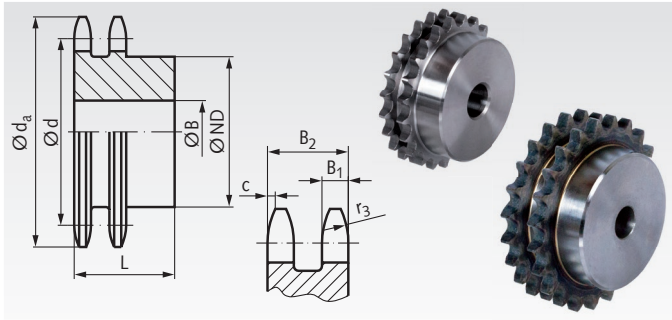

Werkstoff: Stahl C45, wahlweise gehärtet.
Bohrung vorgebohrt.
Mit * versehene Räder aus Grauguss GG25.
Typ ZRS: Nicht gehärtet.
Typ ZRG: Verzahnung induktiv gehärtet (ca. 50 HRC).
Bestellangaben: z.B.: Art.-Nr. 126 108 00, ZRS, ISO 10 B-2, 8 Zähne

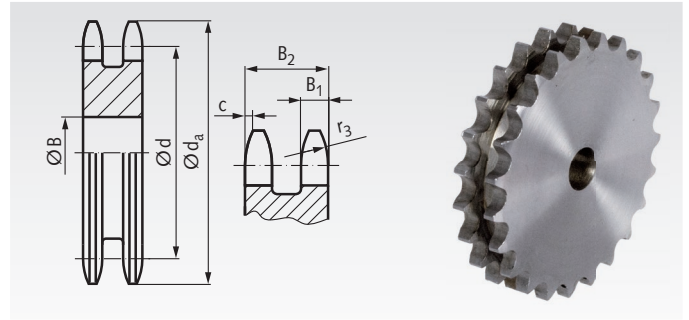

Werkstoff: Kohlenstoffarmer Stahl, nicht härtbar.
Bohrungen vorgebohrt.
Bestellangaben: z.B.: Art.-Nr. 126 211 00, ZRL, ISO 10 B-2, 11 Zähne

ISO 10 B-2, Teilung 5/8 x 3/8"

$B_1 = 9,0 \text{ mm}$, $B_2 = 25,5 \text{ mm}$ $c = 1,6 \text{ mm}$, $r_3 = 16 \text{ mm}$

ISO 10 B-2, Teilung 5/8 x 3/8"

$B_1 = 9,0 \text{ mm}$, $B_2 = 25,5 \text{ mm}$ $c = 1,6 \text{ mm}$, $r_3 = 16 \text{ mm}$

Artikel-Nr. ZRS	Artikel-Nr. ZRG	Zähne- zahl	d_a mm	d mm	ND mm	B mm	L mm	Gewicht kg
126 108 00	126 881 08	8	47,0	41,48	25	12	40	0,19
126 109 00	126 881 09	9	52,6	46,42	30	12	40	0,27
126 110 00	126 881 10	10	57,5	51,37	35	12	40	0,36
126 111 00	126 881 11	11	63,0	56,34	39	14	40	0,45
126 112 00	126 881 12	12	68,0	61,34	44	14	40	0,57
126 113 00	126 881 13	13	73,0	66,32	49	14	40	0,70
126 114 00	126 881 14	14	78,0	71,34	54	14	40	0,84
126 115 00	126 881 15	15	83,0	76,36	59	14	40	0,99
126 116 00	126 881 16	16	88,0	81,37	64	16	45	1,25
126 117 00	126 881 17	17	93,0	86,39	69	16	45	1,47
126 118 00	126 881 18	18	98,3	91,42	74	16	45	1,68
126 119 00	126 881 19	19	103,3	96,45	79	16	45	1,90
126 120 00	126 881 20	20	108,4	101,49	84	16	45	2,14
126 121 00	126 881 21	21	113,4	106,52	85	16	45	2,30
126 122 00	126 881 22	22	118,0	111,55	90	16	45	2,59
126 123 00	126 881 23	23	123,4	116,58	95	16	45	2,87
126 124 00	126 881 24	24	128,3	121,62	100	16	45	3,14
126 125 00	126 881 25	25	134,0	126,66	105	16	45	3,48
126 127 00	126 881 27	27	144,0	136,75	110	20	45	3,94
126 130 00	126 881 30	30	158,8	151,87	120	20	45	4,87
126 132 00	126 881 32	32	168,9	161,95	120	20	45	5,34
126 136 00	126 881 36	36	189,1	182,15	120	20	45	6,38
126 138 00	126 881 38	38	199,2	192,24	120	20	45	6,95
126 145 00*	-	45	235,0	227,58	100	30	50	5,08
126 157 00*	-	57	296,0	288,18	100	30	56	6,81
126 176 00*	-	76	392,1	384,16	100	30	63	8,30
126 183 00*	-	95	488,5	480,14	110	30	63	12,02
126 188 00*	-	114	584,1	576,13	125	30	70	16,50

Artikel-Nr. ZRL	Zähne- zahl	d_a mm	d mm	B mm	Gewicht kg
126 211 00	11	63,0	56,34	12	0,34
126 212 00	12	68,0	61,34	12	0,41
126 213 00	13	73,0	66,32	12	0,51
126 214 00	14	78,0	71,34	12	0,59
126 215 00	15	83,0	76,36	12	0,71
126 216 00	16	88,0	81,37	12	0,80
126 217 00	17	93,0	86,38	12	0,93
126 218 00	18	98,3	91,42	12	1,07
126 219 00	19	103,3	96,45	12	1,15
126 220 00	20	108,4	101,49	12	1,33
126 221 00	21	113,4	106,52	16	1,48
126 222 00	22	118,0	111,55	16	1,60
126 224 00	24	128,3	121,62	16	1,99
126 226 00	26	139,0	131,70	16	2,31
126 227 00	27	144,0	136,75	16	2,55
126 228 00	28	148,7	141,78	16	2,77
126 230 00	30	158,8	151,87	16	3,19
126 235 00	35	184,1	177,10	20	4,40
126 238 00	38	199,2	192,24	20	5,28
126 245 00	45	235,0	227,58	20	7,51
126 248 00	48	250,2	242,73	25	8,54
126 257 00	57	296,0	288,18	25	12,23
126 276 00	76	392,1	384,16	25	22,00
126 283 00	95	488,5	480,14	30	34,50
126 288 00	114	584,1	576,13	30	43,43



Mit * versehene Räder aus Grauguss GG25.

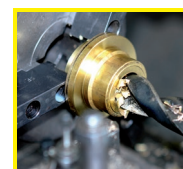

**Fertigbearbeitung im
24-Stunden-Service möglich.
Sonderanfertigungen und
Zeichnungsteile auf Anfrage.**