

Single Pole 4mm^2 ™ Reed Relays

0.5 Amp switching

Stacking on 4mm x 4mm pitch

Products highlighted  are available from Rapid Electronics
www.rapidonline.com

Features

- The industry's smallest through-hole reed relay currently available
- 3 or 5 Volt coils
- 5 Watts, 0.5 Amp switching
- 1 Form A (SPST) Normally Open (NO) Energize to make
- Very fast operate and release times making these relays ideal for high speed test systems
- Plastic package with internal mu-metal magnetic screen
- Ideal for A.T.E. switching matrices or multiplexers
- Highest quality instrumentation grade switches
- Insulation resistance greater than $10^{12} \Omega$
- 100% tested for dynamic contact resistance for guaranteed performance

The Series 124 reed relay range is part of Pickering's new ultra-high density 4mm^2 product line, which take up the minimum board area of only 4mm x 4mm, allowing the highest packing density currently available.

The range features a sputtered ruthenium switch rated at 5 Watts, 0.5 Amps. These are the same reed switches as used in the long established Pickering Series 111, 111P and 117 but are orientated vertically within the package, allowing this high density. If a higher rating is required, please consider our Series 120 which are rated up to 1.0 Amp at 20 Watts but with a higher profile height.

The small size of the package does not allow an internal diode. Back EMF suppression diodes are included in many relay drivers but if they are not, and depending on your drive methods, these may have to be provided externally.

While socketing relays is not normally recommended due to the risk of affecting contact resistance integrity, it is appreciated that sockets may sometimes be desired for ease of servicing/replacement, in the case of a relay being damaged or reaching the end of its working life.

The device has pins on a 2mm square pitch. There are suitable connectors available from some manufacturers, both SMD and Through Hole, that will allow these relays to be stacked in either a row or in a matrix on a 4mm pitch.

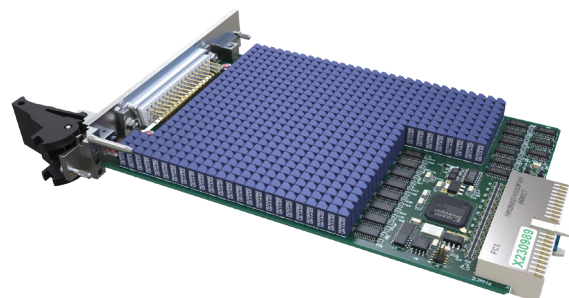
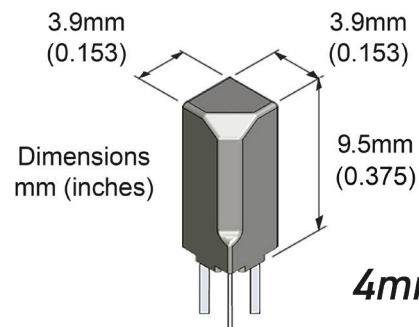
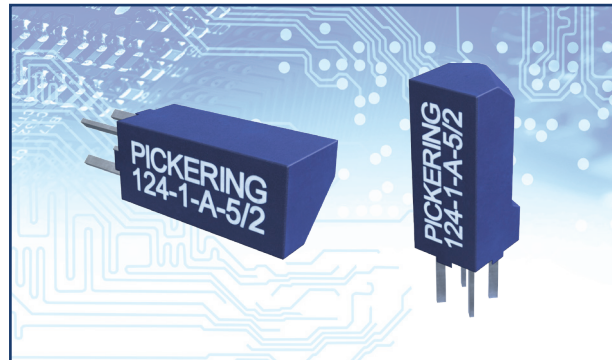

A total of 606 Series 124 relays on an example ultra-high-density PXI module illustrates the packing density of these extremely small Reed Relays.

The reed switch in the Series 124 is suitable for low level or 'cold' switching. In accordance with Pickering convention, this switch is referred to as type number 2. There is no general purpose switch (type number 1) currently available in this series, but the type 2 is suitable for all applications if it is used within its specified ratings. This means that high inrush currents, particularly caused by capacitive loads must be avoided.

Series 124 switch ratings - The contact ratings for each switch type are shown below:

Switch No	Switch form	Power rating	Max. switch current	Max. carry current	Max. switching volts	Life expectancy ops typical (see Note ¹ below)	Operate time inc bounce (max)	Release time	Special features
2	A	5 W	0.5 A	0.5 A	170	10 ⁸	0.2 ms	0.1 ms	All applications

Operating voltages

Coil voltage - nominal	Must operate voltage - maximum at 25°C	Must release voltage - minimum at 25°C
3 V	2.25 V	0.3 V
5 V	3.75 V	0.5 V

Coil data and type numbers

Device type	Type Number	Coil (V)	Coil resistance	Max. contact resistance (initial)	Insulation resistance (minimum)		Capacitance (typical) (see Note ^{2,3} below)	
					Switch to coil @ 1 kV DC	Across switch	Closed switch to coil	Across open switch
1 Form A (energize to make) Switch No. 2	124-1-A-3/2	3	75 Ω	0.18 Ω	10 ¹² Ω	10 ¹² Ω	1.6 pF	0.25 pF
	124-1-A-5/2	5	200 Ω					

Environmental specification

Standard operating temperature range: -20 to +85 °C.

Note: The upper temperature limit can be extended to +125 °C if the coil drive voltage is increased to accommodate the resistance/temperature coefficient of the copper coil winding. This is approximately 0.4% per °C. This means that at 125 °C the coil drive voltage will need to be increased by approximately 40 x 0.4 = 16% to maintain the required magnetic drive level. Please contact sales@pickeringrelay.com for assistance if necessary.

Vibration: Maximum 20 G	Shock: Maximum 50 G
--------------------------------	----------------------------

Note¹ Life expectancy

The life of a reed relay depends upon the switch load and end of life criteria. For example, for an 'end of life' contact resistance specification of 1 Ω, switching low loads (10 V at 10 mA resistive) or when 'cold' switching, typical life is approx 2.5 x 10⁸ ops. At the maximum load (resistive), typical life is 1 x 10⁶ ops. In the event of abusive conditions, e.g. high currents due to capacitive inrushes, this figure reduces considerably. Pickering will be pleased to perform life testing with any particular load condition.

Note² Switch to coil capacitance

Due to the asymmetrical internal construction of the relay, the capacitance to the coil from one switch connection is approximately half the capacitance of the other switch connection, pin 1 is lower. In some applications this feature may be used to advantage for example, in a multiplexer where it is desirable to minimize the capacitance of the common connection to maximize bandwidth.

Note³ Capacitance across open switch

The capacitance across the open switch was measured with other connections guarded.

Pin Configuration and Dimensional Data

Dimensions in Millimeters (Inches in brackets)

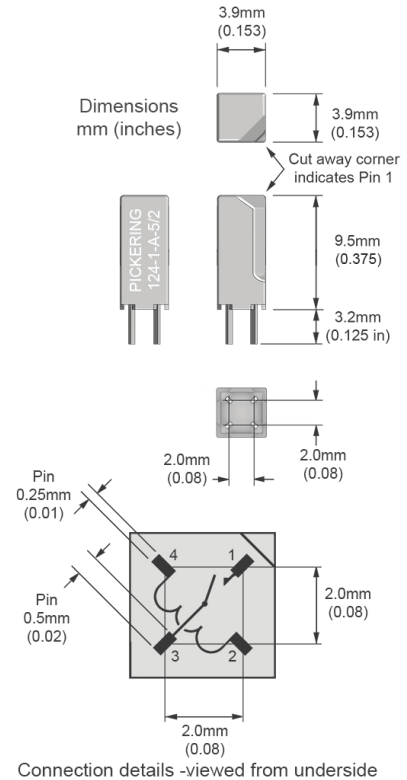

Example of Packing Density - Actual Size

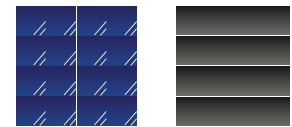

Pickering Electronics' Series 124 Industry standard reed relay

The above full scale graphic illustrates sixteen new Series 124 Relays packed into an area of 1.6cm x 1.6cm, in comparison, only four of the industry standard reed relays can be fitted into the same area.

3D Models: Interactive models of the complete range of Pickering relay products can be downloaded from the web site.

Internal Mu-metal Magnetic Screen

The Series 124 relays are fitted with an internal mu-metal magnetic screen which permits side-by-side stacking on a 4mm pitch.

Order Code

124 - 1 - A - 5 / 2

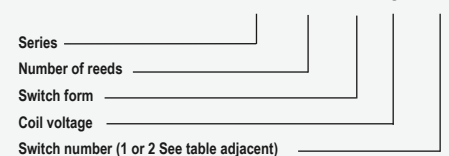

Help

If you need any technical advice or other help, for example, any special tests that you would like carried out, please do not hesitate to contact our Technical Sales Department. We will always be pleased to discuss Pickering relays with you. email: techsales@pickeringrelay.com

Please ask us for a FREE evaluation sample.

Main contact:

UK Headquarters: email: sales@pickeringrelay.com | Tel. +44 1255 428141

Worldwide contacts:

USA: email: ussales@pickeringtest.com | Tel. +1 781 897 1710

Germany: email: desales@pickeringtest.com | Tel. +49 89 125 953 160

China: email: johnson@tomtech.cn | Tel. 0755 8374 5452

For a full list of agents and representatives visit: pickeringrelay.com/agents



ISO9001 Manufacture of Reed Relays FM 29036