

# Red Lion

## *Signal Conditioning and Communications*

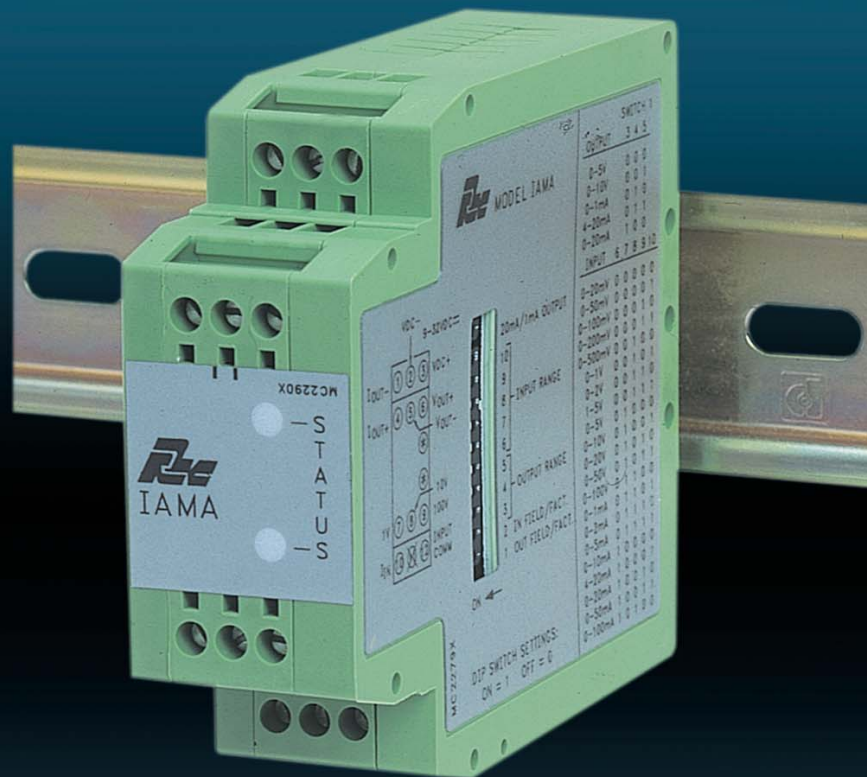













**Signal Conversion**













































**Isolation**

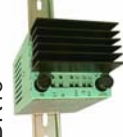







**Power Supplies**





**Communication Modules**

**DIN-Rail Relays**

Models	Page	Functions	Input	Outputs	Package	Power	Agency	Software
IAMA 	167	Signal Conditioner	DC Volts DC Current	DC Volts DC Current	DIN Rail	DC	 	
AAMA 	169	Signal Conditioner	DC Volts DC Current	DC Volts DC Current	DIN Rail	DC		
IAMS 	173	Signal Conditioner	DC Volts DC Current	ALARMS COMMS. RS485	DIN Rail	AC 24 VAC DC		PROGRAMMING SOFTWARE 
VFC/ CFC 	179	Signal Conditioner	DC Volts DC Current	FREQ	Octal Socket	DC		
APMR 	181	3 Phase Fault Detector	AC 230 V 380 V 480 V	ALARMS	DIN Rail	AC		
ITMA 	183	Signal Conditioner	Thermo-couple	DC Volts DC Current	DIN Rail	LOOP DC		
IRMA 	187	Signal Conditioner	RTD	DC Volts DC Current	DIN Rail	LOOP DC		
ITMS 	191	Signal Conditioner	Thermo-couple RTD	ALARMS COMMS. RS485	DIN Rail	AC 24 VAC DC		PROGRAMMING SOFTWARE 

Models	Page	Functions	Input	Outputs	Package	Power	Agency	Software
IFMA 	193	Signal Conditioner		 		 	 	
PRA1 	199	Signal Conditioner		 		 		
IFMR 	195	Speed Switch				 	 	
PRS1 	197	Speed Switch				 		
PSDR6 	207	Power Supply	86 to 132 VAC 184 to 264 VAC	24 VDC @ 650 mA		 	 	
PSDR13 	209	Power Supply	120 VAC	24 VDC @ 1 Amp				
PSDR12 	208	Power Supply	120 VAC 220 VAC	24 VDC @ 100 mA			 (PSDR1200)	

Models	Page	Functions	Input	Outputs	Package	Power	Agency	Software
RLY6 	214	Solid State Relay	4 to 28 VDC	25 A @660 VAC Maximum	DIN Rail		 	
RLY7 	216	3 Phase Solid State Relay	4 to 28 VDC	30 A 3 Phase @ 660 VAC Maximum	DIN Rail		 	
RSRLYB 	211	Relay (Replaceable)	24 VDC	Form C 6 Amp SPDT Contacts	DIN Rail			
AVMR 	218	Relay	24 VDC	Form A 3 Amp SPST Contacts	DIN Rail			

Models	Page	Functions	Input	Outputs	Package	Power	Agency	Software
<p>ICM4</p> 	201	RS232 to RS285 Converter			DIN Rail	DC		
<p>GCM232</p> 	203	RS232 to 20 mA Current Loop Converter			In-line Module	DC		
<p>GCM422</p> 	204	RS422/485 to 20 mA Current Loop Converter			In-line Module	DC		
<p>GWDN</p> 	205	RS422/RS485 DeviceNet Gateway			DIN Rail	Via Bus		



## MODEL IAMA - UNIVERSAL SIGNAL CONDITIONING MODULE

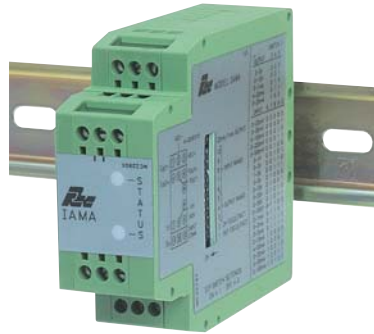

- 3-WAY ISOLATION OF ANALOG SIGNALS
- UNIVERSAL CONVERSION MODULE - INPUTS AND OUTPUTS CAN BE SELECTED VIA DIP SWITCH SETTINGS
- OVER 100 INPUT AND OUTPUT ANALOG CONVERSION COMBINATIONS
- ALL RANGES ARE FACTORY PRECALIBRATED. CUSTOM FIELD CALIBRATION IS AVAILABLE FOR ALL RANGES WHILE MAINTAINING THE FACTORY CALIBRATION FOR FUTURE USE
- 9 to 32 VDC MODULE POWER



UL RECOGNIZED  
USA



UL RECOGNIZED  
CANADA



EMC  
COMPLIANT



ANALOG  
OUTPUT

Click Icon For  
User Bulletin



FAX/WEB  
DOC# 10005

### Product Features

The IAMA3535 Universal Signal Conditioning Module can isolate and convert over 100 combinations of industry standard analog signal ranges. DIP switch range selection eliminates the need to order and stock different modules for each input and output signal range.

In addition to the conversion capabilities, the IAMA module features an optically isolated Input/Output signal circuit and a transformer isolated Power to Input, Power to Output circuit.

The IAMA utilizes a 10 position DIP switch, a 1 position DIP switch and two LED's to accomplish custom input and output calibration and mode selection.

The module's overall full scale accuracy typically exceeds 0.05% depending upon range selection and scaling. The micro processor based design provides ease of field scaling and the onboard E2prom stores scaling values for future recall. The IAMA comes factory precalibrated for all input and output ranges. Factory or custom field scaling can be selected by a simple mode switch change. The IAMA can be factory calibrated in the field if desired.

The module's environmental operating temperature range is -25°C to +75°C. The modular high density packaging and mounting saves time and panel space. The unit is equipped with a universal mounting foot for attachment to standard DIN style rails, including top hat profile rail according to EN50022 - 35x7.5 and 35 x 15 and G profile rail according to EN50035-G32.

### DIMENSIONS "In Inches (mm)"

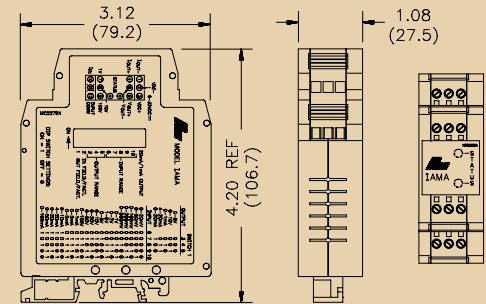

### General Specifications

- POWER:** 9 to 32 VDC, 2.5 W max.
- ISOLATION LEVEL INPUT TO OUTPUT:** 1.5 kV @ 50/60 Hz, 1 min
- ENVIRONMENTAL CONDITIONS:**
  - Operating Temperature Range:** -25 to +75 °C
  - Storage Temperature Range:** -40 to +85 °C
  - Operating and Storage Humidity:** 85% max. relative humidity (non-condensing) from -25 to +75 °C
  - Temperature Coefficient:** ± 0.01%/°C (100 PPM/°C) max.
  - Altitude:** Up to 2000 meters
- CERTIFICATIONS AND COMPLIANCES:**
  - SAFETY**
  - EN 61010-1, IEC 1010-1

UL Recognized Component, File #E179259

Recognized to U.S. and Canadian requirements under the Component Recognition Program of Underwriters Laboratories, Inc.

#### ELECTROMAGNETIC COMPATIBILITY

Immunity to EN 50082-2

Emissions to EN 50081-2

- CONSTRUCTION:** Case body is green high impact plastic
- CONNECTIONS:** 14 AWG max
- MOUNTING:** Standard DIN top hat (T) profile rail according to EN50022 -35 x 7.5 and -35 x 15 and G profile rail according to EN50035-G32.
- WEIGHT:** 4.5 oz. (127.57 g)

### MODEL IAMA - UNIVERSAL SIGNAL CONDITIONING MODULE

#### Input Specifications

- INPUT/OUTPUT RANGES:** See Tables 1 and 2
- ZERO/SPAN ADJUSTMENTS:** Digital (DIP Switch Transition)
- MAX INPUT SIGNAL:**  
**Current Input:** 110 mA DC, 1.1 VDC  
**Voltage Inputs:** Terminal 7- 1 V +10%  
Terminal 8- 10 V +10%  
Terminal 9- 100 V +10%
- INPUT RESISTANCE:**  
**Current:** 10  $\Omega$   
**Voltage:** > 100 K
- INPUT PROTECTION:** Surge suppressor diodes
- ACCURACY (INCLUDING LINEARITY):** Factory:  $\pm 0.1\%$  of span max. for all ranges except 1 mA, 2 mA, and 20 mV. These ranges are accurate to  $\pm 0.2\%$  of span max. All ranges can be field calibrated to 0.1% of span max.
- RESOLUTION:** 0.006% full scale input, 0.006% full scale output

TABLE 1, OUTPUT RANGE SETTINGS

	OUTPUT RANGE	RANGE DIP SWITCHES		
		3	4	5
VOLTAGE OUTPUTS	0 - 5 V	0	0	0
	0 - 10 V	0	0	1
CURRENT OUTPUTS	0 - 1 mA	0	1	0
	4 - 20 mA	0	1	1
	0 - 20 mA	1	0	0

Note: DIP switch settings 0 = OFF 1 = ON

TABLE 2, INPUT RANGE SETTINGS

	RANGE	RANGE DIP SWITCHES				
		6	7	8	9	10
INPUT VOLTAGE	0 - 20 mV	0	0	0	0	0
	0 - 50 mV	0	0	0	0	1
	0 - 100 mV	0	0	0	1	0
	0 - 200 mV	0	0	0	1	1
	0 - 500 mV	0	0	1	0	0
	0 - 1 V	0	0	1	0	1
	0 - 2 V	0	0	1	1	0
	1 - 5 V	0	0	1	1	1
	0 - 5 V	0	1	0	0	0
	0 - 10 V	0	1	0	0	1
	0 - 20 V	0	1	0	1	0
	0 - 50 V	0	1	0	1	1
	0 - 100 V	0	1	1	0	0
INPUT CURRENT	0 - 1 mA	0	1	1	0	1
	0 - 2 mA	0	1	1	1	0
	0 - 5 mA	0	1	1	1	1
	0 - 10 mA	1	0	0	0	0
	4 - 20 mA	1	0	0	0	1
	0 - 20 mA	1	0	0	1	0
	0 - 50 mA	1	0	0	1	1
0 - 100 mA	1	0	1	0	0	

Note: DIP switch settings 0 = OFF 1 = ON

#### Output Specifications

- MAX OUTPUT CURRENT:**  
**Current Output:** 22 mA  
**Voltage Output:** 10 mA
- LOAD RESISTANCE:**  
**Current Output:**  $\leq 600 \Omega$   
**Voltage Output:**  $\geq 1 K\Omega$
- OUTPUT COMPLIANCE:**  
**Current:** 4 to 20 mA, 0 to 20 mA: 12 V min ( $\leq 600 \Omega$ )  
0 to 1 mA: 10 V min ( $\leq 10 K\Omega$ )  
**Voltage:** 10 VDC across a min. 1 K $\Omega$  load (10 mA). Factory calibrated for loads of > 1 M $\Omega$ .
- STEP RESPONSE:** To within 99% of full scale: 300 msec

#### Ordering Information

MODEL NO.	DESCRIPTION	PART NUMBER
IAMA	Universal Signal Conditioning Module	IAMA3535



## MODEL AAMA - UNIVERSAL SIGNAL CONDITIONING MODULE



- 3-WAY ISOLATION OF ANALOG SIGNALS
- UNIVERSAL CONVERSION MODULE - INPUTS AND OUTPUTS CAN BE SELECTED VIA DIP SWITCH SETTINGS
- OVER 100 INPUT AND OUTPUT ANALOG CONVERSION COMBINATIONS
- 18 to 30 VDC MODULE POWER



EMC  
COMPLIANT

Click Icon For  
User Bulletin



FAX/WEB  
DOC# 10019

### Product Features

The AAMA3535 Universal Signal Conditioning Module can isolate and convert over 100 combinations of industry standard analog signal ranges. The universal DIP switch selection feature eliminates the need to order and stock different modules for each input and output signal.

In addition to the conversion capabilities, the AAMA3535 module features an optically isolated Input/Output signal circuit and a transformer (galvanically) isolated Power to Input, Power to Output circuit.

The AAMA3535 module meets the stringent IEC 801 Standard for surge suppression, noise emission and noise immunity. The module is also CE marked for European applications.

The module's overall full scale accuracy can exceed 0.005% depending upon range selection and calibration. A hybrid SMD calibration circuit stores all range and amplification settings. The hybrid circuit maintains a very high accuracy and low drift output signal.

The module's environmental operating temperature range is -20°C to +65°C. The modular high density packaging and mounting saves time and panel space. The modules snap onto standard 35 mm flat DIN rail, and uses removable terminal blocks for easy module wiring.

### DIMENSIONS "In Inches (mm)"

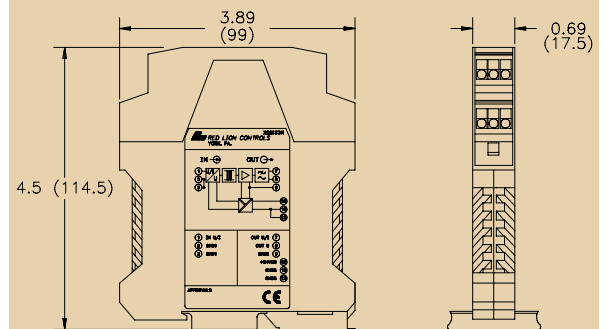

### General Specifications

1. **POWER SUPPLY VOLTAGE:** 18 to 30 VDC @ 60 mA
2. **ISOLATION LEVEL INPUT/OUTPUT:** 1.5 kV @ 50 Hz, 1 minute Opto Isolation
3. **POWER TO INPUT/OUTPUT:** 1.0 kV @ 50 Hz, 1 minute Transformer DC/DC
4. **RESPONSE TIME:** 0.034 sec. max.
5. **OPERATING TEMPERATURE RANGE:** -20 to +65°C (-4 to 145°F)
6. **TEMPERATURE COEFFICIENT:** 100 ppm/K
7. **CONSTRUCTION:** Case body is green, high impact plastic
8. **CONNECTIONS:** 14 AWG wire max.
9. **MOUNTING:** Standard DIN Top hat (T) profile rail according to EN50022 -35 x 7.5 and -35 x 15
10. **WEIGHT:** 3.76 oz (106.59 g)

### MODEL AAMA - UNIVERSAL SIGNAL CONDITIONING MODULE

#### Input Specifications

1. INPUT RANGES:

0 to 60 mV	0 to 100 mV	0 to 200 mV	0 to 300 mV	0 to 500 mV
0 to 1 V	0 to 5 V	0 to 10 V	0 to 20 V	±100 mV
±200 mV	±300 mV	±500 mV	±1 V	±2 V
±5 V	±10 V	±20 V	0 to 5 mA	0 to 20 mA
4 to 20 mA	1 to 5 V	0 to 2 V	±60 mV	

2. ZERO/SPAN ADJUSTMENTS: Range Dependent

3. MAX. INPUT SIGNAL:

Current Input: 50 mA

Voltage Input: 30 V

4. INPUT RESISTANCE:

Current: 50 Ω

Voltage: 1 MΩ

5. INPUT PROTECTION: Surge suppressor diodes

6. MAX. INPUT FREQUENCY: 30 Hz

7. OVERALL FULL SCALE ACCURACY: 0.1% to 0.05%

Dependent on Calibration Source

#### Output Specifications

1. OUTPUT RANGES:

0 to 5 V	±5 V	0 to 10 V	±10 V
0 to 20 mA	4 to 20 mA	1 to 5 V	

2. MAX. OUTPUT SIGNAL:

Current Output: 30 mA

Voltage Output: 15 V

3. LOAD RESISTANCE:

Current Output: ≤ 500 Ω max.

Voltage Output: ≥ 5 KΩ

#### Ordering Information

MODEL	DESCRIPTION	PART NUMBER
AAMA	Universal Signal Conditioning	AAMA3535

## MODEL AIMI - 0 (4) - 20 MA PASSIVE LOOP POWERED ISOLATOR



- PROVIDES INPUT/OUTPUT ISOLATION
- LOOP POWERED



UL RECOGNIZED  
USA



EMC  
COMPLIANT

Click Icon For  
User Bulletin



FAX/WEB  
DOC# 10015

### Product Features

Compact passive loop powered isolator provides ground potential isolation of analog control circuits, 0 to 20 mA and 4 to 20 mA. The isolator ensures safe decoupling of the sensor signal from the control electronics.

The Model AIMI is powered by the input loop current. The input loop current is converted to an alternating current signal using a chopper circuit, isolated by a transformer, rectified, and filtered at the output loop.

If the output loop resistance is less than 170 Ω, the input voltage drop is 6.5 V. If the output loop resistance is between 170 Ω and 1000 Ω, the input voltage drop increases linearly from 6.5 to 23.1 V at a loop current of 20 mA.

The output signal is a current source, for a load connected between the (+) and (-) terminals.

### DIMENSIONS "In Inches (mm)"

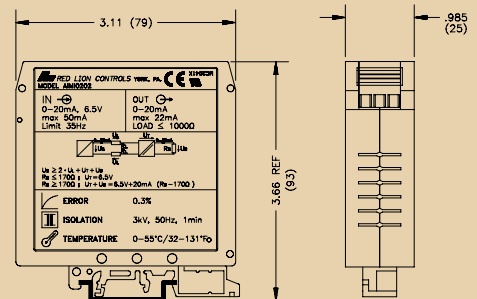

### General Specifications

1. **ISOLATION VOLTAGE:** 3 KV, 50 Hz, for 1 minute
2. **OPERATING TEMPERATURE RANGE:** 0 to 55°C
3. **CONSTRUCTION:** Case body is green, high impact plastic.
4. **MOUNTING:** Standard DIN style rail, including top hat (T)

5. **WEIGHT:** 2.976 oz (84.37 g)

### Input Specifications

1. **INPUT RANGE:** 0(4) to 20 mA
2. **MAXIMUM INPUT CURRENT/VOLTAGE:** 50 mA/25 VDC
3. **MINIMUM INPUT CURRENT/VOLTAGE:** 0 mA/6.5 V
4. **INPUT RESISTANCE @ 20mA:** 325-1155 Ω (dependent on load)
5. **VOLTAGE DROP AT INPUT:** (See Chart at Right)
6. **MAXIMUM INPUT FREQUENCY:** 35 Hz
7. **RESPONSE TIME:** 0.029 sec. max.

#### Voltage Drop at Input

Voltage drop across the input is calculated by determining the load resistance of the output loop, drawing a vertical line to the curve, then horizontally to the voltage drop.

A load resistance of less than 170 Ω results in a 6.5 V drop. For loads from 170 to 1000 Ω, the formula is:

$$V_{drop} = 6.5 + [0.02 \times (R_{load} - 170)]$$

As an example, 400 Ω load resistance results in a voltage drop of 11.1 V on the input.

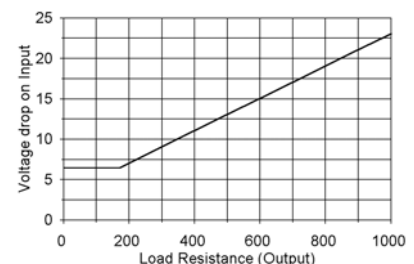

### MODEL AIMI - 0 (4) - 20 MA PASSIVE LOOP POWERED ISOLATOR

#### Output Specifications

1. **OUTPUT SIGNAL:** 0 to 20 mA  
**Load Resistance:**  $\leq 1000 \Omega$

#### Ordering Information

MODEL NO.	INPUT	OUTPUT	PART NUMBER
AIMI	0 (4)-20 mA	0 (4)-20 mA	AIMI0202

## MODEL IAMS - SMART ANALOG TO MODBUS CONDITIONER W/ALARMS



- ANALOG TO MODBUS CONVERSION
- 18 DIFFERENT DC ANALOG INPUT RANGES
- PROCESSOR BASED SCALING
- PC CONFIGURATION SOFTWARE
- DUAL SETPOINT RELAY ALARMS
- FOUR WAY SIGNAL ISOLATION



Click Icon For User Bulletin



FAX/WEB  
DOC # 10016

### Product Features

The IAMS3535 Smart Analog to MODBUS Conditioner with Alarms module accepts a wide range of DC analog process signals. There are eighteen different DC analog input ranges which determine the input span and type. The input accepts a maximum of 110 VDC and 110 mA DC.

The IAMS converts an analog input signal into a register format that can be read using MODBUS ASCII or RTU protocol. With the features of gain and offset, the input signal can be scaled to meet process requirements. Additionally, two setpoint values can be entered for dual relay process monitoring alarms.

The IAMS is programmed with Windows® based SFIMS software. The software allows configuration, calibration, and storage of IAMS program files. Additionally, all setup parameters can be interrogated and modified through MODBUS register and coil commands.

The RS485 port allows the IAMS to be multidropped, with Baud rates up to 38400. The CBPRO007 programming cable converts the RS232 port of a PC to RS485, and is terminated with an RJ-11 connector. The bidirectional capability of the CBPRO007 allows it to be used as a permanent interface cable as well as a programming cable.

The IAMS's two Form A relay alarms can be configured independently for absolute high or low acting with balanced or unbalanced hysteresis. Alarm 2 can also be configured for deviation and band alarms. In these modes, Setpoint 2 tracks Setpoint 1. Adjustable alarm trip delays can be used for delaying

output response. The alarms can be programmed for Latching and Standby. Latched alarms must be reset via serial command. Standby eliminates power-up tripping for low acting alarms. The output relays can also be manually controlled via register commands.

The module's high density packaging and DIN rail mounting saves time and panel space. The module is equipped with a universal mounting foot for attachment to standard DIN style rails, including top hat profile according to EN50022 -35 x 7.5 and -35 x 15, and G profile rail according to EN5035-G32.

### DIMENSIONS "In Inches (mm)"

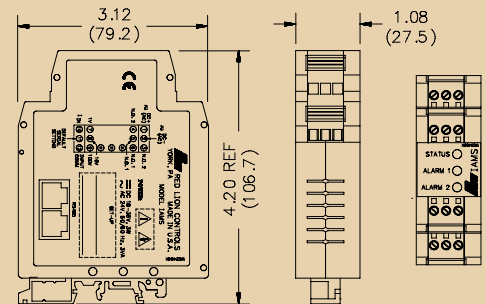

### General Specifications

- POWER:** 18-36 VDC, 3.0 W max. or 24 VAC, 4 VA max.
- ISOLATION LEVEL:** 1.5 kV @ 50/60 Hz, 1 min. between input, RS485 and power supply. 2300 Vrms, 1 min. for relay contacts.
- MEMORY:** Nonvolatile E<sup>2</sup>PROM retains all programmable parameters.
- ENVIRONMENTAL CONDITIONS:**
  - Operating Temperature Range:** -20 to +65 °C
  - Storage Temperature Range:** -40 to +85 °C
  - Operating and Storage Humidity:** 85% max. relative humidity (non-condensing) from -20 to +65 °C
  - Temperature Coefficient:** +0.01%/ °C (100 PPM °C) max.
  - Altitude:** Up to 2000 meters

### MODEL IAMS - SMART ANALOG TO MODBUS CONDITIONER W/ALARMS

#### General Specifications Continued

##### 5. CERTIFICATIONS AND COMPLIANCE:

###### SAFETY

EN 61010-1, IEC 1010-1

###### ELECTROMAGNETIC COMPATIBILITY

Immunity to EN 50082-2

Emissions to EN 50081-2

6. **CONSTRUCTION:** Case body is green high impact plastic. Installation Category II, Pollution Degree 2.

7. **CONNECTIONS:** 14 AWG max.

8. **MOUNTING:** Universal mounting foot for attachment to standard DIN style mounting rails, including top hat (T) profile rail according to EN50022 - 35 x 7.5 and -35 x 15, and G profile rail according to EN50035 - G32.

9. **WEIGHT:** 4.5 oz. (127.57 g)

#### Input Specifications

##### 1. INPUT DC RANGES:

0-20 mV, 0-50 mV, 0-100 mV, 0-200 mV, 0-500 mV, 0-1V, 0-2 V, 0-5 V, 0-10 V, 0-20 V, 0-50 V, 0-100 V, 0-2 mA, 0-5 mA, 0-10 mA, 0-20 mA, 0-50 mA, 0-100 mA

##### 2. MAX. INPUT SIGNAL:

**Current Input:** 110 mA DC

**Voltage Inputs:** Terminal 7: 1 VDC +10%  
Terminal 8: 10 VDC +10%  
Terminal 9: 100 VDC +10%

##### 3. INPUT RESISTANCE:

**Current:** 10 Ohms

**Voltage:** greater than 100 K

##### 4. INPUT PROTECTION:

Surge suppressor diode

**Current Terminal:** Protected to 110 mA DC max., 1.1 VDC.

**100 V Terminal:** Protected to 110 VDC.

**1 V & 10 V Terminal:** Protected to 100 VDC for one minute.

##### 5. INPUT COMMON MODE REJECTION:

50/60 Hz, 110 dB min.

##### 6. A/D CONVERTER:

16 bit resolution

##### 7. STEP RESPONSE:

150 msec. max.

##### 8. ACCURACY (including linearity):

0.1% of span

##### 9. RESOLUTION:

0.002% of span

##### 10. GAIN / OFFSET:

Programmable

#### Output Specifications

##### 1. SERIAL COMMUNICATIONS:

**Type:** RS485, MODBUS RTU and ASCII modes

**Baud:** 300, 600, 1200, 2400, 4800, 9600, 19.2K, and 38.4K

**Format:** 7/8 bit, odd, even and no parity

**Transmit Delay:** Programmable. (See Transmit Delay explanation in Step 6)

**Transmit Enable (TXEN):** (primarily for 20 mA loop converter)

$V_{OH} = 10$  VDC max.  $V_{OL} = 0.5$  VDC @ 5 mA max. current limit

##### 2. RELAY OUTPUTS:

**Type:** 2 Form A N.O. contacts

**Rating:** 5A @ 30 VDC or 250 VAC max. (resistive)

1/10 HP @ 120 VAC (inductive)

**Response Time:** 5 msec. to close after step response, 3 msec. to open.

##### 3. OUTPUT ON DELAY TIME:

Programmable from 0 to 3200 sec,  $\pm 0.01\%$  - 1 sec. max.

#### Ordering Information

MODEL NO.	DESCRIPTION	PART NUMBER
IAMS	Smart Analog to Modbus Conditioner w/Alarms	IAMS3535
SFIMS	PC Configuration Software for Windows	SFIMS
CBPRO	Programming Interface Cable	CBPRO007
CBJ	Cable RJ11 to Unterminated 7 foot length	CBJ11A07
	RJ Connector to Terminal Adapter	DRRJ11T6

## MODEL AIMR - LOOP POWERED SETPOINT ALARM



- LOOP POWERED - NO EXTERNAL 24 VDC POWER SUPPLY REQUIRED
- LOW BURDEN ON THE 4 TO 20 mA LOOP (275Ω)
- BI-STABLE RELAY - REQUIRES NO HOLDING CURRENT
- CONFIGURABLE RELAY ACTION - LATCHING OR NON-LATCHING
- SPDT RELAY CONTACT RATED 1 A, 125 VAC
- REPEATABILITY BETTER THAN 0.3%



Click Icon For User Bulletin



FAX/WEB  
DOC# 10002

### Product Features

The Setpoint Module is a primary or redundant industrial process control alarm. The setpoint module features a loop powered threshold monitoring circuit with a bi-stable relay, LED indication of relay status, configurable hysteresis function and relay action. The threshold is set using a 20-turn potentiometer, while the configurable functions are set by moveable jumper settings.

The loop connections are made on the input side of the module through pluggable terminal blocks, terminals #1 and #2, featuring proven gas tight wire clamping technology. Inputs and outputs are physically separated to opposite sides of the module to ensure correct connection of the inputs and outputs. Relay connections are also made through pluggable terminal blocks.

Hysteresis may be set to 0.1 mA or 1.0 mA, depending upon the application. A 0.1 mA setting allows higher precision response for slowly varying signals, while the 1.0 mA setting is useful for applications where the signal has significant overshoot and undershoot (such as tank levels with unstable liquids).

Relay function may be set in one of two modes: latching or non-latching. Latching mode engages the relay when the input signal crosses the setpoint threshold, and prevents the relay from releasing, when the signal drops below the setpoint threshold. A "RESET" button on the top of the module is used to release the relay when the input signal is below the setpoint. Non-latching mode allows the relay to release when the signal drops below the setpoint threshold.

A combination of through hole and surface mount technology provides stable, low drift performance, even in harsh industrial environments. Rhodium-plated contacts ensure low contact resistance even when low-level signals are switched, while levels up to 1 A and 125 VAC are also accommodated.

The module's environmental operating temperature range is -20°C to +65°C. The modular high density packaging and mounting saves time and panel space. The modules snap onto standard 35 mm flat DIN rail.

### DIMENSIONS "In Inches (mm)"

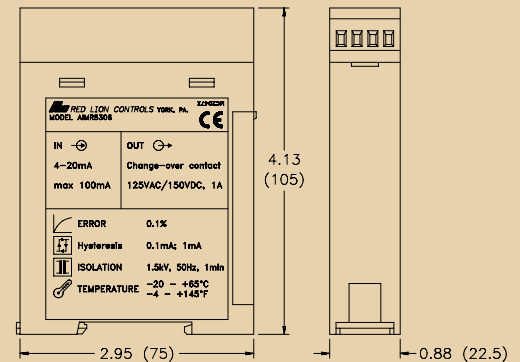

### General Specifications

- OPERATING TEMPERATURE RANGE:** -20 to +65°C (-4 to 149°F)
- CONSTRUCTION:** Case body is green, high impact plastic.
- CONNECTIONS:** 24 -14 AWG wire
- MOUNTING:** Standard DIN Top hat (T) profile rail according to EN50022 - 35 x 7.5 and 35 x 15.
- WEIGHT:** 3.25 oz (92.08 g)

### MODEL AIMR - LOOP POWERED SETPOINT ALARM

#### Input Specifications

1. **INPUT SIGNAL:** 4 to 20 mA
2. **VOLTAGE DROP:** 5.5 V
3. **LOOP BURDEN:** 275  $\Omega$
4. **SETPOINT RANGE:** 4 to 20 mA
5. **HYSTERESIS RANGE:** 0.1 mA, 1.0 mA
6. **TEMPERATURE COEFFICIENT:** <0.01%/K

#### Output Specifications

1. **OUTPUT TYPE:** Form C contacts max. rating 1 A @ 125 VAC, 150 VDC  
**Max. Switching Capacity:**  
30 W DC  
60 VA AC  
**Mechanical Life:** 108 switching cycles

#### Ordering Information

MODEL NO.	DESCRIPTION	PART NUMBER
AIMR	Loop Powered Setpoint Switch	AIMR5306



## MODEL AAMR - DUAL SETPOINT ANALOG ALARM MODULE



- SELECTABLE ANALOG INPUTS ( 0 to 10 VDC or 0 to 20 mA)
- 0 to 100% FULL SCALE RELAY TRIP POINT ADJUSTMENTS
- 20 to 30 VDC MODULE POWER  $\pm 2\%$  ZERO/SPAN
- FORM C RELAY OUTPUTS RATED 3 A, 250 VAC/DC
- REPEATABILITY BETTER THAN 0.1% FULL SCALE
- ACCURACY GREATER THAN 0.5% FULL SCALE



UL RECOGNIZED  
USA

EMC  
COMPLIANT

ALARMS

Click Icon For  
User Bulletin



FAX/WEB  
DOC# 10001

### Product Features

The Dual Setpoint Module is specifically designed to address the rigorous demands of process control applications. The flexibility of either internal or external alarm setpoint adjustments and DIN rail mounting, creates many installation possibilities.

The setpoint module accepts either 0(4) to 20 mA or 0 to 10 VDC analog input signals. The input signal level is selected by a series of DIP switches found behind the module's side door. DIP switch selectable variables include a 1% setpoint hysteresis and normally open/normally closed selectable alarm relay action.

The two digit, thumbwheel switches located on the top of the module allow for easy adjustment of the alarm setpoints. A corresponding yellow LED indicates the status of the relay contact for each setpoint.

Each setpoint has a 0 to 4 second on-delay timer adjustment. This on-delay adjustment is very useful in applications involving turbulence. The time delay will eliminate relay chatter caused by any analog level process signal's quick fluctuation.

The setpoint module contains a  $\pm 2\%$  zero and span adjustment for fine calibration of the setpoint trip points. The zero and span adjustments are found in the same area as the DIP switch adjustments.

The module's environmental operating temperature range is -20°C to +65°C. The modular high density packaging and mounting saves time and panel space. The modules snap onto standard 35 mm flat DIN rail.

### DIMENSIONS "In Inches (mm)"

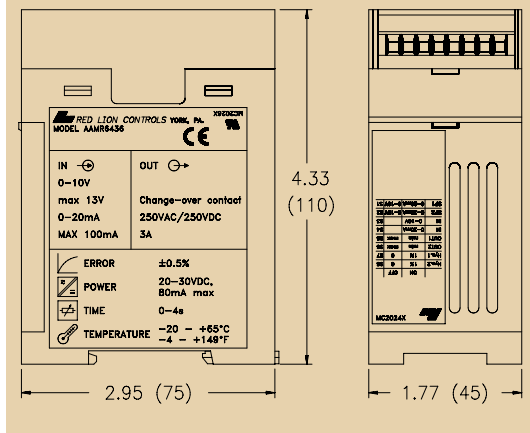

### General Specifications

1. **POWER SUPPLY VOLTAGE:** 20 to 30 VDC @ 80 mA
2. **OPERATING TEMPERATURE RANGE:** -20 to +65°C (-4 to 149°F)
3. **CONSTRUCTION:** Case body is green, high impact plastic
4. **CONNECTIONS:** 14 AWG wire max.
5. **MOUNTING:** Standard DIN top hat (T) profile rail according to EN50022-35 x 7.5 and 35 x 15.
6. **WEIGHT:** 7.46 oz (211.37 g)

### Input Specifications

1. **INPUT SIGNALS:** 0 to 10 VDC, 0 (4) to 20 mA - DIP switches 1 to 4  
**Max. Allowable Input Signal Level:** 13 VDC, 100 mA
2. **RESPONSE TIME:** 15 msec max.
3. **INPUT RESISTANCE:**  
**Current:**  $\leq 100 \Omega$   
**Voltage:**  $\geq 100 K\Omega$
4. **INPUT PROTECTION:** Surge suppressor diodes
5. **SETPOINT RANGE:** 0 to 10 VDC or 0 (4) to 20 mA  
**Range:** 0 to 99% of Input Range  
**Hysteresis:** 1% - DIP switches 7 & 8
6. **ZERO/SPAN CALIBRATION ADJUSTMENTS:**  $\pm 2\%$  0.1 mA, 1.0 mA
7. **ACCURACY:**  $\leq 0.5\%$  full scale
8. **REPEATABILITY:**  $\leq 0.1\%$  full scale

### MODEL AAMR - DUAL SETPOINT ANALOG ALARM MODULE

#### Output Specifications

- OUTPUT TYPE:** 2 Form C contacts max. rating 3 A @ 250 VAC/DC  
**Contacts:** Silver Cadmium Oxide (Ag CdO)  
**Relay Output Time Delay:** 0 to 4 seconds

#### Ordering Information

MODEL NO.	DESCRIPTION	PART NUMBER
AAMR	Dual Setpoint Analog Alarm	AAMR6436

# Signal Conditioning & Communications

## DC Inputs

### MODEL VFC - VOLTAGE TO FREQUENCY CONVERTER MODEL CFC - CURRENT TO FREQUENCY CONVERTER



- 0 to 10 VDC OR 4 to 20 mA INPUT UNITS
- AC OR DC OPERATION
- ADJUSTABLE ZERO & SPAN FOR FREQUENCY FINE TUNE
- ADJUSTABLE LOW END CUT-OUT (Output Inhibit)
- 3 NPN OPEN COLLECTOR OUTPUTS (10 KHz, 1 KHz, 100 Hz)
- LINEARITY 1% OF FULL SCALE

Click Icon For  
User Bulletin



FAX/WEB  
DOC # 12015

## Product Features

The Voltage/Current to Frequency Converter is a plug-in module which converts either 0 to 10 VDC or 4 to 20 mA analog input signals (*specify when ordering*) to a frequency output. In typical applications, a process is monitored by a transducer providing an analog output which is converted to a frequency by the module and then totalized by an electronic counter. The Models VFC and CFC provide this conversion process with linearity to within 1% of full scale output. Zero and Span potentiometers are accessible at the top of the module and provide fine tuning of the frequency outputs. A low end Output Inhibit adjustment is accessible at the top of the module to disable the output frequencies up to 10% of full scale, which prevents totalizing false counts during process start-up or other abnormal conditions. Three full scale frequencies are simultaneously available; 10 KHz, 1 KHz, and 100 Hz. These frequency outputs are NPN Open Collector transistors and easily interface to most counters and totalizers. The modules may be operated from either 115 or 230 VAC (*specify when ordering*) or from DC supplies from +9 to +16 VDC.

The VFC or CFC Models are packaged in a convenient 8-pin octal plug-in case that mates with a UL and CSA rated base mounted or DIN rail mounted socket. The socket (*ordered separately*) features clamp type screw terminals which accept stripped wires without lugs.

## DIMENSIONS "In Inches (mm)"

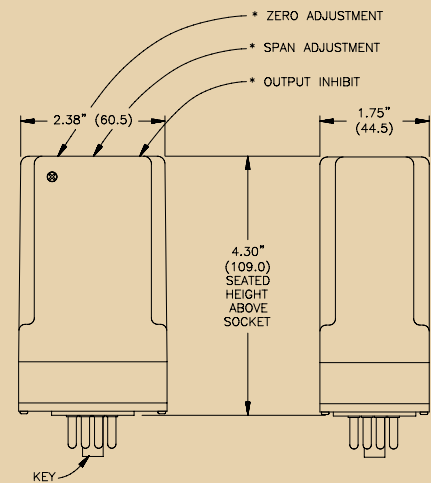

## General Specifications

1. **POWER:**
  - AC: 115 or 230 VAC  $\pm 10\%$ , 50/60 Hz, 2.0 VA (See Ordering Information).
  - DC: +9 to +16 VDC @ 45 mA max.
2. **OPERATING TEMPERATURE:** 0°C to +60°C
3. **STORAGE TEMPERATURE:** -40°C to +80°C
4. **WEIGHT:** Module - 8.0 oz. (227 g)

### MODEL VFC - VOLTAGE TO FREQUENCY CONVERTER MODEL CFC - CURRENT TO FREQUENCY CONVERTER

#### Input Specifications

##### 1. INPUT:

**Model VFC:** 0 to 10 VDC, Impedance greater than 600 K $\Omega$ .  
**Model CFC:** 4 to 20 mA, 30  $\Omega$  Impedance, burden less than 600 mV @ 20 mA  
**Protection:** 100% of full scale input  
**Common Mode Rejection:** 120 dB, 0-60 Hz  
**Normal Mode Rejection:** 35 dB @ 50/60 Hz

##### 2. ACCURACY:

**Linearity:** within 1% of full scale  
**Zero Drift:** 0.06% per °C of full scale  
**Span Drift:** 0.04% per °C of output frequency  
Linearity over power input of +9 to +16 VDC = within 2% of full scale.

#### Output Specifications

1. **OUTPUTS:** All outputs NPN Open Collector transistor,  $I_{SNK} = 10$  mA max.,  $V_{OH} = 30$  VDC max.,  $V_{SAT} = 1$  V @ 10 mA.  
**Terminal 3:** 0-10 KHz, 50/50 duty cycle  
**Terminal 4:** 0-1 KHz, 80% high/20% low duty cycle  
**Terminal 5:** 0-100 Hz, 80% high/20% low duty cycle

#### Ordering Information

MODEL NO.	DESCRIPTION	PART NUMBER
VFC	Voltage to Frequency Converter, 115 VAC	VFC10000
	Voltage to Frequency Converter, 230 VAC	VFC20000
CFC	Current to Frequency Converter, 115 VAC	CFC10000
	Current to Frequency Converter, 230 VAC	CFC20000
—	Base Mount, 8-Pin Octal Socket	SKT10000
—	Din Rail Mount, 8-pin Octal Socket	SKTDIN00

## MODEL APMR - 3 PHASE FAULT DETECTION DIN RAIL MODULE

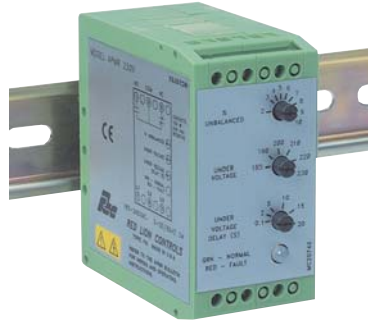

- PROTECTS AGAINST PHASE LOSS, UNBALANCE, UNDER VOLTAGE, AND PHASE REVERSAL
- AVAILABLE IN 230, 380, OR 480 VAC
- LOW COST
- DIN RAIL MOUNTABLE
- INRUSH UNDER VOLTAGE DELAY



Click Icon For User Bulletin



FAX/WEB  
DOC# 10003

### Product Features

The APMR protects three phase equipment, mostly motors, from destructive line conditions. Specifically it detects Phase Reversal, Phase Loss, Phase Unbalance and Low Voltage. All of these conditions, except for Phase Reversal, produce excessive heating of motor windings, causing immediate or cumulative damage to the motor. Phase Reversal will cause a motor to operate in the reverse intended direction, possibly damaging machinery.

There are three models available; 230 VAC, 380 VAC, and 480 VAC. The 230 VAC model is used with 208, 220, 230, and 240 VAC rated equipment. The 380 VAC model is used with 380 and 415 VAC (European) equipment. The 480 VAC model is used with 440, 460, and 480 VAC rated equipment. The electrical

connection is three wire Delta or WYE configurations (no neutral connection required).

The output is SPDT relay and LED. The relay is typically connected in series with a motor contactor coil to inhibit motor start or to disconnect the motor in the presence of a fault condition. The relay automatically resets when the fault clears. The relay is typically used in a latching configuration so the motor has to be restarted after the fault is cleared. The LED illuminates green when all conditions are normal - no fault. When the LED is green, the relay is energized. When a fault occurs, the LED turns red and the relay is de-energized. If phase loss occurs on L1 or L3 the LED turns-off and the relay is de-energized.

### DIMENSIONS "In inches (mm)"

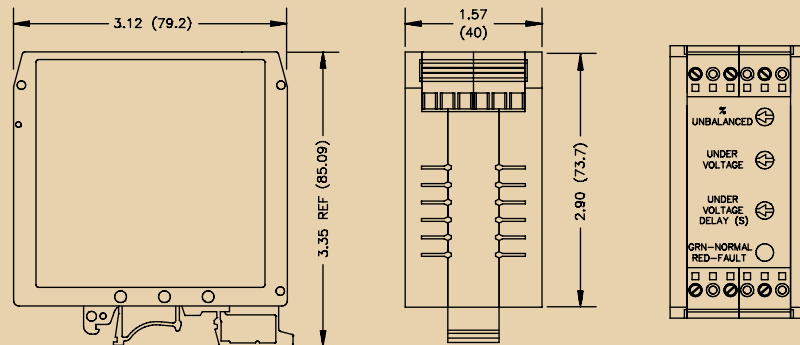

### General Specifications

- ENVIRONMENTAL CONDITIONS:**  
**Operating Temperature:** 0 to 55°C  
**Storage Temperature:** -40 to 80°C  
**Operating and Storage Humidity:** 85% max. relative humidity (non-condensing) from 0°C to 50°C.  
**Altitude:** Up to 2000 meters
- ISOLATION BREAKDOWN RATING:** 3000 V
- CERTIFICATIONS AND COMPLIANCES:**  
**SAFETY**  
 EN 61010-1, IEC 1010-1

#### ELECTROMAGNETIC COMPATIBILITY

Immunity to EN 50082-2  
 Emissions to EN 50081-2

- MOUNTING:** Universal mounting foot for attachment to standard DIN style mounting rails, including top hat (T) profile rail according to EN50022 -35 X 7.5 and -35 X 15, and G profile rail according to EN50035 - G32.
- CONNECTION:** Compression type terminal block
- CONSTRUCTION:** High impact green plastic case
- WEIGHT:** 7.0 oz. (0.20 Kg)

### MODEL APMR - 3 PHASE FAULT DETECTION DIN RAIL MODULE

#### Input Specifications

- POWER:**
  - 230 VAC:** Min = 185, Max = 264, 3 VA (Typical)⇒Nominal is 185 to 240, 48 to 62 Hz.
  - 380 VAC:** Min = 320, Max = 457, 3 VA (Typical)⇒Nominal is 320 to 415, 48 to 62 Hz.
  - 480 VAC:** Min = 380, Max = 528, 3 VA (Typical)⇒Nominal is 380 to 480, 48 to 62 Hz.
- TEMPERATURE COEFFICIENTS:**
  - Unbalance:** ±0.5% Over temperature range
  - Undervoltage:** ±200 PPM/°C

#### Output Specifications

- OUTPUT:** SPDT 10 A @ 240 VAC (resistive load); 1/2 HP @ 240 VAC
  - Response Time:**
    - Phase Reversal:** Not greater than 120 msec
    - Low Voltage:** 0.1 to 20 sec, user adjustable
    - Phase Loss and Unbalance:** Not greater than 100 msec

#### Ordering Information

MODEL NO.	DESCRIPTION	PART NUMBERS FOR AVAILABLE SUPPLY VOLTAGES		
		480 VAC	380 VAC	230 VAC
APMR	3 Phase Fault Detection Module	APMR0096	APMR0086	APMR0016

## MODEL ITMA - INTELLIGENT THERMOCOUPLE MODULE WITH ANALOG OUTPUT



- USER PROGRAMMABLE INPUT (Thermocouple types J, K, T, & E, or millivolt)
- 12 to 42 VDC LOOP POWERED (4 to 20 mA Output)
- MICROPROCESSOR CONTROLLED
- SIMPLE ADJUSTABLE RANGE SETTING (Using Input Signal)
- THERMOCOUPLE BREAK DETECTION
- MOUNTS ON "T" AND "G" STYLE DIN RAILS
- 2-WAY ELECTRICAL ISOLATION (INPUT/OUTPUT & POWER)
- HIGH-DENSITY PACKAGING (22.5 mm wide)
- WIDE OPERATING TEMPERATURE RANGE



EMC COMPLIANT



ANALOG OUTPUT

Click Icon For User Bulletin



FAX/WEB  
DOC # 10010

### Product Features

The ITMA accepts a thermocouple or millivolt input and converts it into a 4 to 20 mA current output. The 4 to 20 mA output is linearly proportional to the temperature or the millivolt input. This output is ideal for interfacing to indicators, chart recorders, controllers, or other instrumentation equipment.

The ITMA is loop-powered which means that the same two wires are carrying both the power and the output signal. The unit controls the output current draw from 4 to 20 mA in direct proportion to the input change while consuming less than 4 mA for power. The conversion to a current output signal makes the ITMA less susceptible to noise interference and allows accurate transmission over long distances. The 2-Way isolation allows the use of grounded thermocouples which can provide additional noise reduction benefits.

The ITMA uses a ten position DIP switch to accomplish the input sensor configuration, range selection, and unit calibration. A simple range setting technique (Field Calibration) is used so the actual input signal adjusts the output current for scaling. This technique eliminates the need for potentiometers which are vulnerable to changes due to vibration.

The unit is equipped with a universal mounting foot for attachment to standard DIN style mounting rails, including top hat rail (T) according to EN 50 022 - 35 x 7.5 and 35 x 15, and G profile according to EN 50 035 - G 32.

### DIMENSIONS "In Inches (mm)"

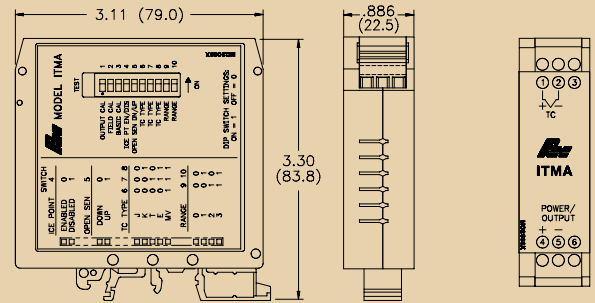

### General Specifications

- POWER:** 12 to 42 VDC \*(Loop powered). The power supply must have a 30 mA min. capacity.  
[\* Min. voltage must be increased to include the drop across any current display indicator]
- ENVIRONMENTAL CONDITIONS:**  
**Operating Temperature Range:** -25°C to 75°C (-13°F to 167°F)  
**Storage Temperature Range:** -40°C to 85°C (-40°F to 185°F)  
**Operating and Storage Humidity:** 85% max. relative humidity (non-condensing) from -25°C to 75°C.  
**Temperature Coefficient:** ± 0.01% of input range per °C  
**Ice Point Compensation:** ± 0.75°C for a 50°C change in temperature  
**Altitude:** Up to 2000 meters.
- DIELECTRIC WITHSTAND VOLTAGE:** 1500 VAC for 1 minute, at 50 VAC working volts, from Input to Output
- CERTIFICATIONS AND COMPLIANCES:**  
**SAFETY**  
 EN 61010-1, IEC 1010-1  
**Electromagnetic Compatibility**  
 Immunity to EN 50082-2  
 Emissions to EN 50081-2
- MOUNTING:** Universal mounting foot for attachment to standard DIN style mounting rails, including top hat (T) profile rail according to EN50022 - 35 x 7.5 and 35 x 15, and G profile rail according to EN50035 - G32.
- CONNECTION:** Compression type terminal block
- CONSTRUCTION:** High impact green plastic case
- WEIGHT:** 2.7 oz (76.54 g)

## MODEL ITMA - INTELLIGENT THERMOCOUPLE MODULE WITH ANALOG OUTPUT

### Input Specifications

- INPUT:** J, K, T, E, mV [selectable via DIP switch]
- RANGE & ACCURACY:** (12 Bit resolution)  
**Accuracy:**  $\pm (0.075\% \text{ Range} + 0.25^\circ\text{C [Conformity]} + 0.50^\circ\text{C [Ice Point]})$  at 23°C after 20 min. warm-up, conforming to ITS-90.  
*Note: TC Conformity and Ice Point do not apply to mV input*  
**Relative Humidity:** Less than 85% RH (non-condensing)  
**Span:** The input span can be set to a min. of 1/8 of the full scale range, anywhere within that range.

**Thermocouple Accuracy for each type and the corresponding ranges:**

TC (INPUT)	RANGE	DIP SWITCH TYPE RANGE 6 7 8 9 10	TEMPERATURE & mV RANGE	RANGE ACCURACY	WIRE COLOR	
					ANSI	BS1843
J	0	0 0 0 0 0	-136 to 111°C	$\pm 0.19^\circ\text{C}$	White (+) Red (-)	Yellow (+) Blue (-)
	1	0 0 0 0 1	69 to 575°C	$\pm 0.38^\circ\text{C}$		
	2	0 0 0 1 0	338 to 800°C	$\pm 0.35^\circ\text{C}$		
	3	0 0 0 1 1	-149 to 862°C	$\pm 0.76^\circ\text{C}$		
K	0	0 0 1 0 0	-200 to 541°C	$\pm 0.56^\circ\text{C}$	Yellow (+) Red (-)	Brown (+) Blue (-)
	1	0 0 1 0 1	427 to 1132°C	$\pm 0.53^\circ\text{C}$		
	2	0 0 1 1 0	648 to 1372°C	$\pm 0.54^\circ\text{C}$		
	3	0 0 1 1 1	-192 to 1372°C	$\pm 1.17^\circ\text{C}$		
T	0	0 1 0 0 0	-225 to 149°C	$\pm 0.28^\circ\text{C}$	Blue (+) Red (-)	White (+) Blue (-)
	1	0 1 0 0 1	74 to 326°C	$\pm 0.19^\circ\text{C}$		
	2	0 1 0 1 0	68 to 400°C	$\pm 0.25^\circ\text{C}$		
	3	0 1 0 1 1	-200 to 400°C	$\pm 0.45^\circ\text{C}$		
E	0	0 1 1 0 0	-111 to 311°C	$\pm 0.32^\circ\text{C}$	Violet (+) Red (-)	Brown (+) Blue (-)
	1	0 1 1 0 1	276 to 609°C	$\pm 0.25^\circ\text{C}$		
	2	0 1 1 1 0	377 to 1000°C	$\pm 0.47^\circ\text{C}$		
	3	0 1 1 1 1	-114 to 1000°C	$\pm 0.84^\circ\text{C}$		
mV	0	1 1 1 0 0	-9 to 6 mV	$\pm 0.0113 \text{ mV}$	N/A	N/A
	1	1 1 1 0 1	-9 to 22 mV	$\pm 0.0233 \text{ mV}$		
	2	1 1 1 1 0	-9 to 63 mV	$\pm 0.0540 \text{ mV}$		
	3	1 1 1 1 1	-9 to 77 mV	$\pm 0.0645 \text{ mV}$		

Note: DIP switch settings ON = 1 OFF = 0

**Accuracy Example:**  
Type "J" Range "0"  
-136°C to 111°C

Range	Conformity	Ice Point	Total Error
( $\pm 0.19^\circ\text{C}$ + $\pm 0.25^\circ\text{C}$ + $\pm 0.50^\circ\text{C}$ )			= $\pm 0.94^\circ\text{C}$

- TC BREAK DETECTION:** Upscale to 22.5 mA (nominal) or Downscale to 3.6 mA (nominal) [selectable via DIP switch]

### Output Specifications

- OUTPUT:** 4 to 20 mA Linear output with Temperature or mV input.  
**Ripple:** Less than 15 mV peak-to-peak max., across 250 $\Omega$  load resistor (up to 120 Hz frequencies).
- RESPONSE TIME:** 400 msec (to within 99% of final value w/step input; typically, response is limited to response time of probe.)

### Ordering Information

MODEL NO.	DESCRIPTION	PART NUMBER
ITMA	Intelligent Thermocouple Module	ITMA2003



## MODEL ITMA DC - INTELLIGENT THERMOCOUPLE MODULE WITH ANALOG OUTPUT



- USER PROGRAMMABLE INPUT (Thermocouple types J, K, T, & E, or Millivolt)
- MICROPROCESSOR CONTROLLED
- SIMPLE ADJUSTABLE RANGE SETTING (Using Input Signal)
- THERMOCOUPLE BREAK DETECTION
- MOUNTS ON "T" AND "G" STYLE DIN RAILS
- 3-WAY ELECTRICAL ISOLATION (POWER/INPUT/OUTPUT)
- MULTIPLE ANALOG OUTPUTS (0 to 20 mA, 4 to 20 mA, and 0 to 10 VDC)
- WIDE OPERATING TEMPERATURE RANGE (-25°C to 75°C)
- POWER & MEMORY ERROR INDICATION
- 9 to 32 VDC POWERED



EMC COMPLIANT



ANALOG OUTPUT

Click Icon For User Bulletin



FAX/WEB  
DOC# 10011

### Product Features

The ITMA accepts a thermocouple or millivolt input and converts it into a voltage or current output. The voltage or current output is linearly proportional to the temperature or millivolt input. This output is ideal for interfacing to indicators, chart recorders, controllers, or other instrumentation equipment.

The ITMA is DC powered. The DC power input is isolated from the signal input and analog output. The unit scales the analog output proportionally to the thermocouple or millivolt input signal. The analog output may be configured for one of the following: 0 to 20 mA, 4 to 20 mA, or 0 to 10 VDC. Making the signal conversion with the ITMA to a current output signal, makes the signal less susceptible to noise interference and allows accurate transmission over long distances. The 3-Way isolation allows the use of grounded thermocouples which can provide additional noise reduction benefits.

The ITMA uses a ten position DIP switch to accomplish the input sensor configuration, range selection, and unit calibration. A simple range setting technique (Field Calibration) is used so the actual input signal adjusts the output for scaling. This technique eliminates the need for potentiometers which are vulnerable to changes due to vibration.

The unit is equipped with a universal mounting foot for attachment to standard DIN style mounting rails, including top hat rail (T) according to EN 50 022 - 35 x 7.5 and -35 x 15, and (G) profile according to EN 50 035 - G 32.

### DIMENSIONS "In Inches (mm)"

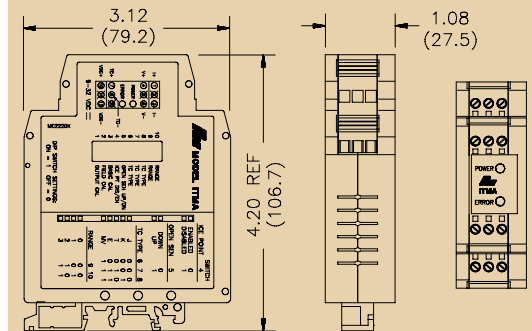

### General Specifications

1. **POWER:** 9 to 32 VDC; 1.75 W The power supply must have 300 mA for 200 msec. surge capacity.
2. **DIELECTRIC WITHSTAND VOLTAGE:** 1500 VAC for 1 minute  
**Working Voltage:** 50 VAC  
Power input to Signal input, Power input to Signal output, & Signal input to Signal output.
3. **ENVIRONMENTAL CONDITIONS:**  
**Operating Temperature Range:** -25°C to 75°C (-13°F to 167°F)  
**Storage Temperature Range:** -40 to 85°C (-40°F to 185°F)  
**Operating and Storage Humidity:** 85% max. (non-condensing) from -25°C to 75°C.  
**Altitude:** Up to 2000 meters
4. **MOUNTING:** Universal mounting foot for attachment to standard DIN style mounting rails, including top hat (T) profile rail according to EN50022 -35 x 7.5 and -35 x 15, and G profile rail according to EN50035 - G32.
5. **CONNECTION:** Compression type terminal block
6. **CONSTRUCTION:** High impact green plastic case
7. **CERTIFICATIONS AND COMPLIANCES:**  
**SAFETY**  
EN 61010-1, IEC 1010-1  
**ELECTROMAGNETIC COMPATIBILITY**  
Immunity to EN 50082-2  
Emissions to EN 50081-2
8. **WEIGHT:** 4.02 oz. (114.0 g)

## MODEL ITMA DC - INTELLIGENT THERMOCOUPLE MODULE WITH ANALOG OUTPUT

### Input Specifications

- INPUT:** J, K, T, E, mV [selectable via DIP switch]
- TC BREAK DETECTION:** Nominal values shown in the following order:  
(0 to 20 mA, 4 to 20 mA, and 0 to 10 VDC).  
**Upscale:** 22.9 mA, 22.5 mA, and 11.5 VDC  
**Downscale:** -0.5 mA, 3.5 mA, and -0.4 VDC
- TEMPERATURE EFFECTS:**  
**Temperature Coefficient:**  $\pm 0.025\%$  of input range per  $^{\circ}\text{C}$   
**Ice Point Compensation:**  $\pm 0.75^{\circ}\text{C}$  for a  $50^{\circ}\text{C}$  change in temperature
- RANGE & ACCURACY:** (12 Bit resolution)  
**Accuracy:**  $\pm ( 0.075\% \text{ Range} + 0.25^{\circ}\text{C} [\text{Conformity}] + 0.50^{\circ}\text{C} [\text{Ice Point}] )$   
at  $23^{\circ}\text{C}$  after 20 min. warm-up, conforming to ITS-90.  
*Note: TC Conformity and Ice Point do not apply to mV input*  
**Relative Humidity:** Less than 85% RH (non-condensing)  
**Span:** The input span can be set to a min. of 1/8 of the full scale range, anywhere within that range.

Thermocouple Accuracy for each type and the corresponding ranges:

TC (INPUT)	RANGE	DIP SWITCH TYPE RANGE 6 7 8 9 10	TEMPERATURE & mV RANGE	RANGE ACCURACY	WIRE COLOR	
					ANSI	BS1843
J	0	0 0 0 0 0	-136 to 111 $^{\circ}\text{C}$	$\pm 0.19^{\circ}\text{C}$	White (+) Red (-)	Yellow (+) Blue (-)
	1	0 0 0 0 1	69 to 575 $^{\circ}\text{C}$	$\pm 0.38^{\circ}\text{C}$		
	2	0 0 0 1 0	338 to 800 $^{\circ}\text{C}$	$\pm 0.35^{\circ}\text{C}$		
	3	0 0 0 1 1	-149 to 862 $^{\circ}\text{C}$	$\pm 0.76^{\circ}\text{C}$		
K	0	0 0 1 0 0	-200 to 541 $^{\circ}\text{C}$	$\pm 0.56^{\circ}\text{C}$	Yellow (+) Red (-)	Brown (+) Blue (-)
	1	0 0 1 0 1	427 to 1132 $^{\circ}\text{C}$	$\pm 0.53^{\circ}\text{C}$		
	2	0 0 1 1 0	648 to 1372 $^{\circ}\text{C}$	$\pm 0.54^{\circ}\text{C}$		
	3	0 0 1 1 1	-192 to 1372 $^{\circ}\text{C}$	$\pm 1.17^{\circ}\text{C}$		
T	0	0 1 0 0 0	-225 to 149 $^{\circ}\text{C}$	$\pm 0.28^{\circ}\text{C}$	Blue (+) Red (-)	White (+) Blue (-)
	1	0 1 0 0 1	74 to 326 $^{\circ}\text{C}$	$\pm 0.19^{\circ}\text{C}$		
	2	0 1 0 1 0	68 to 400 $^{\circ}\text{C}$	$\pm 0.25^{\circ}\text{C}$		
	3	0 1 0 1 1	-200 to 400 $^{\circ}\text{C}$	$\pm 0.45^{\circ}\text{C}$		
E	0	0 1 1 0 0	-111 to 311 $^{\circ}\text{C}$	$\pm 0.32^{\circ}\text{C}$	Violet (+) Red (-)	Brown (+) Blue (-)
	1	0 1 1 0 1	276 to 609 $^{\circ}\text{C}$	$\pm 0.25^{\circ}\text{C}$		
	2	0 1 1 1 0	377 to 1000 $^{\circ}\text{C}$	$\pm 0.47^{\circ}\text{C}$		
	3	0 1 1 1 1	-114 to 1000 $^{\circ}\text{C}$	$\pm 0.84^{\circ}\text{C}$		
mV	0	1 1 1 0 0	-9 to 6 mV	$\pm 0.0113 \text{ mV}$	N/A	N/A
	1	1 1 1 0 1	-9 to 22 mV	$\pm 0.0233 \text{ mV}$		
	2	1 1 1 1 0	-9 to 63 mV	$\pm 0.0540 \text{ mV}$		
	3	1 1 1 1 1	-9 to 77 mV	$\pm 0.0645 \text{ mV}$		

Note: DIP switch settings ON = 1 OFF = 0

Accuracy Example:  
Type "J" Range "0"  
-136 $^{\circ}\text{C}$  to 111 $^{\circ}\text{C}$

Range	Conformity	Ice Point	Total Error
( $\pm 0.19^{\circ}\text{C}$ +	$\pm 0.25^{\circ}\text{C}$ +	$\pm 0.50^{\circ}\text{C}$ ) =	$\pm 0.94^{\circ}\text{C}$

### Output Specifications

- OUTPUT:** All output signals scaled linearly using temperature or mV input. Unit is shipped for 4 to 20 mA output. 4 to 20 mA or 0 to 20 mA selected via internal jumper.  
**Voltage Output Compliance:**  
0 to 10 VDC across min 2 K $\Omega$  load (5 mA)  
20 mV peak to peak max. ripple (for frequencies up to 120 Hz)  
**Current Output Compliance:**  
0 to 20 mA through max. 600 $\Omega$  load (12 VDC)  
4 to 20 mA through max. 600 $\Omega$  load (12 VDC)  
15 mV peak to peak max. ripple across 600 $\Omega$  load (for frequencies up to 120 Hz)
- RESPONSE TIME:** 400 msec (to within 99% of final value w/step input; typically, response is limited to response time of probe.)

### Ordering Information

MODEL NO.	DESCRIPTION	PART NUMBER
ITMA	Intelligent Thermocouple Module	ITMA3035

## MODEL IRMA - INTELLIGENT RTD MODULE WITH ANALOG OUTPUT

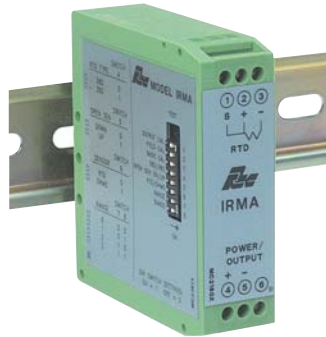

- USER PROGRAMMABLE INPUT (RTD alpha=0.00385 (DIN 43760), alpha=0.00392, or resistance)
- 12 to 42 VDC LOOP POWERED (4 to 20 mA Output)
- MICROPROCESSOR CONTROLLED
- SIMPLE ADJUSTABLE RANGE SETTING (Using Input Signal)
- RTD BREAK DETECTION
- MOUNTS ON "T" AND "G" STYLE DIN RAILS
- 2-WAY ELECTRICAL ISOLATION (INPUT/OUTPUT & POWER)
- HIGH-DENSITY PACKAGING (22.5 mm wide)
- WIDE OPERATING TEMPERATURE RANGE



Click Icon For User Bulletin



### Product Features

The IRMA accepts a 2, 3, or 4 wire RTD or resistance input and converts it into a 4 to 20 mA current output. The 4 to 20 mA output is linearly proportional to the temperature or the resistance input. This output is ideal for interfacing to indicators, chart recorders, controllers, or other instrumentation equipment.

The IRMA is loop-powered which means that the same two wires are carrying both the power and the output signal. The unit controls the output current draw from 4 to 20 mA in direct proportion to the input while consuming less than 4 mA for operation. The conversion to a current output signal makes the IRMA less susceptible to noise interference and allows accurate transmission over long distances. Two-Way isolation allows the use of grounded RTD's which can provide additional noise reduction benefits.

The IRMA uses an eight position DIP switch to accomplish the input sensor configuration, range selection, and unit calibration. A simple range setting technique (Field Calibration) is used so the actual input signal adjusts the output current for scaling. This technique eliminates the need for potentiometers which are vulnerable to changes due to vibration.

The unit is equipped with a universal mounting foot for attachment to standard DIN style mounting rails, including top hat rail (T) according to EN 50 022 - 35 X 7.5 and 35 X 15, and G profile according to EN 50 035 - G 32.

### DIMENSIONS "In Inches (mm)"

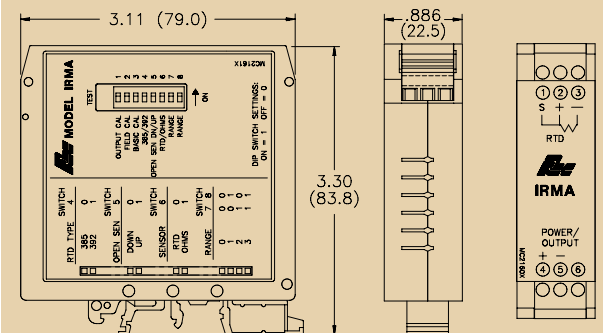

### General Specifications

- POWER:** 12 to 42 VDC \*(Loop powered). The power supply must have a 30 mA min. capacity.  
[\* Min. voltage must be increased to include the drop across any current display indicator]
- ENVIRONMENTAL CONDITIONS:**  
**Operating Temperature Range:** -25°C to 75°C (-13°F to 167°F)  
**Storage Temperature Range:** -40°C to 85°C (-40°F to 185°F)  
**Temperature Coefficient:** ± 0.01% of input range per °C  
**Altitude:** Up to 2000 meters.
- DIELECTRIC WITHSTAND VOLTAGE:** 1500 VAC for 1 minute  
**Working Voltage:** 50 VAC from input to output.
- CERTIFICATIONS AND COMPLIANCES:**  
**SAFETY**  
 EN 61010-1, IEC 1010-1  
**ELECTROMAGNETIC COMPATIBILITY**  
 Immunity to EN 50082-2  
 Emissions to EN 50081-2
- MOUNTING:** Universal mounting foot for attachment to standard DIN style mounting rails, including top hat (T) profile rail according to EN50022-35 x 7.5 and -35 x 15, and G profile rail according to EN50035 - G32.
- CONNECTION:** Compression type terminal block
- CONSTRUCTION:** High impact green plastic case
- WEIGHT:** 2.7 oz (76.54 g)

## MODEL IRMA - INTELLIGENT RTD MODULE WITH ANALOG OUTPUT

### Input Specifications

- INPUT:** RTD 2, 3, or 4 wire, 100 ohm platinum, alpha = 0.00385 (DIN 43760), alpha = 0.00392, or resistance [selectable via DIP switch]  
**Excitation:** 0.170 mA nominal  
**Lead resistance:** Less than 0.5°C with 15 ohms max. per lead  
*Note: There is no lead compensation for 2 wire input. Field calibration should be accomplished with equivalent series resistance.*
- RANGE & ACCURACY:** (12 Bit resolution)  
**Accuracy:**  $\pm$  ( 0.075% Range + 0.1°C [Conformity]) at 23°C after 20 min. warm-up, conforming to ITS-90.  
*Note: RTD conformity does not apply to resistance input.*  
**Relative Humidity:** Less than 85% RH (non-condensing)  
**Span:** The input span can be set to a min. of 1/8 of the full scale range, anywhere within that range.  
**Range Accuracy:**

INPUT	RANGE	DIP SWITCH TYPE RANGE 4 6 7 8	TEMPERATURE & OHMS RANGE	RANGE ACCURACY
RTD alpha = 0.00385	0	0 0 0 0	-160 to 654°C	$\pm$ 0.61°C
	1	0 0 0 1	-108 to 207°C	$\pm$ 0.24°C
	2	0 0 1 0	-5 to 414°C	$\pm$ 0.31°C
	3	0 0 1 1	194 to 608°C	$\pm$ 0.31°C
RTD alpha = 0.00392	0	1 0 0 0	-157 to 640°C	$\pm$ 0.60°C
	1	1 0 0 1	-106 to 203°C	$\pm$ 0.23°C
	2	1 0 1 0	-5 to 406°C	$\pm$ 0.31°C
	3	1 0 1 1	190 to 596°C	$\pm$ 0.30°C
OHMS	0	0 1 0 0	35.5 to 331.0 $\Omega$	$\pm$ 0.222 $\Omega$
	1	0 1 0 1	57.0 to 178.5 $\Omega$	$\pm$ 0.091 $\Omega$
	2	0 1 1 0	98.0 to 252.0 $\Omega$	$\pm$ 0.116 $\Omega$
	3	0 1 1 1	173.5 to 316.5 $\Omega$	$\pm$ 0.107 $\Omega$

Note: DIP switch settings    ON = 1    OFF = 0

- RTD BREAK DETECTION:** Upscale to 22.5 mA (nominal) or Downscale to 3.6 mA (nominal) [selectable via DIP switch]

### Output Specifications

- OUTPUT:** 4 to 20 mA Linear output with Temperature or resistance input.  
**Ripple:** Less than 15 mV peak-to-peak max., across 250 $\Omega$  load resistor (up to 120 Hz frequencies).
- RESPONSE TIME:** 400 msec (to within 99% of final value w/step input; typically, response is limited to response time of probe.)

### Ordering Information

MODEL NO.	DESCRIPTION	PART NUMBER
IRMA	Intelligent RTD Module	IRMA2003

## MODEL IRMA DC - INTELLIGENT RTD MODULE WITH ANALOG OUTPUT



- USER PROGRAMMABLE INPUT (RTD alpha = 0.00385 (DIN 43760), alpha = 0.00392, or resistance)
- MICROPROCESSOR CONTROLLED
- SIMPLE ADJUSTABLE RANGE SETTING (Using Input Signal)
- RTD BREAK DETECTION
- MOUNTS ON "T" AND "G" STYLE DIN RAILS
- 3-WAY ELECTRICAL ISOLATION (POWER/INPUT/OUTPUT)
- MULTIPLE ANALOG OUTPUTS (0 to 20 mA, 4 to 20 mA, and 0 to 10 VDC)
- WIDE OPERATING TEMPERATURE RANGE
- LED INDICATION (POWER & MEMORY ERROR)
- 9 to 32 VDC POWERED

Click Icon For User Bulletin



FAX/WEB  
DOC# 10009

### Product Features

The IRMA accepts an RTD or resistance input and converts it into a voltage or current output. The output is linearly proportional to the temperature or resistance input. This output is ideal for interfacing to indicators, chart recorders, controllers, or other instrumentation equipment.

The IRMA is DC powered. The DC power input is isolated from the signal input and analog output. The unit scales the analog output proportionally to the RTD or resistance input signal. The analog output may be configured for one of the following: 0 to 20 mA, 4 to 20 mA, or 0 to 10 VDC. Making the signal conversion with the IRMA to a current output signal, makes the signal less susceptible to noise interference and allows accurate transmission over long distances. The 3-Way isolation allows the use of grounded RTD's which can provide additional noise reduction benefits.

The IRMA uses an eight position DIP switch to accomplish the input sensor configuration, range selection, and unit calibration. A simple range setting technique (Field Calibration) is used so the actual input signal adjusts the output for scaling. This technique eliminates the need for potentiometers which are vulnerable to changes due to vibration.

The unit is equipped with a universal mounting foot for attachment to standard DIN style mounting rails, including top hat rail (T) according to EN 50 022 -35 x 7.5 and -35 x 15, and (G) profile according to EN 50 035 - G 32.

### DIMENSIONS "In Inches (mm)"

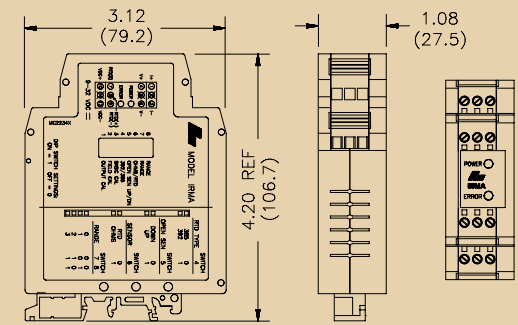

### General Specifications

1. **POWER:** 9 to 32 VDC; 1.75 W. 200 mA max. current. The power supply must have 400 mA for 200 msec. surge capacity.
2. **TEMPERATURE EFFECTS:**  
**Temperature Coefficient:**  $\pm 0.025\%$  of input range per  $^{\circ}\text{C}$
3. **DIELECTRIC WITHSTAND VOLTAGE:** 1500 VAC for 1 minute  
**Working Voltage:** 50 VAC  
Power input to Signal input, Power input to Signal output, & Signal input to Signal output.
4. **CERTIFICATIONS AND COMPLIANCES:**  
**SAFETY**  
EN 61010-1, IEC 1010-1  
**ELECTROMAGNETIC COMPATIBILITY**  
Immunity to EN 50082-2  
Emissions to EN 50081-2
5. **ENVIRONMENTAL CONDITIONS:**  
**Operating Temperature Range:**  $-25^{\circ}\text{C}$  to  $75^{\circ}\text{C}$  ( $-13^{\circ}\text{F}$  to  $167^{\circ}\text{F}$ )  
**Storage Temperature Range:**  $-40$  to  $85^{\circ}\text{C}$  ( $-40^{\circ}\text{F}$  to  $185^{\circ}\text{F}$ )  
**Operating and Storage Humidity:** 85% max. relative humidity (non-condensing) from  $-25^{\circ}\text{C}$  to  $75^{\circ}\text{C}$ .  
**Altitude:** Up to 2000 meters
6. **MOUNTING:** Universal mounting foot for attachment to standard DIN style mounting rails, including top hat (T) profile rail according to EN50022 - 35 x 7.5 and 35 x 15, and G profile rail according to EN50035 - G32.
7. **CONNECTION:** Compression type terminal block
8. **CONSTRUCTION:** High impact green plastic case
9. **WEIGHT:** 4.02 oz. (114.0 g)

## MODEL IRMA DC - INTELLIGENT RTD MODULE WITH ANALOG OUTPUT

### Input Specifications

- INPUT:** RTD 2, 3, or 4 wire, 100 ohm platinum, alpha = 0.00385 (DIN 43760), alpha = 0.00392, or resistance [selectable via DIP switches].  
**Excitation:** 0.170 mA nominal  
**Lead resistance:** Less than 0.5°C with 15 ohms max. per lead  
*Note: There is no lead compensation for 2 wire input. Field calibration should be performed with equivalent series resistance.*
- RTD BREAK DETECTION:** Nominal values shown in the following order: (0 to 20 mA, 4 to 20 mA, and 0 to 10 VDC).  
**Upscale:** 22.9 mA, 22.5 mA, and 11.5 VDC  
**Downscale:** -0.5 mA, 3.5 mA, and -0.4 VDC
- RANGE & ACCURACY:** (12 Bit resolution)  
**Accuracy:**  $\pm (0.075\% \text{ Range} + 0.1^\circ\text{C} [\text{Conformity}])$  at 23°C after 45 min. warm-up, conforming to ITS-90.  
*Note: RTD Conformity does not apply to resistance input. For best accuracy, calibration should be performed under operating conditions.*  
**Relative Humidity:** Less than 85% RH (non-condensing)  
**Span:** The input span can be set to a min. of 1/8 of the full scale range, anywhere within that range.

Range Accuracy:

INPUT	RANGE	DIP SWITCH	TEMPERATURE & OHMS RANGE	RANGE ACCURACY
		TYPE RANGE		
		4 6 7 8		
RTD alpha = 0.00385	0	0 0 0 0	-160 to 654°C	$\pm 0.61^\circ\text{C}$
	1	0 0 0 1	-108 to 207°C	$\pm 0.24^\circ\text{C}$
	2	0 0 1 0	-5 to 414°C	$\pm 0.31^\circ\text{C}$
	3	0 0 1 1	149 to 608°C	$\pm 0.31^\circ\text{C}$
RTD alpha = 0.00392	0	1 0 0 0	-157 to 640°C	$\pm 0.60^\circ\text{C}$
	1	1 0 0 1	-106 to 203°C	$\pm 0.23^\circ\text{C}$
	2	1 0 1 0	-5 to 406°C	$\pm 0.31^\circ\text{C}$
	3	1 0 1 1	-190 to 596°C	$\pm 0.30^\circ\text{C}$
OHMS	0	0 1 0 0	35.5 to 331.0 $\Omega$	$\pm 0.222 \Omega$
	1	0 1 0 1	57.0 to 178.5 $\Omega$	$\pm 0.091 \Omega$
	2	0 1 1 0	98.0 to 252.0 $\Omega$	$\pm 0.116 \Omega$
	3	0 1 1 1	173.5 to 316.5 $\Omega$	$\pm 0.107 \Omega$

Note: DIP switch settings ON = 1 OFF = 0

### Output Specifications

- OUTPUT:** All output signals scaled linearly using temperature or resistance input. Unit is shipped set for the 4 to 20 mA output. 4 to 20 mA or 0 to 20 mA selected via internal jumper.  
**Voltage Output Compliance:**  
 0 to 10 VDC across min. 1 K $\Omega$  load (10 mA)  
 20 mV peak to peak max. ripple (for frequencies up to 120 Hz)  
**Current Output Compliance:**  
 0 to 20 mA through max. 600 $\Omega$  load (12 VDC)
- RESPONSE TIME:** 400 msec. (to within 99% of final value w/step input; typically, response is limited to response time of probe.)  
 4 to 20 mA through max. 600 $\Omega$  load (12 VDC)  
 15 mV peak to peak max. ripple across 600 $\Omega$  load (for frequencies up to 120 Hz)

### Ordering Information

MODEL NO.	DESCRIPTION	PART NUMBER
IRMA	Intelligent RTD Module	IRMA3035

## MODEL ITMS - INTELLIGENT TEMPERATURE TO MODBUS CONDITIONER W/ALARMS



- TEMPERATURE TO MODBUS CONVERSION
- ACCEPTS THERMOCOUPLE, RTD, mV OR RESISTANCE SIGNALS
- PROCESSOR BASED SCALING
- FOUR WAY SIGNAL ISOLATION
- RELAY ALARMS BUILT-IN FOR LOCAL ACTION CAPABILITY



Click Icon For User Bulletin



FAX/WEB  
DOC # 10017

### Product Features

The ITMS4037 Intelligent Temperature to MODBUS™ Conditioner with Alarms accepts a wide range of temperature sensors (thermocouple and RTD elements), and converts the signal into a register format that can be read using either ASCII or RTU MODBUS protocol.

The ITMS allows a choice of either Fahrenheit or Celsius readout with 0.1 or 1 degree of resolution. An offset value can be programmed to scale the input signal to meet most process requirements. Additionally, two setpoint values can be entered for dual relay process monitoring alarms.

The ITMS is programmed with Windows® based SFIMS software. The software allows configuration, calibration, and storage of ITMS program files. Additionally, all setup parameters can be interrogated and modified through MODBUS register and coil commands.

The RS485 port allows the ITMS to be multidropped, with Baud rates up to 38400. The CBPRO007 programming cable converts the RS232 port of a PC to RS485, and is terminated with an RJ-11 connector. The bidirectional capability of the CBPRO007 allows it to be used as a permanent interface cable as well as a programming cable.

The ITMS's two relay alarms can be configured independently for absolute high or low acting with balanced or unbalanced hysteresis. Alarm 2 can also be configured for deviation and band alarms. In these modes, Setpoint 2 tracks Setpoint 1. Adjustable alarm trip delays can be used for delaying output response. The alarms can be programmed for Automatic or Latching. Latched alarms can be reset with a serial command or a user input. A standby feature suppresses the alarm during power-up until the temperature stabilizes outside the alarm region. Standby eliminates power-up tripping for low acting alarms. A user input can be used to set and reset non-latching alarms. The output relays can also be manually controlled with register commands.

The module's high density packaging and DIN rail mounting saves time and panel space. The module is equipped with a universal mounting foot for attachment to standard DIN rails, including top hat (T) profile or G profile rail.

### MODULE ISOLATION

The ITMS features "4-way" signal isolation. The 4-way isolation is a combination of optical, transformer and relay barriers, providing common mode voltage (CMV) isolation to 1.5 KV for 1 minute between input, RS485, and power supply. Isolation between relay contacts and all other inputs is 2300 Vrms for 1 minute.

### DIMENSIONS "In Inches (mm)"

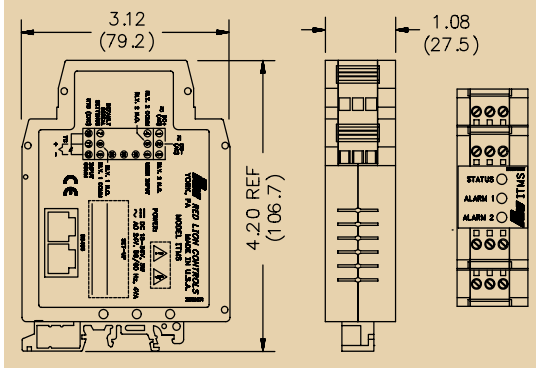

### General Specifications

- POWER:** 18-36 VDC, 3.0 W max. or 24 VAC, ±10%, 50/60 Hz, 4 VA max.
- ISOLATION LEVEL:** 1.5 KV @ 50/60 Hz, 1 minute (150 V working) between input, RS485 and power supply. 2300 Vrms, 1 minute (300 V working) to relay contacts.
- MEMORY:** Nonvolatile E<sup>2</sup>PROM retains all programmable parameters.
- ENVIRONMENTAL CONDITIONS:**
  - Operating Temperature Range:** -20 to +65 °C
  - Storage Temperature Range:** -40 to +85 °C
  - Operating and Storage Humidity:** 85% max. relative humidity (non-condensing) from -20 to +65 °C
  - Altitude:** Up to 2000 meters

## MODEL ITMS - INTELLIGENT TEMPERATURE TO MODBUS CONDITIONER W/ALARMS

### General Specifications Continued

#### 5. CERTIFICATIONS AND COMPLIANCE:

##### SAFETY

EN 61010-1, IEC 1010-1

##### ELECTROMAGNETIC COMPATIBILITY

Immunity to EN 50082-2

Emissions to EN 50081-2

#### 6. CONSTRUCTION:

Case body is green high impact plastic.  
Installation Category II, Pollution Degree 2.

#### 7. CONNECTIONS:

Wire clamping screw terminals.

#### 8. MOUNTING:

Universal mounting foot for attachment to standard DIN style mounting rails, including top hat (T) profile rail according to EN50022 - 35 x 7.5 and -35 x 15, and G profile rail according to EN50035 - G32.

#### 9. WEIGHT:

4.5 oz. (127.57 g)

### Input Specifications

#### 1. INPUT:

**Sample Rate:** 67 msec. (15 Hz)

**Failed Sensor Response:** Open or shorted (RTD only) sensor coils indication, error code returned in Process Value

**Common Mode Rejection:** 50/60 Hz, 110 dB min.

**Overvoltage:** 30 VDC

**Response Time:** 150 msec. max.

#### 2. THERMOCOUPLE INPUTS:

**Types:** T, E, J, K, R, S, B, N, C, linear mV

**Input Impedance:** 20 M $\Omega$

**Lead Resistance Effect:** 0.22  $\mu$ V/ $\Omega$

**Resolution:** 1° or 0.1° for all types

TC TYPE	DISPLAY RANGE	WIRE COLOR	
		ANSI	BS 1843
T	-200 to +400°C -328 to +752°F	(+) blue (-) red	(+) white (-) blue
E	-200 to +750°C -328 to +1382°F	(+) violet (-) red	(+) brown (-) blue
J	-200 to +760°C -328 to +1400°F	(+) white (-) red	(+) yellow (-) blue
K	-200 to +1372°C -328 to +2502°F	(+) yellow (-) red	(+) brown (-) blue
R	0 to +1768°C +32 to +3214°F	No Standard	(+) white (-) blue
S	0 to +1768°C +32 to +3214°F	No Standard	(+) white (-) blue
B	+200 to +1820°C +392 to +3308°F	No Standard	No Standard
N	-200 to +1300°C -328 to +2372°F	(+) orange (-) red	(+) orange (-) blue
C	0 to +2315°C +32 to +4199°F	No Standard	No Standard
W5/W26	-10 mV to 65 mV	NA	NA

#### 3. RTD INPUTS:

**Type:** 2 or 3 wire

**Excitation:** 150  $\mu$ A

**Lead Resistance:** 10  $\Omega$  max.

**Resolution:** 1° or 0.1° for all types

RTD TYPE	INPUT TYPE	RANGE
385	100 $\Omega$ platinum, Alpha=.00385	-200 to +800°C -328 to +1472°F
392	100 $\Omega$ platinum, Alpha=.003919	-200 to +800°C -328 to +1472°F
672	120 $\Omega$ nickel, Alpha=.00672	-80 to +260°C -112 to +500°F
Ohms	Linear Resistance	0 to 440 $\Omega$

#### 4. INDICATION ACCURACY:

$\pm(0.3\%$  of span, +1°C), includes NIST conformity, cold junction effect, A/D conversion errors, tempco and linearization conformity at 23°C after 20 minute warm-up.

**Span Drift (max):** 0.01% /°C

#### 5. USER INPUT:

Internally pulled up to +5 VDC.  $V_{IL}$  = 0.78 V max.,  $V_{IH}$  = 1.8 V min.  $I_{OFF}$  = 9  $\mu$ A max. 30 V max. over voltage continuously.

#### 6. A/D CONVERTER:

16 bit resolution

### Output Specifications

#### 1. SERIAL COMMUNICATIONS:

**Type:** RS485; RTU and ASCII MODBUS modes

**Baud:** 300, 600, 1200, 2400, 4800, 9600, 19200, and 38400

**Format:** 7/8 bit, odd, even and no parity

**Transmit Delay:** Programmable. Transmit Enable (TXEN): (primarily for 20 mA loop converter) open collector  $V_{OH}$  = 10 VDC max.  $V_{OL}$  = 0.5 VDC @ 5 mA max. current limit

#### 2. RELAY OUTPUTS:

**Type:** 1 Form A N.O. contacts, 1 Form C DPDT

**Rating:** 5A @ 30 VDC or 250 VAC max. (resistive)

1/10 HP @ 120 VAC (inductive)

**Response Time:** 155 msec. max. to close including step response, 153 msec. max. to open.

**Output On Delay Time:** Programmable from 0 to 32000 sec  $\pm 0.01\%$  - 1 sec. max.

### Ordering Information

MODEL NO.	DESCRIPTION	PART NUMBER
ITMS	Temperature to MODBUS Conditioner w/Alarms	ITMS4037
SFIMS	PC Configuration Software for Windows	SFIMS
CBPRO	Programming Interface Cable	CBPRO007
CBJ	Cable RJ11 to Unterminated 7 foot length	CBJ11A07
	Cable RJ11 to RJ11 6 inch jumper	CBJ11BD5
	RJ Connector to Terminal Adapter	DRRJ11T6



## MODEL IFMA - DIN-RAIL FREQUENCY TO ANALOG CONVERTER



- SIMPLE ON-LINE RANGE SETTING  
(Using Actual Input Signal or Signal Generator)
- USER SETTABLE FULL SCALE FREQUENCY FROM 1 Hz to 25 KHz
- FOUR OUTPUT OPERATING RANGES  
(0 to 5 V, 0 to 10 V, 0 to 20 mA, and 4 to 20 mA)
- PROGRAMMABLE INPUT CIRCUIT ACCEPTS OUTPUTS FROM A VARIETY OF SENSORS
- 85 to 250 VAC and 9 to 32 VDC POWERED VERSIONS AVAILABLE
- LOW FREQUENCY CUT-OUT AND OVERRANGE INDICATION
- 3-WAY ELECTRICAL ISOLATION (POWER/INPUT/OUTPUT)
- INPUT AND OUTPUT INDICATION LED'S



UL RECOGNIZED  
USA



UL RECOGNIZED  
CANADA



EMC  
COMPLIANT



ANALOG  
OUTPUT

Click Icon For  
User Bulletin



FAX/WEB  
DOC# 10006

### Product Features

The Model IFMA accepts a frequency input, and outputs an analog voltage or current in proportion to the input frequency, with 0.1% accuracy. The full scale input frequency can be set to any value from 1 Hz to 25 KHz, either with a frequency source, or digitally with the on-board rotary switch and push-button.

The IFMA utilizes a seven position DIP switch, a rotary switch, a push button and two indication LED's to accomplish input circuit configuration, operational parameter set-up, and Input/Output indication. The input circuitry is DIP switch selectable for a variety of sources.

The indication LED's are used during normal operation to display the input and output status of the IFMA. These LED's are also used to provide visual feedback to the user of the existing parameter settings during parameter set-up.

The IFMA operates in one of four output modes. The programmable minimum and maximum response times provide optimal response at any input frequency.

The unit is equipped with a universal mounting foot for attachment to standard DIN style mounting rails, including top hat profile rail according to EN 50 022 -35 x7.5 and -35 x 15, and G profile rail according to EN 50 035 - G 32.

### DIMENSIONS "In Inches (mm)"

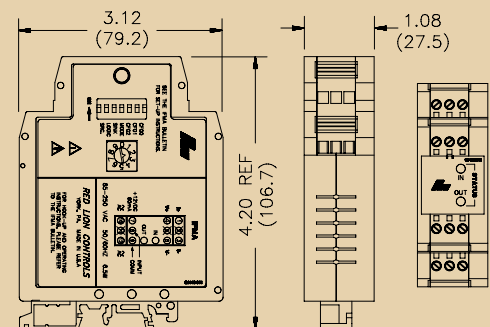

### General Specifications

- POWER:**  
**AC Operation:** 85 to 250 VAC, 48 to 62 Hz; 6.5 VA  
**DC Operation:** 9 to 32 VDC; 2.5 W  
**Power Up Current:**  $I_p = 600$  mA for 50 msec. max.
- SENSOR POWER:** (AC version only) +12 VDC  $\pm 25\%$  @ 60 mA max.
- INPUT AND POWER CONNECTIONS:** Screw in terminal blocks.
- ISOLATION BREAKDOWN VOLTAGE (Dielectric Withstand):** 2200 V between power & input, and power & output; 500 V between input & output for 1 minute.
- CERTIFICATIONS AND COMPLIANCES:**  
**SAFETY**  
 EN 61010-1, IEC 1010-1  
 UL Recognized Component, File #E179259  
 Recognized to U.S. and Canadian requirements under the Component Recognition Program of Underwriters Laboratories, Inc.

### ELECTROMAGNETIC COMPATIBILITY

- Immunity to EN 50082-2
  - Emissions to EN 50081-2
- ENVIRONMENTAL CONDITIONS:**  
**Operating Temperature:** 0 to 50°C  
**Storage Temperature:** -40 to 80°C  
**Operating and Storage Humidity:** 85% max. (non-condensing) from 0°C to 50°C.  
**Altitude:** Up to 2000 meters
  - CONSTRUCTION:**  
 Case body is green, high impact plastic. Installation Category II, Pollution Degree 2
  - WEIGHT:** 6 oz. (0.17 Kg)

### MODEL IFMA - DIN-RAIL FREQUENCY TO ANALOG CONVERTER

#### Input Specifications

- OPERATING FREQUENCY RANGE:**  
From 0 Hz to 25 KHz; user selectable.
- SIGNAL INPUT:** DIP switch selectable to accept signals from a variety of sources, including switch contacts, outputs from CMOS or TTL circuits, magnetic pickups, and all standard RLC sensors.  
**Current Sourcing:** Internal 1 K $\Omega$  pull-down resistor for sensors with current sourcing output. (Max. sensor output current = 12 mA @ 12 V output.)  
**Current Sinking:** Internal 3.9 K $\Omega$  pull-up resistor for sensors with current sinking output. (Max. sensor current = 3 mA.)
- Low Bias:** Input trigger levels  $V_{IL} = 0.25$  V,  $V_{IH} = 0.75$  V; for increased sensitivity when used with magnetic pickups.  
**Hi Bias:** Input trigger levels  $V_{IL} = 2.5$  V,  $V_{IH} = 3.0$  V; for logic level signals.  
**Max. Input Signal:**  $\pm 90$  V; 2.75 mA max. (With both Current Sourcing and Current Sinking resistors switched off.)
- ACCURACY:**  $\pm 0.1\%$  of full scale range ( $\pm 0.2\%$  for 0 to 5 VDC range).
- INPUT IMPEDANCE:** 33 K $\Omega$  min. with the sink and source DIP switches in the OFF position.

#### Output Specifications

- SIGNAL VOLTAGE OUTPUT (Selectable):**  
0 to 5 VDC @ 10 mA max.  
0 to 10 VDC @ 10 mA max.
- SIGNAL CURRENT OUTPUT (Selectable):**  
0 to 20 mA @ 10 VDC min.  
4 to 20 mA @ 10 VDC min.
- OUTPUT COMPLIANCE:**  
**Voltage:** 10 V across a min. 1K $\Omega$  load (10 mA). Factory calibrated for loads greater than 1 M $\Omega$ .  
**Current:** 20 mA through a max. 500 $\Omega$  load (10 VDC).
- ACCURACY:**  $\pm 0.1\%$  of full scale range ( $\pm 0.2\%$  for 0 to 5 VDC range).
- RESOLUTION:**  
**Voltage:** 3.5 mV min.  
**Current:** 5  $\mu$ A min.
- RESPONSE TIME:** 5 msec +1 period to 10 sec +1 period; user selectable

#### Ordering Information

MODEL NO.	DESCRIPTION	PART NUMBERS FOR AVAILABLE SUPPLY VOLTAGES	
		9 to 32 VDC	85 to 250 VAC
IFMA	Pulse Rate to Analog Converter	IFMA0035	IFMA0065

## MODEL IFMR - DIN-RAIL SPEED SWITCH



- SIMPLE ON-LINE TRIP FREQUENCY SETTING (USING ACTUAL INPUT SIGNAL OR FREQUENCY GENERATOR)
- USER SETTABLE TRIP FREQUENCY FROM 0.1 Hz to 25 KHz
- OVER-SPEED, UNDER-SPEED, AND ZERO-SPEED DETECTION
- RELAY LATCHING, ALARM OVERRIDE, AND ALARM RESET FUNCTIONS
- PROGRAMMABLE INPUT CIRCUIT ACCEPTS OUTPUTS FROM A VARIETY OF SENSORS
- HYSTERESIS AND OFFSET FUNCTIONS AVAILABLE
- 85 to 250 VAC and 9 to 32 VDC VERSIONS AVAILABLE
- INPUT AND RELAY STATUS INDICATION LED'S



UL RECOGNIZED  
USA



UL RECOGNIZED  
CANADA



EMC  
COMPLIANT



ALARMS

Click Icon For  
User Bulletin



FAX/WEB  
DOC # 10007

### Product Features

The Model IFMR accepts a frequency input, and controls a single relay (SPDT) based on the value of the input frequency. The Trip frequency can be set to any value from 0.1 Hz to 25 KHz. The IFMR can be set to trip on overspeed, or underspeed (including zero speed). Offset and hysteresis values can be incorporated into the trip setting to eliminate output chatter. LED indicators for both the Input signal and the Relay status are provided. Two separate input connections for external push-buttons are also provided. One external input overrides the trip detection function, and holds the relay in the release state as long as the input is pulled to common. The other external input clears a latched trip condition when pulled to common.

The IFMR utilizes a seven position DIP switch, a rotary switch, a push button and two indication LED's to accomplish input circuit configuration, operational parameter set-up, input signal, and relay status indication. The input circuitry is DIP switch selectable for a variety of sources.

The indication LED's are used during normal operation to display the input signal and relay status of the IFMR. These LED's are also used to provide visual feedback to the user of the current parameter settings during parameter set-up.

The IFMR operates in one of six output modes, as selected by the user. The programmable Minimum Response Time provides optimum response vs. input filtering for any input frequency. The offset and hysteresis settings provide flexible adjustment of the relay trip and release points.

The unit is equipped with a universal mounting foot for attachment to standard DIN style mounting rails, including top hat profile rail according to EN 50 022 - 35 x 7.5 and 35 x 15, and G profile rail according to EN 50 035 - G32.

### DIMENSIONS "In Inches (mm)"

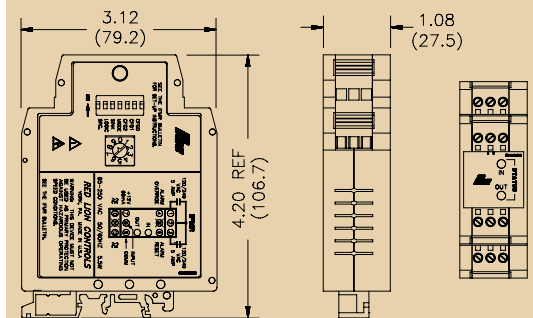

### General Specifications

#### 1. POWER:

**AC Powered Versions:** 85 to 250 VAC; 48 to 62 Hz; 5.5 VA

**DC Powered Versions:** 9 to 32 VDC; 2.0 W

**Power Up Current:**  $I_p = 600$  mA for 50 msec max.

2. **SENSOR POWER:** (AC version only) +12 VDC  $\pm 25\%$  @ 60 mA max.

3. **INPUT AND POWER CONNECTIONS:** Screw in terminal blocks

4. **ISOLATION BREAKDOWN VOLTAGE** (Dielectric Withstand): 2200 V between power & input, and power & output; 500 V between input & output for 1 minute.

#### 5. CERTIFICATIONS AND COMPLIANCES:

##### SAFETY

EN 61010-1, IEC 1010-1

UL Recognized Component, File #E179259

Recognized to U.S. and Canadian requirements under the Component Recognition Program of Underwriters Laboratories, Inc.

#### ELECTROMAGNETIC COMPATIBILITY

Immunity to EN 50082-2

Emissions to EN 50081-2

#### 6. ENVIRONMENTAL CONDITIONS:

**Operating Temperature:** 0 to 50°C

**Storage Temperature:** -40 to 80°C

**Operating and Storage Humidity:** 85% max. relative humidity (non-condensing) from 0°C to 50°C.

**Altitude:** Up to 2000 meters

#### 7. CONSTRUCTION:

Case body is green, high impact plastic. Installation Category II, Pollution Degree 2

#### 8. WEIGHT: 6 oz. (0.17 Kg)

## MODEL IFMR - DIN-RAIL SPEED SWITCH

### Input Specifications

- OPERATING FREQUENCY RANGE:** 0 Hz to 25 KHz
- SIGNAL INPUT:** DIP switch selectable to accept signals from a variety of sources, including switch contacts, outputs from CMOS or TTL circuits, magnetic pickups, and all standard RLC sensors.  
**Current Sourcing:** Internal 1 K $\Omega$  pull-down resistor for sensors with current sourcing output. (*Max. sensor output current = 12 mA @ 12 V output.*)  
**Current Sinking:** Internal 3.9 K $\Omega$  pull-up resistor for sensors with current sinking output. (*Max. sensor current = 3 mA.*)  
**Low Bias:** Input trigger levels  $V_{IL} = 0.25$  V,  $V_{IH} = 0.75$  V; for increased sensitivity when used with magnetic pickups.  
**Hi Bias:** Input trigger levels  $V_{IL} = 2.5$  V,  $V_{IH} = 3.0$  V; for logic level signals.  
**Max. Input Signal:**  $\pm 90$  V; 2.75 mA max. (with both Current Sourcing and Current Sinking resistors switched off).
- CONTROL INPUTS:** Active low ( $V_{IL} = 0.5$  V max.) internally pulled up to 5 VDC through a 100 K $\Omega$  resistor ( $I_{SNK} = 50$   $\mu$ A). Response Time = 1 msec.  
**Alarm Reset:** Unlatches the relay when pulled to common while the input frequency is in the release region.  
**Alarm Override:** Causes the IFMR to unconditionally release the relay when pulled to common.
- ACCURACY:**  $\pm 0.1\%$  of the trip frequency setting.
- INPUT IMPEDANCE:** 33K $\Omega$  min. with the sink and source DIP switches in the OFF positions.
- MINIMUM RESPONSE TIME:** From 5 msec. +1 period to 10 sec. +1 period in ten steps (*excluding relay operate time*).

### Output Specifications

- RELAY CONTACT OUTPUT:** FORM "C" (SPDT) contacts max. rating 5 A @ 120/240 VAC or 28 VDC (*resistive load*), 1/8 H.P. @120 VAC (*inductive load*). The operate time is 5 msec nominal and the release time is 3 msec nominal.
- HYSTERESIS AND OFFSET:** From 0.25% to 33.33% of Trip Frequency in nine steps. Hysteresis and/or Offset can also be set to 0 (*Disabled*).

### Ordering Information

MODEL NO.	DESCRIPTION	PART NUMBERS FOR AVAILABLE SUPPLY VOLTAGES	
		9 to 32 VDC	85 to 250 VAC
IFMR	Speed Switch	IFMR0036	IFMR0066

## MODEL PRS1 - PLUG-IN SPEED SWITCH



- 5 RANGES, FROM .1Hz to 10 KHz
- OVER-SPEED, UNDER-SPEED, OR ZERO-SPEED DETECTION
- 4 OPERATING MODES
- REPEATABILITY TO 1/2% OF MAX. RANGE
- L.E.D. RELAY "ON" INDICATOR
- PROGRAMMABLE INPUT CIRCUIT ACCEPTS OUTPUTS FROM A VARIETY OF SENSORS



Click Icon For User Bulletin



FAX/WEB  
DOC # 12013

### Product Features

The PRS1 is a versatile, reliable and economical solution to most machine speed switching problems. It is not affected by overspeeding and will operate in either direction of rotation.

The heart of the PRS1 is a solid-state CMOS logic circuit, that continuously measures the elapsed time between successive trailing edges (*negative going*) of an incoming pulse train or waveform. It compares this time with an adjustable set-point reference and determines if the period of the waveform is longer (*underspeed*) or shorter (*overspeed*) than the set-point reference.

The internal relay is energized during "normal" operation and can be set to de-energize on either under or overspeed by a programming switch. The unit can be connected for simple over or underspeed detection or for latch/trip-off operation in a machine STOP/START circuit.

The PRS1 features built-in hysteresis (*differential between pick-up and drop-out*) of 5% of set-point speed. This prevents the output relay from chattering when operating at or near the set-point speed. The set-point control is a 20-turn screwdriver adjustment accessible at the top of the unit with a 10:1 adjustment range. An L.E.D. indicates when the relay is energized. A built-in +12 VDC regulated power supply, furnished power for the internal circuit and for external sensor excitation.

The plug-in module mates with a heavy duty, CSA approved base mounting socket with pressure clamp screw terminals that accept stripped wires without lugs. Closed back construction allows mounting directly on metal panel without an insulation barrier.

### DIMENSIONS "In Inches (mm)"

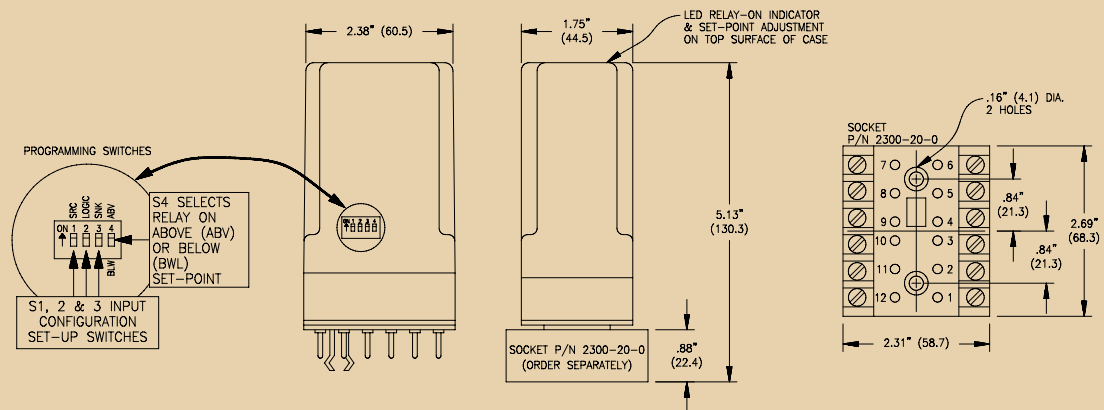

## MODEL PRS1 - PLUG-IN SPEED SWITCH

### General Specifications

- PRIMARY SUPPLY VOLTAGE:** Available for 115 or 230 VAC  $\pm 10\%$ , 50/60 Hz; 2.5 VA (See *Ordering Information*).
- SENSOR OUTPUT POWER:** +12 VDC  $\pm 5\%$  regulated, 60 mA max.
- OPERATING TEMPERATURE RANGE:** 0 to 60°C.
- WEIGHT:** PRS1 PLUG-IN MODULE - 8 oz (226.8 g).

### Input Specifications

- SIGNAL INPUT:** DIP switch selectable to accept signals from a variety of sources, including switch contacts, outputs from CMOS or TTL circuits, magnetic pickups, and all standard RLC sensors.  
**Current Sourcing:** Internal 1 K $\Omega$  pull-down resistor for sensors with current sourcing output. (*Max. sensor output current = 12 mA @ 12 V output.*)  
**Current Sinking:** Internal 3.9 K $\Omega$  pull-up resistor for sensors with current sinking output. (*Max. sensor current = 3 mA.*)  
**Low Bias:** Input trigger levels  $V_{IL} = 0.25$  V,  $V_{IH} = 0.75$  V; for increased sensitivity when used with magnetic pickups.  
**Hi Bias:** Input trigger levels  $V_{IL} = 2.5$  V,  $V_{IH} = 3.0$  V; for logic level signals.  
**Max. Input Signal:**  $\pm 90$  V; (with both Current Sourcing and Current Sinking resistors switched off).
- INPUT IMPEDANCE:** 1 M $\Omega$  min. with the sink and source DIP switches in the OFF positions.
- FREQUENCY RANGES AVAILABLE:** Available in 5 ranges, each range providing a relay pick-up or drop-out adjustment span of 10:1. (See *Ordering Information*)

### Output Specifications

- RELAY CONTACT OUTPUT:** FORM "C" (SPDT) contacts max. rating 5 amps @ 120/240 VAC or 28 VDC (*resistive load*), 1/8 H.P. @ 120 VAC (*inductive load*). The operate time is 5 msec nominal and the release time is 3 msec nominal.
- RELAY LIFE EXPECTANCY:** 100,000 cycles at max. rating. (*As load level decreases, life expectancy increases.*)
- RESPONSE TIME:** Response time is equivalent to the period of set-point frequency, plus 5 msec for relay pickup or plus 3 msec for relay dropout.

### Ordering Information

MODEL NO.	DESCRIPTION	A.C POWER	PART NUMBERS FOR AVAILABLE SUPPLY VOLTAGES				
			0.1-1 Hz	1-10 Hz	10-100 Hz	100-1 KHz	1 K-10 KHz
PRS1	Speed Switch	115VAC	PRS10011	PRS10101	PRS11011	PRS11021	PRS11031
		230VAC	PRS10012	PRS10102	PRS11012	PRS11022	PRS11032
—	Socket, 12-Pin		2300200				

## MODEL PRA1 - PULSE RATE TO ANALOG CONVERTER



- DELIVERS ANALOG OUTPUT PROPORTIONAL TO INPUT PULSE-RATE (Frequency)
- ACCEPTS VARIABLE PULSE-RATE INPUTS FROM A WIDE VARIETY OF SENSORS
- DUAL SIGNAL OUTPUT, 0 to 10 VDC PLUS SELECTABLE SIGNAL CURRENT OUTPUT OF 0 to 1 mA OR 4 to 20 mA
- AVAILABLE IN 5 FREQUENCY RANGE RATINGS FROM 30 Hz to 10 KHz
- ACCURACY (Linearity) 0.25%



Click Icon For User Bulletin



FAX/WEB  
DOC # 12012

### Product Features

The Model PRA1 is a convenient plug-in module that provides voltage and current analog output signals proportional to the pulse-rate (*frequency*) of the input signal. In typical applications the PRA1 input is supplied by a machine mounted sensor that generates a signal which has a frequency proportional to machine or process speed. The PRA1 converts the frequency content of this signal to analog form for operating chart recorders, supplying speed control signals, or driving other controls and indicators that require analog input.

The PRA1 develops an internal "constant-area" pulse from the trailing (*negative going*) edge of each input pulse or wave form cycle. These "Constant-area" pulses are fixed in voltage amplitude and time duration. The PRA1 then takes the average of a train of these pulses to generate an output voltage level proportional to the frequency. Another circuit within the PRA1 monitors the voltage output and produces a current output signal that will deliver either 0 to 1 or 4 to 20 mA, as determined by a set-up switch.

These units are available in five overlapping adjustable range ratings, each rating providing a calibration adjustment to deliver maximum output over an input frequency range of approximately 3.3:1. Since the PRA1 develops an output by averaging pulses,

an inherent response time is involved (*See response table, next page*). The minimum response time is fixed for each range rating. It is longest for the lowest range rating and decreases as the frequency range rating increases. Response time must be considered, when using the PRA1 to provide closed-loop speed feedback signals, to avoid stability problems. For speed feedback applications it is usually advisable to select a high frequency range unit coupled with an appropriate sensor arrangement that delivers a high pulse rate.

The internal filtering supplied for averaging purposes is kept to a minimum in order to provide the fastest practical response time for each range rating.

Additional external capacitance can be added to provide more filtering if required.

The plug-in module mates with a heavy duty, CSA approved base mounting socket with pressure clamp screw terminals that accept stripped wires without lugs. Closed back construction allows mounting directly on metal panel without an insulation barrier.

*Note: Not recommended for closed loop speed control. Refer to the RLC Catalog for the MDC - Motor Drive Controller.*

### DIMENSIONS "In Inches (mm)"

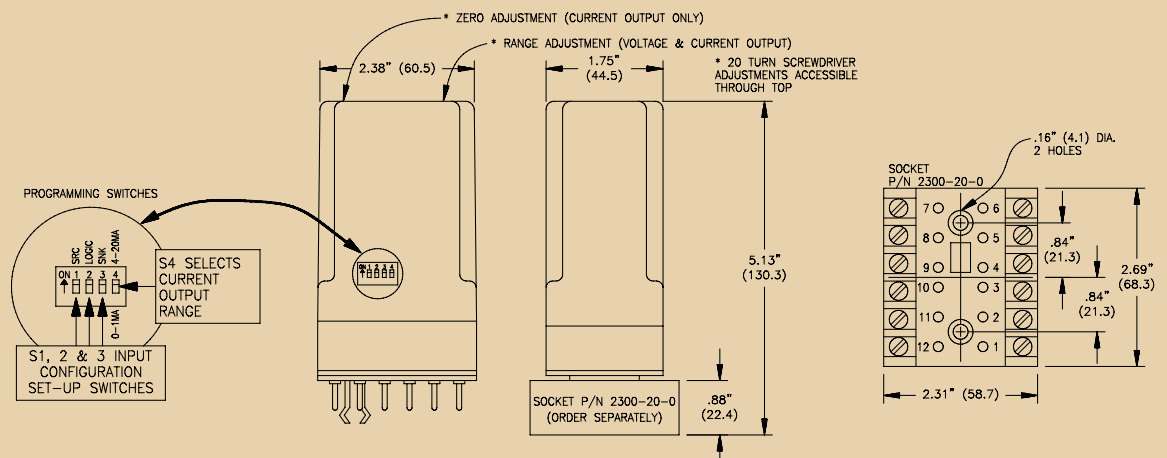

### MODEL PRA1 - PULSE RATE TO ANALOG CONVERTER

#### General Specifications

- PRIMARY SUPPLY VOLTAGE:** Available for 115 or 230 VAC  $\pm 10\%$ , 50/60 Hz; 2.5 VA (See *Ordering Information*).
- SENSOR OUTPUT POWER:** +12 VDC  $\pm 5\%$  regulated, 60 mA max.
- OPERATING TEMPERATURE RANGE:** 0 to 60°C.
- WEIGHT:**  
**PRA1 Plug-in Module:** 8 oz (226.8 g);  
**Mating 12-Pin Socket:** 2 oz (56.7 g).

#### Input Specifications

- OPERATING FREQUENCY RANGE:**  
From 30 Hz to 10 KHz; (See *Ordering Information*).
  - SIGNAL INPUT:** DIP switch selectable to accept signals from a variety of sources, including switch contacts, outputs from CMOS or TTL circuits, magnetic pickups, and all standard RLC sensors.  
**Current Sourcing:** Internal 1 K $\Omega$  pull-down resistor for sensors with current sourcing output. (*Max. sensor output current = 12 mA @ 12 V output.*)  
**Current Sinking:** Internal 3.9 K $\Omega$  pull-up resistor for sensors with current sinking output. (*Max. sensor current = 3 mA.*)
  - INPUT IMPEDANCE:** 1 M $\Omega$  min. with the sink and source DIP switches in the OFF position.
- Low Bias:** Input trigger levels  $V_{IL} = 0.25$  V,  $V_{IH} = 0.75$  V; for increased sensitivity when used with magnetic pickups.  
**Hi Bias:** Input trigger levels  $V_{IL} = 2.5$  V,  $V_{IH} = 3.0$  V; for logic level signals.

#### Output Specifications

- SIGNAL CURRENT OUTPUT (Selectable):**  
0 to 1 mA into load resistance range 0 to 4 K $\Omega$ .  
4 to 20 mA into load resistance range 0 to 250  $\Omega$ .
- LINEARITY:**  $\pm 0.25\%$  of full range setting.
- VOLTAGE/CURRENT OUTPUT TRACKING:** Current Signals follow voltage signals within  $\pm 3\%$  of full range setting.
- RESPONSE TIME:**

PART NUMBER	FULL SCALE RANGE ADJUSTMENT		RESPONSE TIME
	MIN	MAX	[1]
PRA1101-1 OR -2	30 Hz	100 Hz	250 msec
PRA1301-1 OR -2	100 Hz	300 Hz	75 msec
PRA1102-1 OR -2	0.3 KHz	1 KHz	25 msec
PRA1302-1 OR -2	1 KHz	3 KHz	10 msec
PRA1103-1 OR -2	3 KHz	10 KHz	8 msec

[1] RESPONSE TIME - Time required for the output to reach 90% of final value when the frequency is instantly changed from 0 to full-scale range frequency.

#### Ordering Information

MODEL NO.	DESCRIPTION	A.C POWER	PART NUMBERS FOR AVAILABLE SUPPLY VOLTAGES				
			30-100 Hz	100-300 Hz	300-1 KHz	1 K-3 KHz	3 K-10 KHz
PRA1	Pulse Rate to Analog Converter	115VAC	PRA11011	PRA13011	PRA11021	PRA13021	PRA11031
		230VAC	PRA11012	PRA13012	PRA11022	PRA13022	PRA11032
—	Socket, 12-Pin		2300200				



## MODEL ICM4 - SERIAL CONVERTER MODULE



- ALLOWS COMMUNICATIONS BETWEEN RS-232 CONTROL EQUIPMENT AND PRODUCTS WITH RS485 SERIAL COMMUNICATIONS
- WIDE DC INPUT POWER RANGE (+9 to 32 VDC)
- HALF DUPLEX (RS485) AND FULL DUPLEX (RS422)
- LED INDICATION FOR RXD, TXD, and POWER
- UNIVERSAL MOUNTING FOOT FOR DIN RAIL INSTALLATION



Click Icon For User Bulletin



FAX/WEB  
DOC # 12010

### Product Features

The ICM4 Serial Converter Module provides the capability of interfacing equipment with RS485 serial communications to equipment with RS-232 communications. Data format of the RS-232 and RS-485 equipment must be the same.

For full duplex (RS422), the DIP switch on the side of the module must be in the RS422 position. For half duplex (RS485), the DIP switch must be in the RS485 position. In half duplex mode, the RS485 driver is enabled using the leading edge of the first character transmitted (RXD input). After the last character transmits, the converter waits one character time (at 9600 baud) to disable the RS485 driver.

There are 3 LED's that can be viewed from the front of the converter module. A green power LED indicates power is on, a red RS232 TXD LED flashes when the module is transmitting, and a green RS232 RXD LED flashes when the module is receiving.

An external DC power source (+9 to 32 VDC) is required to power the ICM4. The external power source and serial communications connections are made via a 12 position removable terminal block located on the front of the module.

The unit is equipped with a universal mounting foot for attachment to standard DIN style mounting rails, including top hat profile rail according to EN 50 022 -35x7.5 and -35x15, and G profile rail according to EN 50 035 - G32.

### DIMENSIONS "In Inches (mm)"

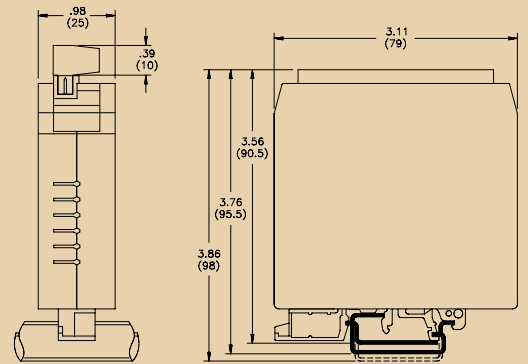

### General Specifications

- POWER:** +9 to 32 VDC @ 75 mA maximum. Above 26 VDC, derate max. operating temperature to 40°C. Power supply must be Class 2 or SELV rated.
- ENVIRONMENTAL CONDITIONS:**  
**Operating Temperature Range:** 0 to 50°C. Derate max. operating temperature to 40°C above 26 VDC.  
**Storage Temperature:** -40 to + 75°C  
**Operating and Storage Humidity:** 85% max.relative humidity (non-condensing) from 0 to 50°C  
**Altitude:** Up to 2000 meters
- CERTIFICATIONS AND COMPLIANCES:**  
**SAFETY**  
 EN 61010-1, IEC 1010-1  
**ELECTROMAGNETIC COMPATIBILITY**  
 Immunity to EN 50082-2  
 Emissions to EN 50081-2
- CONSTRUCTION:** Case body is green, high impact plastic. Installation Category I, Pollution Degree 2.
- MOUNTING:** Standard DIN rail top hat (T) profile rail according to EN50022- 35 X 7.5 and -35 X 15
- WEIGHT:** 3.2 oz. (90.7 g)

## MODEL ICM4 - SERIAL CONVERTER MODULE

### Input/Output Communications

**1. RS-232 VOLTAGES:**

**Receive Data Pin:**  $\pm 30$  VDC max.,

**Mark Condition:**  $\leq 0.8$  VDC

**Space Condition:**  $\geq 2.4$  VDC

**Transmit Data Pin:**

**Mark Condition:**  $-8$  VDC (typ.)

**Space Condition:**  $+8$  VDC (typ.)

**2. RS485 VOLTAGES:**

**Differential Output Voltage:**  $\pm 5$  VDC max. under no load

**Differential Input Voltage:**  $\pm 5$  VDC max.

**Mark Condition:**  $\leq -0.2$  VDC

**Space Condition:**  $\geq +0.2$  VDC

**RS485 Drive Capability:** Up to 32 RS485 receivers connected in parallel.

**RS485 Drive Disable Time:** 4 msec. max.

**3. MAXIMUM CABLE LENGTH:**

**RS-232:** 50 feet

**RS485:** 4000 feet

**4. BAUD RATE:** 9600 min., 19200 max.

### Ordering Information

MODEL NO.	DESCRIPTION	PART NUMBER
ICM4	RS232/RS485 Converter Module	ICM40030

## MODEL GCM232 - SERIAL CONVERTER MODULE



- ALLOWS COMMUNICATIONS BETWEEN RS-232 CONTROL EQUIPMENT AND RLC PRODUCTS WITH 20 mA SERIAL COMMUNICATIONS OPTION
- ISOLATED 20 mA SERIAL COMMUNICATIONS
- FULLY ENCLOSED SCREW-TOGETHER DURABLE PLASTIC CASE



EMC COMPLIANT



COMMUNICATIONS CAPABILITY

Click Icon For User Bulletin



FAX/WEB  
DOC # 12008

### Product Features

The GCM232 Serial Converter Module provides the capability of interfacing Red Lion Controls products with 20 mA current loop serial communications option to most equipment with RS-232 communications. The isolated 20 mA current loop connections in the GCM232 allows multiple modules to be wired into the serial loop. Data format of the RS-232 equipment must be the same as the Red Lion Controls product (*Reference the serial communications section of the appropriate manual for more details*).

An external +12 VDC power source is required to power the GCM232 module. Some Red Lion Controls products have a +12 VDC output which can be used (*Note: Reference appropriate manual to ensure +12 volt output has enough current capability*). The external power source and isolated 20 mA serial communications loop connections are made via a 6 position terminal block located inside the module. A 680Ω current limiting resistor is provided to obtain the source current for the Serial Current Loop. Connections for the RS-232 are made via a 25-pin female D-type connector.

### General Specifications

- POWER:** + 9 to 28 VDC @ 30 mA max.  
Power supplies must be Class 2 or SELV rated.
- ENVIRONMENTAL CONDITIONS:**  
**Operating Temperature:** 0 to 50°C  
**Storage Temperature:** -40 to 80°C  
**Operating and Storage Humidity:** 85% max. (non-condensing) from 0°C to 50°C.  
**Altitude:** Up to 2000 meters
- CERTIFICATIONS AND COMPLIANCES:**  
**SAFETY**  
EN 61010-1, IEC 1010-1

#### ELECTROMAGNETIC COMPATIBILITY

Immunity to EN 50082-2  
Emissions to EN 50081-2

- DIMENSIONS:**  
0.99" (25.2 mm) H x 2.10" (53.4 mm) W x 4.32" (109.8 mm) L
- Shielded cable must be used, connect shield drain wire to earth ground.

### Input/Output Communications

- RS-232 VOLTAGES:**  
**Receive Data Pin 2:** ± 30 VDC<sub>max</sub>, mark condition ≤ 0.8 VDC  
space condition ≥ 2.4 VDC.  
**Transmit Data Pin 3:** mark condition = -10 VDC (*typ*).  
space condition = +10 VDC (*typ*).
- 20mA CURRENT LOOP:**  
**SO - Output Transistor Rating:** V<sub>max</sub> = 25 VDC,  
V<sub>sat</sub> = 1 VDC<sub>max</sub> @ 20 mA.

**SI - Input Diode Rating:** V<sub>F</sub> = 1.25 VDC<sub>typ</sub>, 1.5 VDC<sub>max</sub> @ 20 mA.  
(*Note: Reverse polarity protection at SI diode*)

- MAXIMUM CABLE LENGTH:**  
**RS-232 cable:** 50 Ft.  
**20 mA current loop:** 4000 Ft.
- BAUD RATE:** 9600 max.

### Ordering Information

MODEL NO.	DESCRIPTION	PART NUMBER
GCM232	Serial Converter Module RS-232	GCM23201

## MODEL GCM422 - SERIAL CONVERTER MODULE

- ALLOWS COMMUNICATIONS BETWEEN RS422 CONTROL EQUIPMENT AND RLC PRODUCTS WITH 20 mA SERIAL COMMUNICATIONS OPTION
- TRANSMIT DISABLE ALLOWS OPERATION ON A TWO-WIRE BUS FOR RS485 COMPATIBILITY
- ISOLATED 20 mA SERIAL COMMUNICATIONS
- FULLY ENCLOSED SCREW TOGETHER DURABLE PLASTIC CASE



EMC COMPLIANT



COMMUNICATIONS CAPABILITY

### Product Features

The GCM422 Serial Converter Module provides the capability of interfacing Red Lion Controls products, with 20 mA current loop serial communications option, to any equipment with RS-422 communications. The isolated 20 mA current loop connections in the GCM422 allow multiple modules to be wired into the serial loop. Data format of the RS-422 equipment must be the same as the Red Lion Controls product (Reference the serial communications section of the appropriate manual for more details). The GCM422 module can be made to interface with RS-485 equipment by repositioning an internal jumper (which is a removable plug type arrangement). (The user must supply a method of electrically selecting the transmit disable input.)

An external power source is required to power the GCM422 module. Some Red Lion Controls products have a +12 VDC output which can be used. (Note: Reference appropriate manual to ensure +12 VDC output has enough current capability.) The external power source and isolated 20 mA serial communications loop connections are made via a 6 position terminal block located inside the module. A 680Ω current limiting resistor is provided to obtain the source current for the Serial Current Loop. Connections for the RS-422 or RS-485 are made via a 25 pin female D-type connector.



FAX/WEB  
DOC # 12009

Click Icon For  
User Bulletin

### General Specifications

- POWER:** +9 to 26 VDC @ 50 mA max. Power supplies must be Class 2 or SELV rated.
- ENVIRONMENTAL CONDITIONS:**  
**Operating Temperature:** 0 to 50°C  
**Storage Temperature:** -40 to 80°C  
**Operating and Storage Humidity:** 85% max. (non-condensing) from 0°C to 50°C.  
**Altitude:** Up to 2000 meters
- CERTIFICATIONS AND COMPLIANCES:**  
**SAFETY**  
 EN 61010-1, IEC 1010-1  
**ELECTROMAGNETIC COMPATIBILITY**  
 Immunity to EN 50082-2  
 Emissions to EN 50081-2
- DIMENSIONS:**  
 0.99" (25.2 mm) H x 2.10" (53.4 mm) W x 4.32" (109.8 mm) L
- Shielded cable must be used, connect shield drain wire to earth ground.

### Input/Output Communications

- RS-422 VOLTAGES:**  
**Differential output voltage (pins 2 & 14):** ±5 VDC<sub>max</sub> under no load condition.  
**Differential input voltage (pins 3 & 16):** ±5 VDC<sub>max</sub>.  
**mark condition** = ≤ -0.2 VDC  
**space condition** = ≥ 0.2 VDC  
**Common mode input voltage:** -7 VDC to +12 VDC.
- RS-485 TRANSMIT DISABLE INPUT (Pin 4):**  
 Active low V<sub>IL</sub> = 0.8 VDC<sub>max</sub>.  
 Internally pulled up to +5 VDC through 3.3 KΩ resistor.
- RS-422 DRIVE CAPACITY:** Up to 32 RS-422 receivers connected in parallel.  
 (Note: RS-485 Specifications are the same as RS-422)
- 20 mA CURRENT LOOP:**  
**SO - Output Transistor Rating:** V<sub>max</sub> = 25 VDC,  
 V<sub>sat</sub> = 1 VDC<sub>max</sub> @ 20 mA.  
**SI - Input Diode Rating:** V<sub>F</sub> = 1.25 VDC<sub>typ</sub>, 1.5 VDC<sub>max</sub> @ 20 mA.  
 (Note: Reverse polarity protection at SI diode)
- MAXIMUM CABLE LENGTH:**  
**RS-422 or RS-485 cable:** 4000 Ft.  
**20 mA current loop:** 4000 Ft.
- BAUD RATE:** 9600 Baud max.

### Ordering Information

MODEL NO.	DESCRIPTION	PART NUMBER
GCM422	Serial Converter Module RS422	GCM42201

## MODEL GWDN - DEVICENET™ GATEWAY MODULE



- ALLOWS COMMUNICATIONS BETWEEN DEVICENET™ CONTROL EQUIPMENT AND PRODUCTS WITH RS485 SERIAL COMMUNICATIONS, INCLUDING MODBUS
- HALF DUPLEX (RS485) AND FULL DUPLEX (RS422)
- LED INDICATION FOR RXD, TXD, and DEVICENET™ STATUS
- UNIVERSAL MOUNTING FOOT FOR DIN RAIL INSTALLATION



Click Icon For User Bulletin



FAX/WEB  
DOC # 12016

### Product Features

The GWDN DeviceNet™ Gateway Module provides the capability of interfacing equipment with RS485/422 serial communications to equipment with DeviceNet™ communications capability. Communications is accomplished by embedding ASCII data within explicit messages.

Four wire RS-422 and two wire RS-485 are supported, as well as standard DeviceNet™ communications capability.

A DIP switch, located on one side of the unit, and accessible from the outside, provides the means to set the DeviceNet™ MacId and the DeviceNet™ baud rate.

There are four LED's that can be viewed from the front of the converter module. Two green LED's indicate the receive and transmission of data on the RS485/422 side. A green and a red LED provide a visual indication of the status of the DeviceNet™ communications.

All power to the unit is provided via the DeviceNet™ cable. All connections to the unit are made via a 12 position removable terminal block located on the front of the module.

The unit is equipped with a universal mounting foot for attachment to standard DIN style mounting rails, including top hat profile rail according to EN 50 022 -35x7.5 and -35x15, and G profile rail according to EN 50 035 - G32.

### DIMENSIONS "In inches (mm)"

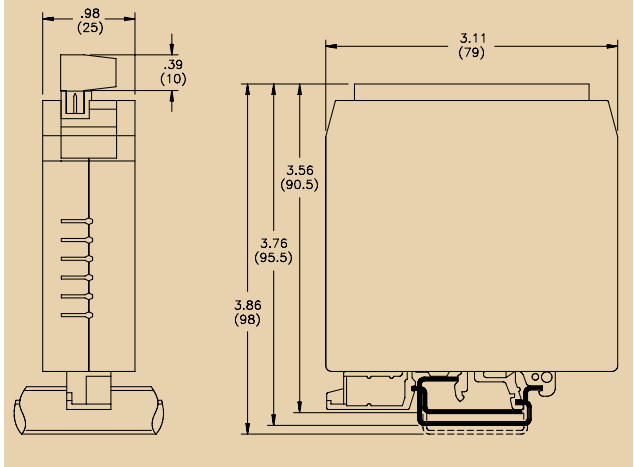

### General Specifications

- POWER:** Power is supplied by the DeviceNet™ cable. Consult DeviceNet™ specification Volumes I and II.
- ENVIRONMENTAL CONDITIONS:**  
**Operating Temperature Range:** 0 to 50°C.  
**Storage Temperature:** -40 to + 75°C  
**Operating and Storage Humidity:** 85% max.relative humidity (non-condensing) from 0 to 50°C  
**Altitude:** Up to 2000 meters
- CERTIFICATIONS AND COMPLIANCES:**  
**SAFETY**  
 EN 61010-1, IEC 1010-1  
**ELECTROMAGNETIC COMPATIBILITY**  
 Immunity to EN 50082-2  
 Emissions to EN 50081-2
- CONSTRUCTION:** Case body is green, high impact plastic. Installation Category I, Pollution Degree 2.
- MOUNTING:** Standard DIN rail top hat (T) profile rail according to EN50022 -35 X 7.5 and -35 X 15
- WEIGHT:** 3.5 oz. (99.22 g.)
- POWER SUPPLY**  
**Source:** Supplied by DeviceNet™ bus.  
 The bus does not power the host.  
**Voltage:** 11 to 25 VDC.  
**Current:**  
**Nominal:** 18 mA at 25 VDC.  
**Inrush:** Test documentation available upon request.

## MODEL GWDN - DEVICENET™ GATEWAY MODULE

### Input/Output Communications

#### 1. RS485 VOLTAGES:

**Differential Output Voltage:** ± 5 VDC max. under no load

**Differential Input Voltage:** ± 5 VDC max.

**Mark Condition:** ≤ -0.2 VDC

**Space Condition:** ≥ +0.2 VDC

**RS485 Drive Capability:** Up to 32 RS485 receivers connected in parallel.

#### 2. MAXIMUM CABLE LENGTH:

**RS485:** 4000 feet

**DeviceNet:** Check DeviceNet™ specification Volumes I and II.

#### 3. RS485 BAUD RATE:

300 min., 19200 max.

#### 4. NETWORK SPECIFICS

**Compatibility:** Group 2 Server Only, not UCMM capable.

**Baud Rates:** 125 Kbaud, 250 Kbaud, and 500 Kbaud.

**Bus Interface:** Phillips 82C250 or equivalent with MIS wiring protection per DeviceNet™ Volume 1 Section 10.2.2.

**Node Isolation:** Bus powered, isolated node.

**Bus Connection:** \*

1 V+

2 V-

3 CAN\_L

4 CAN\_H

\* Shield: Refer to Appendix A, DeviceNet™ Physical Layer Schematics section of Volume I, of the ODVA Specifications Manual.

#### 5. INSTALLATION INFORMATION

**Initial Values (Factory Settings):**

**Baud rate:** 125 KBaud

**MacID:** 63

### Ordering Information

MODEL NO.	DESCRIPTION	PART NUMBER
GWDN	DeviceNet/RS485 Converter Module	GWDN0000
CBDN	DeviceNet Mini Receptacle Cable	CBDN1AD6
	DeviceNet Micro Receptacle Cable	CBDN2AD6

## MODEL PSDR6 - SIGNAL CONDITIONER 650 mA POWER SUPPLY



UL RECOGNIZED  
USA



UL RECOGNIZED  
CANADA



EMC  
COMPLIANT

Click Icon For  
User Bulletin



FAX/WEB  
DOC# 06002

### Product Features

The compact PSDR power supplies are an industrial input voltage supplies with primary switched-mode regulator technology. They feature low output ripple and tight ( $\pm 3\%$ ) nominal voltage tolerance. The output is electronically protected against overloads and short circuits.

The modules snap onto standard 35 mm flat DIN rails, and use removable terminal blocks for easy wiring.

### DIMENSIONS "In Inches (mm)"

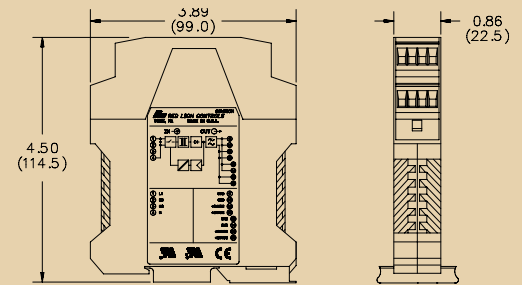

### General Specifications

- ISOLATION VOLTAGE:**  
Input to Output: 3.75 kV
- OPERATING TEMPERATURE RANGE:** -20 to 60°C
- CERTIFICATIONS AND COMPLIANCES:**  
**SAFETY**  
EN 61010-1, IEC 1010-1  
UL Recognized Component, File #E172153(M)  
Recognized to U.S. and Canadian requirements under the Component Recognition Program of Underwriters Laboratories, Inc.

#### ELECTROMAGNETIC COMPATIBILITY

- Immunity to EN 50082-2
  - Emissions to EN 50081-2
- CONSTRUCTION:** Case body is green, high impact plastic. Protection Class II.
  - CONNECTIONS:** 24 to 14 AWG max.
  - MOUNTING:** Standard DIN rail top hat (T) profile rail according to EN50022 -35 X 7.5 and -35 X 15
  - WEIGHT:** 4.93 oz (140 g)

### Input Specifications

- POWER REQUIREMENTS:**  
120 VAC, 0.4A  $\pm 10\%$  or 100 to 200 VDC  
220 VAC, 0.2A  $\pm 10\%$  or 200 to 375 VDC
- FREQUENCY:** 47 to 63 Hz

### Output Specifications

- POWER OUTPUT:** 24 VDC  $\pm 3\%$  @ 650 mA max.

### Ordering Information

MODEL NO.	INPUT	OUTPUT	PART NUMBER
PSDR6	120 VAC	24 VDC	PSDR6200
	220 VAC	24 VDC	PSDR6210

## MODEL PSDR12 - SIGNAL CONDITIONER 100 mA POWER SUPPLY

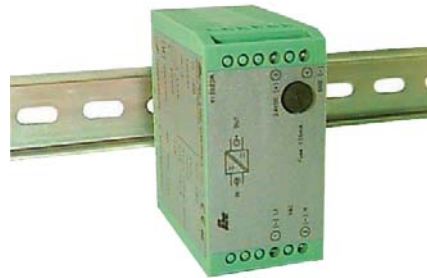

EMC  
COMPLIANT



UL RECOGNIZED  
USA

### Product Features

PSDR power supplies are compact, linear and highly regulated. Well suited for use with all signal conditioning products. They feature low output ripple and tight ( $\pm 4\%$ ) nominal voltage tolerance.

Single isolated output power supply versions are available for galvanic separation. The power supply outputs are fused. The PSDR features a universal foot for easy installation via universal DIN rail mounting.

### DIMENSIONS "In Inches (mm)"

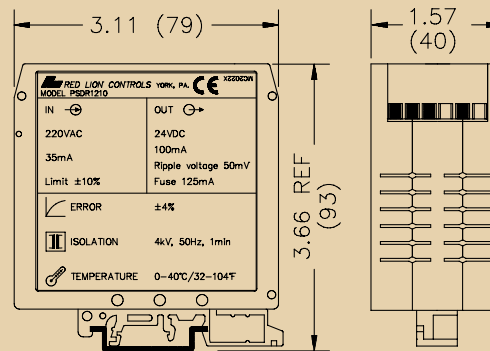

Click Icon For  
User Bulletin

FAX/WEB  
DOC# 10012

### General Specifications

- FUSE:** Fine fuse 125 mA (5 x 20 mm), medium- blow.
- ISOLATION VOLTAGE:**  
Input to Output: 4 kV, 50 Hz, 1 minute
- ACCURACY:**  $\leq 0.1\%$  of full scale
- OPERATING TEMPERATURE RANGE:** 0 to 40°C
- CONSTRUCTION:** Case body is green, high impact plastic.
- CONNECTIONS:** 14 AWG max.
- MOUNTING:** Standard DIN style rail, including top hat (T) profile rail according to EN50022 - 35 x 7.5 and 35 x 15, and G profile rail according to EN50035 - G32.
- WEIGHT:** 10.3 oz (292.11 g)

### Input Specifications

- POWER REQUIREMENTS:**  
120 VAC, 70 mA  $\pm 10\%$   
220 VAC, 35 mA  $\pm 10\%$

### Output Specifications

- POWER OUTPUT:** 24 VDC  $\pm 4\%$  @ 100 mA max.

### Ordering Information

MODEL NO.	INPUT	OUTPUT	PART NUMBER
PSDR12	220 VAC	24 VDC	PSDR1210*
	120 VAC	24 VDC	PSDR1200

\* The 220 VAC Version is not UL Recognized



## MODEL PSDR13 - SIGNAL CONDITIONER 1 A POWER SUPPLY



UL RECOGNIZED  
USA



EMC  
COMPLIANT

Click Icon For  
User Bulletin



FAX/WEB  
DOC# 10013

### Product Features

PSDR power supplies are compact, linear and highly regulated. They are well suited for use with all signal conditioning products. They feature low output ripple and tight ( $\pm 1\%$ ) nominal voltage tolerance.

The PSDR1300 power supply is fused on both the input and output with 1 A ( $5 \times 20$  mm) fuses. Slow-blow fuses are used on the input to accommodate start-up current, and fast-blow fuses on the output for fast response to overloads to ensure safe operation and limit damage to loads if a fault would occur. An LED on the output provides visual indication of power and fuse condition.

Preferred mounting is horizontal (*horizontal rail orientation on a vertical panel*) for optimum convection airflow through the cooling fins and ventilation slots in the case.

Installation is simplified over open frame supplies: there are no holes to drill or brackets to mount. The power supply is simply snapped onto a standard DIN rail.

### DIMENSIONS "In Inches (mm)"

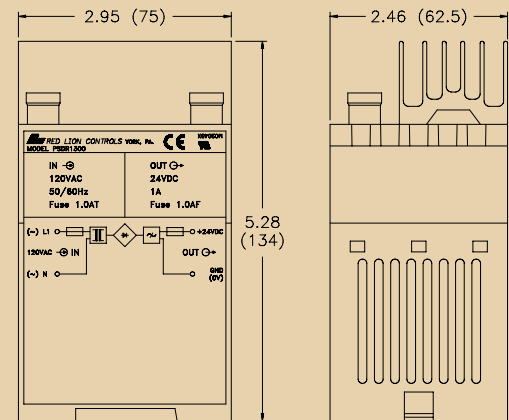

### General Specifications

- FUSE:**  
**Input Fuse:** Fine fuse 1 A ( $5 \times 20$  mm), slow blow.  
**Output Fuse:** 1 A ( $5 \times 20$  mm) fast blow.
- ISOLATION VOLTAGE:**  
**Input to Output:** 4 kV, 50 Hz, 1 minute
- OPERATING TEMPERATURE RANGE:**  $0^{\circ}$  to  $60^{\circ}$ C
- CONSTRUCTION:** Case body is green, high impact plastic.
- SPACING BETWEEN SUPPLIES:**  $>10$  mm / 0.4 inches
- CONNECTIONS:** 14 AWG max.
- MOUNTING:** Standard DIN Top hat (T) profile rail according to EN50022  $-35 \times 7.5$  and  $-35 \times 15$ .
- WEIGHT:** 2.62 lb (1.19 Kg)

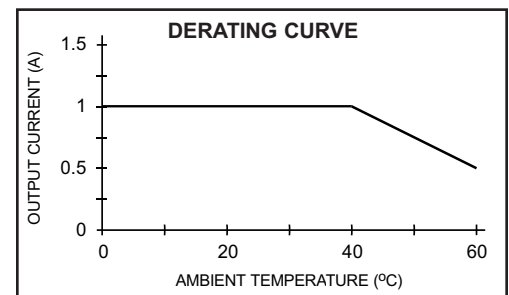

## MODEL PSDR13 - SIGNAL CONDITIONER 1 A POWER SUPPLY

### Input Specifications

1. **INPUT POWER REQUIREMENTS:** 120 VAC, +6/ -10%  
Max. Input Power: 55 VA

### Output Specifications

1. **POWER OUTPUT:** 24 VDC  $\pm 1\%$  @ 1 A DC max.  
Ripple: <20 mV pk-pk

### Ordering Information

MODEL NO.	INPUT	OUTPUT	PART NUMBER
PSDR13	120 VAC	24 VDC	PSDR1300

## MODEL RS - DIN RAIL RELAY SYSTEM

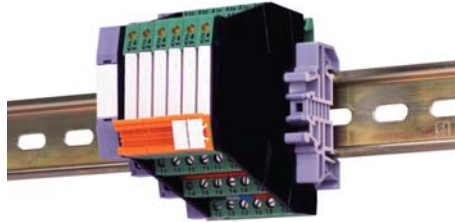

- TERMINAL BLOCKS WITH BUILT-IN RELAY OUTPUTS
- SLIM DESIGN SAVES DIN RAIL SPACE
- REPLACEABLE RELAY SAVES DOWNTIME
- JUMPERS SAVE WIRING TIME

Click Icon For User Bulletin



FAX/WEB  
DOC # 10018

### Product Features

The RS Relay System provides a compact, modular means of adding relay outputs to any transistor output device. The RSRLYB Relay Block serves as the base for a miniature, 24 volt

coil relay, capable of switching up to 250 VAC at 6 Amps. Accessories, such as Jumpers, Buss Blocks, and Relay Markers are available to save installation time and money.

### RSRLYB - RELAY BLOCK

The RS Relay System is built around the Relay Block. The Relay Block is a 6.2 mm wide terminal block that serves as the base for the miniature plug-in relay (included). The relay has a 24 VDC coil, and its SPDT output can switch loads up to 250 VAC at 6 Amps. With its plug-in design, the relay can be replaced in seconds. The Block has a built-in suppression circuit to reduce EMC interference. Other features include an input LED, and reverse polarity protection. The RSRLYB00 is shipped in packages of 5 pieces, with the relay installed.

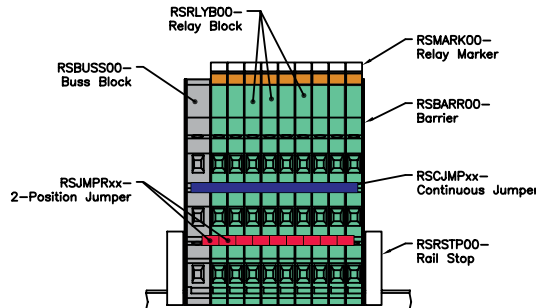

#### DIMENSIONS "In Inches (mm)"

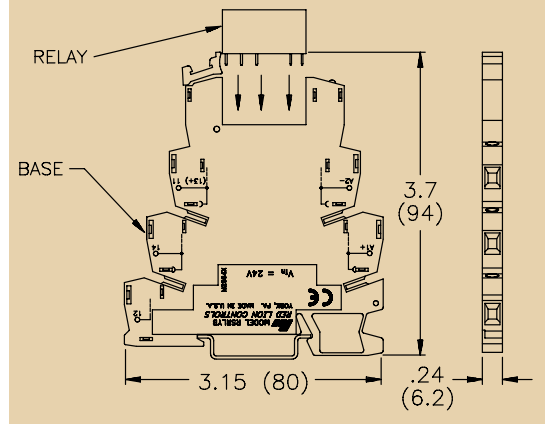

### General Specifications

1. **INPUT TO OUTPUT ISOLATION:** 4 kV, 50 Hz., 1 minute
2. **AMBIENT TEMPERATURE RANGE:** -20 to 60°C (-4 to 140°F)
3. **NOMINAL OPERATING MODE:** 100% Duty Cycle
4. **INFLAMMABILITY CLASS:** VO according To UL 94
5. **CONSTRUCTION:** Case body is green, Polyimide PA non-reinforced
6. **CONNECTIONS:** 14 AWG max. Torque 4-6 in-lb.
7. **MOUNTING:** Standard DIN Top Hat (T) profile rail according to EN50022 -35 x 7.5 and -35 x 15.
8. **WEIGHT:** 0.073 lb. (33.1 g)

### Input Specifications

1. **NOMINAL INPUT VOLTAGE:** 24 VDC
2. **TYPICAL INPUT CURRENT at 24 VDC:** 9 mA
3. **MAX. INRUSH CURRENT:** 30 A

### Output Specifications

1. **TYPICAL OPERATE TIME:** 4 msec
2. **TYPICAL RELEASE TIME:** 8 msec
3. **CONTACT TYPE:** SPDT (Form C)
4. **CONTACT MATERIAL:** AgSnO
5. **MAX. CONTACT VOLTAGE:** 250 V AC/DC
6. **MIN. CONTACT VOLTAGE:** 12 V AC/DC
7. **LIMITING CONTINUOUS CURRENT:** 6 A
8. **MIN. SWITCHING CURRENT:** 10 mA
9. **MAX. POWER RATING (RESISTIVE LOAD):** 140 W
10. **MIN. SWITCHING POWER:** 120 mW
11. **MECHANICAL LIFE:** 20 million cycles

### MODEL RS - DIN RAIL RELAY SYSTEM

#### RSJMPR - 2-POSITION JUMPER

The RSJMPR Jumper can be used to bridge connections between adjacent Relay Blocks. This avoids the tedious task of wire-jumping signals such as commons or neutrals together. The maximum current capability of the RSJMPR is 6 A. The RSJMPR is available in three different colors, and is shipped in packages of 20 pieces.

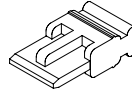

#### General Specifications

1. **MAX. CURRENT:** 6 A
2. **LENGTH:** 0.24" (6 mm)
3. **COLOR:** Available in Red, Blue, and Gray

#### RSCJMP - CONTINUOUS JUMPER

The RSCJMP can be used to bridge up to 80 adjacent Relay Blocks with total currents as high as 32 A. For currents above 6 A, the Buss Block must be used as the starting point. This cut-to-length jumper is available in three colors, and is shipped in packages of 2 pieces.

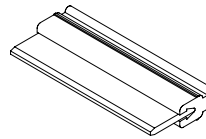

#### General Specifications

1. **MAX. CURRENT:** 32 A
2. **LENGTH:** 19.7" (500 mm)
3. **COLOR:** Available in Red, Blue, and Gray

#### RSBUSS - BUSS BLOCK

The 9 mm wide Buss Block is the same shape as the RSRLYB Relay Block. It can be used as a starting point for the continuous jumper in applications requiring up to 32 A. In applications that require less than 6 A, the starting point for the jumper(s) can take place at one of the Relay Blocks.

#### General Specifications

1. **MAX. CURRENT:** 32 A
2. **MAX. VOLTAGE:** 250 V
3. **CONSTRUCTION:** Case body is gray, Polyimide PA non-reinforced
4. **CONNECTIONS:** 10 AWG max. Torque 4-6 in-lb.
5. **WEIGHT:** 0.077 lb. (34.9 g)

## MODEL RS -DIN RAIL RELAY SYSTEM

### RSBARR - BARRIER

The Barrier is always required at the start and end of a Relay System to provide protective separation according to VDC 0106-101. The Barrier should also be used to isolate adjacent Relay Blocks with voltage potentials greater than 250 V. The RSBARR is equipped with prescored breakout points at the bridging positions so that individual bridges can pass through if needed. The RSBARR00 is shipped in packages of 2 pieces.

### General Specifications

1. **COLOR:** Black

### RSMARK - RELAY MARKERS

The RSMARK00 Relay Markers can be used to label the Relay Blocks. After labeling or writing on the Marker, it is snapped onto the engagement lever of the Relay Block, providing a visual means of identification. The RSMARK00 is shipped in packages of 100 pieces.

### General Specifications

1. **COLOR:** White

### Ordering Information

MODEL NO.	DESCRIPTION	QUANTITY/PACKAGE	PART NUMBER
RSRLYB	Relay Block	5	RSRLYB00
RSBUSS	Buss Block	1	RSBUSS00
RSBARR	Barrier	2	RSBARR00
RSRSTP	Rail Stop	2	RSRSTP00
RSJMPR	2-Position Jumper Red	20	RSJMPR10
	2-Position Jumper Blue	20	RSJMPR20
	2-Position Jumper Gray	20	RSJMPR30
RSCJMP	Continuous Jumper Red	2	RSCJMP10
	Continuous Jumper Blue	2	RSCJMP20
	Continuous Jumper Gray	2	RSCJMP30
RSMARK	Relay Marker	100	RSMARK00
RSRLY1	Replacement Relay	5	RSRLY100

## MODEL RLY6 - SINGLE PHASE DIN RAIL MOUNT SOLID STATE RELAY

- INTEGRATED HEAT SINK
- OPTICALLY ISOLATED
- SOLID STATE SWITCHING
- 25 A SINGLE PHASE OUTPUT RATING
- 48 TO 660 VAC SWITCHING
- 4 TO 28 VDC CONTROL SIGNAL
- ZERO VOLTAGE TURN-ON
- MOUNTS ON DIN RAIL OR DIRECTLY TO PANEL
- 4000 VOLT ISOLATION
- BUILT-IN SNUBBER
- LED "ON" INDICATOR
- CAGE CLAMP TERMINATIONS



UL RECOGNIZED  
USA



CSA  
CERTIFIED



EMC  
COMPLIANT

### Product Features

The RLY60000 is a solid state relay that switches load currents up to 25 A. The unit features a zero voltage turn-on detector to minimize radiated RFI when switching. An internal snubber guards against false triggering of the output related to high dv/dt applications. A low level DC control signal of 4 to 28 VDC is all that is needed for the switching operation. This unit, highlighted by the inverse-parallel SCR output, provides a greatly increased operational life over a mechanical relay by avoiding the usual relay contact problems such as: arcing, bouncing, and mechanical failure.

The RLY60000 can be directly controlled by logic/SSR drive output or sourcing output of Red Lion Controls products.

### DIMENSIONS "In Inches (mm)"

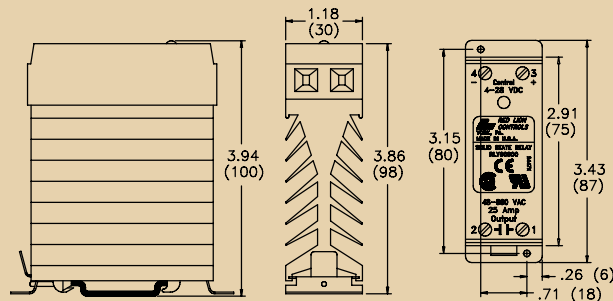

Click Icon For  
User Bulletin

FAX/WEB  
DOC # 12021

### General Specifications

1. ISOLATION (INPUT TO OUTPUT TO BASE): 4000  $V_{RMS}$
2. CAPACITANCE INPUT TO OUTPUT: 3 pf
3. OPERATING TEMPERATURE RANGE: -40°C to +100°C

### Input Specifications

1. CONTROL VOLTAGE RANGE: 4 to 28 VDC
2. TURN-ON VOLTAGE (MIN.): 4 VDC
3. TURN-OFF VOLTAGE (MAX.): 1 VDC
4. REVERSE VOLTAGE PROTECTION: -75 VDC
5. INPUT CURRENT (MAX.): 15 mA

## MODEL RLY6 - SINGLE PHASE DIN RAIL MOUNT SOLID STATE RELAY

### Output Specifications

1. **OPERATING VOLTAGE RANGE:** 48 to 660 VAC
2. **OPERATING FREQUENCY RANGE:** 47 to 63 Hz
3. **MAXIMUM CONTINUOUS LOAD CURRENT:** 25 A<sub>RMS</sub> (See Safe Operating Conditions)
4. **SURGE CURRENT:**  
 Non-Repetitive 1 Cycle: 250 A<sub>PEAK</sub>  
 Non-Repetitive 1 Second: 100 A<sub>PEAK</sub>
5. **MIN. LOAD CURRENT:** 50 mA
6. **LEAKAGE CURRENT @ V<sub>OUT</sub> (MAX.):** 8 mA
7. **OVER VOLTAGE RATING:** 1200 PIV
8. **VOLTAGE DROP @ I<sub>OUT</sub>:** 1.5 VAC
9. **POWER DISSIPATION AT FULL LOAD:** 37.5 Watts
10. **I<sup>2</sup>T FUSING:** 1035 A<sup>2</sup>S  
 (For Fusing Purposes, T = 8.3 msec.)
11. **Dv/Dt @ V<sub>OUT</sub> (Max.):** 500 V/μsec

### SAFE OPERATING CONDITIONS

The relay must always operate within the "Safe Operating Area" of the Derating Curve Figure. Operations outside the Safe Operating Area will shorten the life of, or cause permanent damage to, the relay. The ambient temperature should be measured 1" (25 mm) below the relay (when mounted to a vertical surface) and with all of the associated equipment operating.

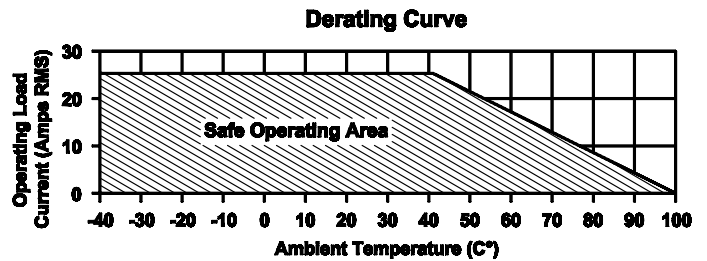

### Ordering Information

MODEL NO.	DESCRIPTION	PART NUMBERS
RLY6	Single Phase Din Rail Mount Solid State Relay	RLY60000

## MODEL RLY7 - THREE PHASE DIN RAIL MOUNT SOLID STATE RELAY

- INTEGRATED HEAT SINK
- OPTICALLY ISOLATED
- SOLID STATE SWITCHING
- 30 A THREE PHASE OUTPUT RATING
- 48 TO 660 VAC SWITCHING
- 4 TO 28 VDC CONTROL SIGNAL
- ZERO VOLTAGE TURN-ON
- MOUNTS ON DIN RAIL OR DIRECTLY TO PANEL
- 4000 VOLT ISOLATION
- BUILT-IN SNUBBER
- LED "ON" INDICATOR
- CAGE CLAMP TERMINATIONS



UL RECOGNIZED  
USA



CSA  
CERTIFIED



EMC  
COMPLIANT

### Product Features

The RLY70000 is a three phase solid state relay that switches load currents up to 30 A. The unit features a zero voltage turn-on detector to minimize radiated RFI when switching. An internal snubber guards against false triggering of the output related to high dv/dt applications. A low level DC control signal of 4 to 28 VDC is all that is needed for the switching operation. This unit,

highlighted by the inverse-parallel SCR output, provides a greatly increased operational life over a mechanical relay by avoiding the usual relay contact problems such as: arcing, bouncing, and mechanical failure.

The RLY7000 can be directly controlled by logic/SSR drive output or sourcing output of Red Lion Controls products.



Click Icon For  
User Bulletin

FAX/WEB  
DOC # 12022

### DIMENSIONS "In Inches (mm)"

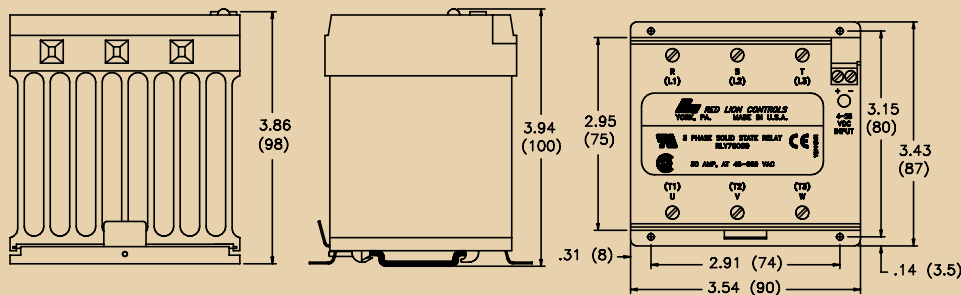

### General Specifications

1. ISOLATION (INPUT TO OUTPUT TO BASE): 4000  $V_{RMS}$
2. CAPACITANCE INPUT TO OUTPUT: 3 pf
3. OPERATING TEMPERATURE RANGE: -40°C to +100°C

### Input Specifications

1. CONTROL VOLTAGE RANGE: 4 to 28 VDC
2. TURN-ON VOLTAGE (MIN.): 4 VDC
3. TURN-OFF VOLTAGE (MAX.): 1 VDC
4. REVERSE VOLTAGE PROTECTION: -75 VDC
5. INPUT CURRENT (MAX.): 45 mA



## MODEL RLY7 - THREE PHASE DIN RAIL MOUNT SOLID STATE RELAY

### Output Specifications

1. **OPERATING VOLTAGE RANGE:** 48 to 660 VAC
2. **OPERATING FREQUENCY RANGE:** 47 to 63 Hz
3. **MAXIMUM CONTINUOUS LOAD CURRENT:** 30 A<sub>RMS</sub> /phase (See Safe Operating Conditions)
4. **SURGE CURRENT:**  
 Non-Repetitive 1 Cycle: 250 A<sub>PEAK</sub>  
 Non-Repetitive 1 Second: 100 A<sub>PEAK</sub>
5. **MIN. LOAD CURRENT:** 50 mA
6. **LEAKAGE CURRENT @ V<sub>OUT</sub> (Max.):** 8 mA
7. **OVER VOLTAGE RATING:** 1200 PIV
8. **VOLTAGE DROP @ I<sub>OUT</sub>:** 1.5 VAC
9. **POWER DISSIPATION AT FULL LOAD:** 130 Watts
10. **I<sup>2</sup>T FUSING:** 1035 A<sup>2</sup>S  
 (For Fusing Purposes, T = 8.3 msec.)
11. **Dv/Dt @ V<sub>OUT</sub> (Max.):** 500 V/μsec

### SAFE OPERATING CONDITIONS

The relay must always operate within the "Safe Operating Area" of the Derating Curve Figure. Operations outside the Safe Operating Area will shorten the life of, or cause permanent damage to, the relay. The ambient temperature should be measured 1" (25 mm) below the relay (when mounted to a vertical surface) and with all of the associated equipment operating.

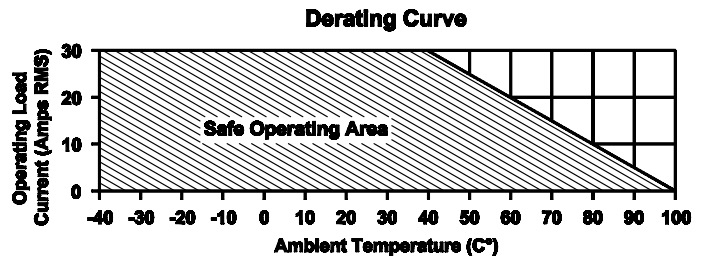

### Ordering Information

MODEL NO.	DESCRIPTION	PART NUMBERS
RLY7	Three Phase Din Rail Mount Solid State Relay	RLY70000

## MODEL AVMR - RELAY TERMINAL BLOCKS

- 2 LAYER DOUBLE CONTACT SWITCHES FROM 1 mA TO 3 A CONTINUOUS CURRENT
- ISOLATION BETWEEN INPUT AND OUTPUT OF 2 KV RMS
- INPUT VOLTAGE OF 24 VAC/DC
- LED TO INDICATE THE SWITCHING STATUS
- DAMPING AND POLARITY PROTECTION FUNCTIONS



UL RECOGNIZED  
USA

### Product Features

RLC relay terminal blocks are only 6.2 mm wide, but provide a complete relay interface.

The relay terminal blocks are equipped with the newest development in electromechanical miniature relays. Two versions are available for opposing signal directions. The input and output relays can be differentiated by the LEDs that are arranged on the respective side of the coil.



[Click Icon For User Bulletin](#)

FAX/WEB  
DOC# 10004

### DIMENSIONS "In Inches (mm)"

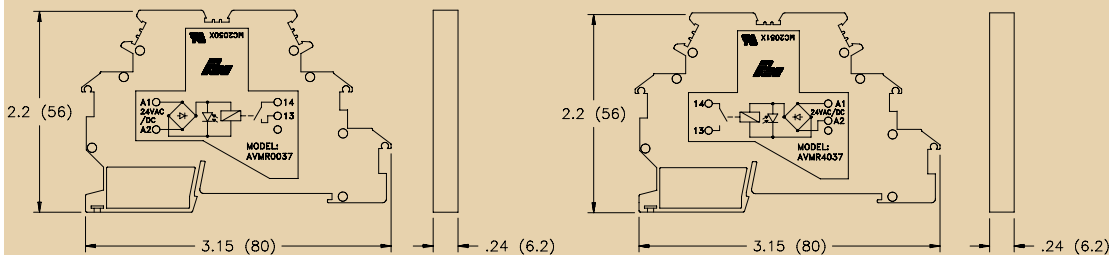

### General Specifications

1. **ISOLATION VOLTAGE:**  
Winding to Contact: 2 kV, 50 Hz, 1 minute
2. **AMBIENT TEMPERATURE RANGE:** -20 to +50°C
3. **NOMINAL OPERATING MODE:** 100% duty cycle
4. **CONSTRUCTION:** Case body is green, high impact plastic.
5. **CONNECTIONS:** 14 AWG max., Torque 5-7 in-lb.
6. **MOUNTING:** Standard DIN Top hat (T) profile rail according to EN50022 - 35 x 7.5 and -35 x 15.
7. **WEIGHT:** 0.704 oz. (19.96 g)

### Input Specifications

1. **COIL SIDE:**  
Input Nominal Voltage: 24 VAC/DC  
Permissible Range of Nominal Voltage: 0.8 to 1.1  
Typ. Input Current with Nominal Voltage: 6.5 mA  
Typ. Operate Time with Nominal Voltage: 5 msec  
Typ Release Time with Nominal Voltage: 15 msec

## MODEL AVMR - RELAY TERMINAL BLOCKS

### Output Specifications

1. **CONTACT SIDE:**  
**Contact Type:** Double Contact, Form A  
**Contact Material:** AgNi, 5mm hard gold plated  
**Max. Contact Voltage:** 250 VAC/ 30 VDC  
**Min. Contact Voltage:** 5 V  
**Max. Inrush Current:** 5 A  
**Limiting Continuous Current:** 3 A  
**Min. Switching Current:** 1 mA  
**Max. Power Rating:** 72 W
2. **MECHANICAL LIFE:** 20 million cycles

### Ordering Information

MODEL NO.	DESCRIPTION	PART NUMBER
AVMR	INPUT	AVMR0037
	OUTPUT	AVMR4037

