



Product Change Notification

Date Issued :	February 29, 2024	PCN Number :	514934
Reason for Change :	Capacity change or tool replacement		
Description of Change :	This notification is to inform you about set of tooling is being added to meet the current and future demands of 350211360. There will be no changes in fit, form or function from additional tooling when compared to the existing tooling.		
Reason for Short Notice :	Special Request		
Assessment of Change :	First Article Inspection		
Planned Implementation Date :	May 15, 2024		
Customer Sample Availability Date:	February 20, 2024		
Last date to request Samples by Customer :	March 30, 2024		
Please note if Samples are not requested as per Customer Samples Request date, it may take additional 4-6 weeks to arrange Samples.			
Traceability Code Markings / Date :	Lot information on label		

Before Picture

Overview

- This 350211360 is currently only manufactured in tool #2 of 35021160 but due to the overcapacity of tool #2, it can also be manufactured in tool #4 of 35021160 to expand the availability of production.
- To better serve our customers and stable delivery performance.
- Part Number Impact
 - Please refer attached impacted part list.

Category	Before change	After change
Manufacturing Status (350211360)	Use tool #2 of 35021160	Use tools #2 and #4 of 35021160
Product	Current	No change
4M	Current	No Change in Man, Material and Method Add Machine(Tool) for production

After Picture

After change

- **Product Impact**
 - There is no impact to fit, form or function by this change.
- Qualification Reports and samples available upon request after the date shown above.
- Implementation date may be updated due to customer demand and production condition.
- Drawing reference for comparing 350211160 and 350211360

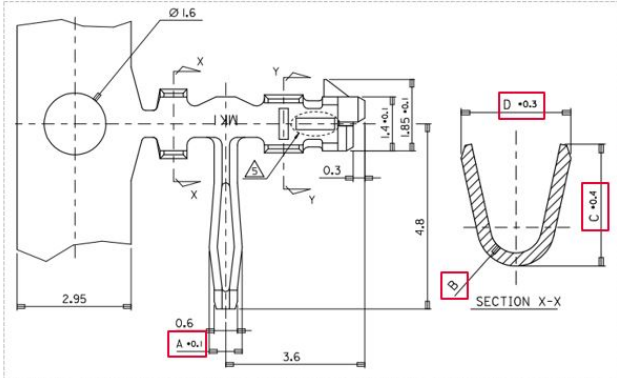

Part No.	Wire	A	B	C	D
350211160	#22-#28	1.05	R0.7	2.5	2.5
350211360	#24-#30	0.85	R0.4	1.9	1.8

RELEASED

You may address inquiries regarding this PCN by clicking on the below link
mailto:pcn_coordinator@molex.com?subject=PCN_Notification:514934
 or contact your Local Sales Engineer.

Note: While responding, please retain " PCN Notification : **PCN Notification: 514934** " in the e-mail Subject line for faster response.

Molex, LLC
 2222 Wellington Court
 Lisle, IL 60532
 TEL (800) 786-6539
www.molex.com