

CUSTOMER MCM FILE NO. 26-730

THIS DRAWING AND SPECIFICATIONS, HEREIN ARE THE CONFIDENTIAL PROPERTY OF SAMAR AND SHALL NOT BE REPRODUCED OR COPIED OR DISCLOSED IN WHOLE OR IN PART WITHOUT WRITTEN PERMISSION.

REV.	DESCRIPTION	DRAWN / DATE	APPROVED / DATE
0	INITIAL RELEASE	FROS 08/28/2013	FROS 08/28/2013

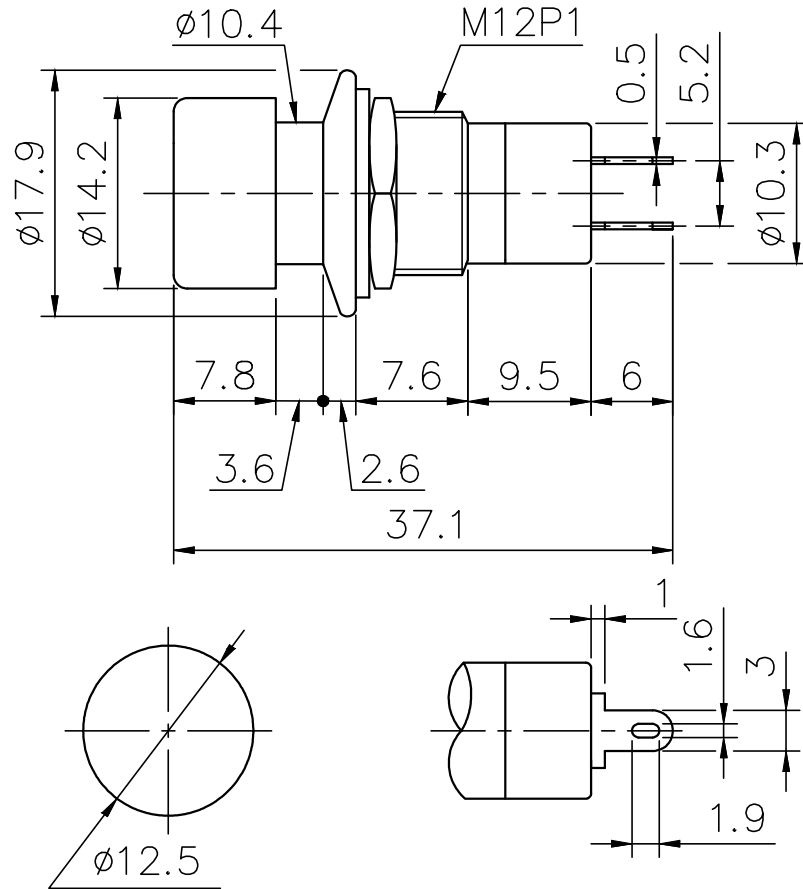

SPECIFICATION

- 1. Rating : AC 125V 3A Max.
- 2. Contact R. : 50mΩ Max.
- 3. Insulation R. : DC 500V 100MΩ Min.
- 4. Dielectric Strength : AC 1500V 1 minute.
- 5. Operating Temperature : -40℃ ~ +65℃
- 6. Electrical Life : 20,000 make-and-break cycles at full load.
- 7. Mechanical Life : 50,000 make-and-break cycles

Open and Close Type

Panel Thickness :  
2.5mm Max.

DIMENSIONS ARE IN mm [INCH]		TOLERANCES ARE FRACTIONS DECIMALS ANGLES		MATERIAL		P/N 26-730		DRAWN FROS		DATE 08/28/2013	
MOLD NO.		.x ± 0.20 [0.008]		FINISH		PROJECT NO.					
26-730		.xx ± 0.12 [0.005]		COLOR		SCALE N/A		SIZE A4		SHEET 1 OF 1	



PUSH BUTTON SWITCH  
RED

MY018